

# MODUL PRAKTIKUM PROGRAM STUDI DESAIN PRODUK

---



Universitas  
**Esa Unggul**

Universitas  
**Esa Unggul**

Universitas  
**Esa Unggul**



Universitas  
**Esa Unggul**



Universitas  
**Esa Unggul**



Universitas  
**Esa Unggul**



Universitas  
**Esa Unggul**



Universitas  
**Esa Unggul**



Universitas  
**Esa Unggul**



Universitas  
**Esa Unggul**



Universitas  
**Esa Unggul**



Universitas  
**Esa Unggul**



**Indra G Rochyat, S.Sn., M.Ds.**

Universitas  
**Esa Unggul**



Universitas  
**Esa Unggul**



Universitas  
**Esa Unggul**

	<b>DESAIN INDUSTRI 2</b>	<b>1</b>
	<b>PRAKTEK</b>	

### **PETUNJUK PELAKSANAAN BUKU MATERI**

Teori :

1. Perhatikan setiap hal yang dijelaskan / digambarkan oleh dosen.
2. Catat hal-hal yang dianggap perlu.
3. Jangan mempelajari modul berikutnya jika belum memahami benar pada modul sebelumnya.
4. Tanyakan selalu hal-hal yang belum jelas.
5. Evaluasi diri sendiri dengan mengerjakan soal-soal latihan yang ada pada modul teori.

Praktek :

1. Perhatikan setiap hal yang dijelaskan / digambarkan oleh dosen.
2. Catat hal-hal yang dianggap perlu.
3. Jangan mengerjakan latihan berikutnya jika belum memahami benar pada latihan sebelumnya.
4. Lakukan setiap proses penggambaran sesuai dengan urutan dan cara-cara yang benar.
5. Tanyakan selalu hal-hal yang belum jelas.
6. Berlatih selalu dengan tekun dan disiplin

# **HOWS INDUSTRIAL DESIGN WORKS 2**

## **1. PENENTUAN AREA PRODUK**

Adalah dimana mahasiswa harus menentukan secara garis besar tentang tema yang sedang berkembang di masyarakat untuk dijadikan acuan dasar didalam mengembangkan kebutuhan pasar

Kebutuhan pasar yang di maksud adalah dengan mengembangkan tema besar yang ada di tengah-tengah masyarakat

## **2. PENENTUAN PEMINATAN**

Mahasiswa diharapkan dapat mengetahui potensi yang ada pada diri masing masing individu, sehingga dapat secara jelas penempatan akan peminatannya di dalam mengembangkan desain.

Penentuan peminatan akan dikembangkan berdasarakan tema yang telah dipersempit menjadi produk andalan industry yang akan dicarikan permasalahan

## **3. PENENTUAN KELOMPOK ATAU INDIVIDU**

Mahasiswa dihadapkan pada tugas-tugas kuliah yang berorientasi pada nilai kelompok dan individu, hal tersebut dikarenakan proses kreatif yang selalu dinamis.

Penentuan kelompok atau individu akan ditentukan oleh dosen pangampu matakuliah dan akan disesuaikan dengan kebutuhan dan ketertarikan mahasiswa dengan produk industri

ALAT :

1. Pencil Jenis Hard (H) untuk membuat garis konstruksi
2. Media kertas gambar Padalarang dan sejenisnya
3. Bukugambar
4. Peralatan survey yang diperlukanolehmahasiswa



	<b>DESAIN INDUSTRI 2</b>	<b>2</b>
	<b>PRAKTEK</b>	

P2 DESAIN INDUSTRI- PRAKTIKUM dan SURVEY LAPANGAN

*If your product could do anything, what would you want it to do? OBSERVING is the answer*

**OBSERVATION**

- **SHADOWING**

*Collecting data and fact about all environment that surrounding the product and user the product*

Mencari data berdasarkan yang ditemukan dilapangan yang berkaitan antara produk industry tersebut dengan pengguna produk dan lingkungannya

- **BEHAVIORAL MAPPING**

Memetakan masalah berdasarkan kebiasaan pengguna dalam menggunakan produk industry

*Problem:*

*In any man-made environment, discrepancies may exist between the intent of its design and how it is actually used.*

*Solution:*

*Behavioral Mapping allows researchers to determine how participants use a designed space by recording participant behaviors and/or tracking participant movement within the space itself.*

*Use when:*

*Behavioral mapping can be useful to help identify underlying patterns of participant movement and behavior within a given environment.*

*Use for:*

*Planning improvements to an existing space, improving the overall design of similar spaces in the future or confirming that a newly designed or redesigned space supports the behaviors for which it was designed.*

Process:

*This methodology is unobtrusive (done “at a distance”) and often undertaken in public areas, so participant consent may not be required.*

*The process for “person-centred” behavioural mapping is outlined below.*

- 1) **Materials** – *Begin with a site plan or map—typically, a top-down-style drawing of the area under study, sketched on paper or created with a graphics software application. Produce multiple photocopies or prints of the map as necessary. (A single sheet can capture both motions and behaviours, visually aggregating the data in the process; however, this may prove more difficult to read than tracking individual participants on separate sheets.)*





2) **Parameters** – List the behaviours that will be recorded during the study. This crucial step helps researchers to avoid making assumptions about the behaviours they might encounter during the study. It also helps them avoid the temptation to record every observed behaviour rather than those deemed most relevant to the research question.

Develop a method of notation for locating recorded behaviours on the map, such as initials, symbols or colour-coded dots. Depending on the needs of the study, researchers may also wish to capture basic demographic data on each participant. Some studies may benefit from recording each participant's movement through the space (usually indicated as a line on the map). However, researchers may also wish to record the various directions that a participant faced, or note the places where a participant stopped moving.

Time is often an important data point in behavioural mapping studies, as well. How long was each stop? For how long was each behaviour displayed? How long was the overall stay or journey of each participant? Define the duration of observing a specific participant. This decision can be based on various conditions: after a set amount of time, when the participant leaves the area, when the researcher loses sight of the participant, or any combination of factors.

3) **Record** – Each researcher records the behaviour of a single participant respectively, making notations on the map until one of the conditions for ceasing observation is met. At this point, the researcher becomes available to observe the next participant who arrives. (Note: researchers should avoid overlapping their observations—in other words, no two researchers should track the same individual.)

4) **Analysis** – Viewing the results in aggregate is often a useful first step. For example, visually overlaying the paths that participants took may help to determine heavy traffic zones versus underused areas. (Recall that behavioural mapping is typically combined with other qualitative methods in an effort to uncover participant motivations.)

**Note:** Various factors—including the time of day, the day of the week, the season, weather conditions, special events and calendar holidays—may have a dramatic impact on the number of participants observed and the types of behaviours displayed. To reduce or otherwise account for these uncontrollable variables, multiple visits to the site, perhaps even

over the course of a full year, may be required to accurately capture a site's usage patterns.

- **CONSUMER JOURNEY**

Article | *McKinsey Quarterly*

*The consumer decision journey*

*Consumers are moving outside the purchasing funnel—changing the way they research and buy your products. If your marketing hasn't changed in response, it should.*

June 2009 | by David Court, Dave Elzinga, Susan Mulder, and Ole Jørgen Vetvik

The consumer decision journey—an interactive

Consumers are changing the way they research and buy products..

- **CAMERA JOURNALS**

- **EXTREME USER INTERVIEWS**

- **STORYTELLING UNFOCUS GROUPS**

OBSERVATION ITEMS

*Think future context*

Creating science fact not science fiction

*Technical opportunity*

Satisfied users. Surprising features. Value in innovation

*Brand attitudes*

Building identity on knowledge



	<b>DESAIN INDUSTRI 2</b>	<b>3</b>
	<b>PRAKTEK</b>	

**P3 DESAIN INDUSTRI– PRAKTIKUM**

**DESIGN BRIEF**

**Memahami apa yang akan dituju dalam menghasilkan sebuah produk industri yang baru**

*A **design brief** is a written document for a design project developed in concert by a person representing the business need for design and the designer. The document is focused on the desired results of design – not aesthetics. Design briefs are commonly used in consulting engagements, when an independent designer or a design agency executes a design on behalf of a client. They are less common when the designer is in-house.*

**USER INVESTIGATION**

<h2>Analysis of Design Brief</h2>	
Key Features to be Considered	Commentary
<b>Function</b> Where will the product be used? What will my product be used for?	My product will be used to hold trophies medals and other valuables. My final idea is intended to be used at home only as it is where you want to keep your valuables.
<b>Performance</b> How might the product be used?	The final design can be used anywhere in the household but more to the point it will have to be on a desk as it is not going to be big enough to place on the floor.
<b>Purpose Market</b> Who might use the product? Is there other competition with a similar product? What types of people are most likely to buy my product?	I am aiming my product at people above the age of 14. This is because most people start to win trophies and medal at the ages of 14 onwards. There is no other known competition. People that are playing sports and winning medals or winning anything one way or another are most likely to be buying my product.
<b>Quantity</b> How many will be needed?	I will be making one trophy cabinet out of a batch of 50.
<b>Style</b> What will the product look like? Will the product appeal to the target market?	The product has a square curved base with small stands at the base which will keep the cabinet balanced and standing. There are drawers at the bottom to keep certificate and also any other types of thing that can go into a portfolio. Yes the futuristically design and appeal ability will help to make the product sell very well
<b>Quality</b> What level of quality will be used to make my product? Does the client have special requirements? Are their national standards to be met?	I will make my product to the highest quality possible. The client requires lots of storage space and enough space to hold around 20 trophies and medals. The national standards are that the product doesn't break during the use or damage anyone's property.
<b>Cost</b> What will each item cost to produce? What level of profit is needed? What is the final cost likely to be?	Each item will cost around £10.99 to make and will be sold at £24.99. I hope to achieve around a £15 profit from selling each individual unit. The final cost, dependant on if the product sells well will be upped to £24.99 to make more profit
<b>Timescale</b> When does the client wish the project to be finished? When should the product be ready for the same?	The client wishes the project to be made on a 40 hour timescale. I am hoping to finish the product within the set time although final modifications could alter the time needed to make the final design.

# Design Brief

- Write down how you will attempt to address the new Problem statement.
- What information are you going to need to gather? Where will it come from? What skills are you going to have to learn? How are you going to learn them?
- How, where, when will you create your solution and how will you know that it works?
- Look for examples of similar products so that you can identify necessary and desirable characteristics. Include pictures of these so that they are easy to refer to and you, and your audience, can see what you are talking about.

**Membuat pernyataan permasalahan dari produk yang akan dibuat**



	DESAIN INDUSTRI 2	4
	PRAKTEK	

*P4 DESAIN INDUSTRI – PRAKTIKUM*

**FROM ART TO PART**

**Membuatrangkaiansketsauntukdijadikansebuah model  
ataupercontohandalampemebtukangagasanatau ide**

*DISIGNING AND CONCEPT*

- *PROBLEM STATEMENT*  
**Pernyataanmasalahdalamproduk industry**

- *BRAINSTORMING IDEAS*  
**Membuatbeberapa alternative pendekatan ide dankonsep**

**A. PROBLEM STATEMENT**

*“Begins from the problem statement”*

*“The design brief should be clear and simple”*

***The designer attempts to produce an outline of a solution***

*A conceptual design is a usually an outline of key components and their arrangement with the details of the design.*

*You may find that you like several of the solutions. Eventually, you must choose one. Careful comparison with the original design brief will help you to select the best. Deciding among the several possible solutions is not always easy. Then it helps to summarize the design requirements and solutions and put the summary in a chart. Which would you choose? In case like this, let it bethe one you like the best*

**B. BRAINSTORMING IDEAS**

*Brainstorming is one of the most common types of informal idea invention. Brainstorming comes in handy in many situations where creative, cognitive thinking is required. Whether you're coming up with an idea for a new product for your business or you want to come up with a concept for your next oil painting, this wikiHow article can help you get those creative juices flowing.*

*Creating Your Road Map  
Getting Inspiration  
Brainstorming Techniques*

**1. Creating Your Road Map**

**A. Look at your goal.**

*Before you look at what you want to do, think about what you're trying to achieve. This can give you a good starting point, a sort of light at the end of the tunnel.*

- *Do you want to brainstorm for your business?*
- *Are you trying to come up with an idea for your next work of art?*
- *Maybe you're trying to come up with an idea for an article you have to write?*

**B. Understand any requirements.**

*If you have a teacher, boss, client, or someone that will be evaluating your work, find out what they're expecting or what they need. If not, just think about the limitations you must work within and what the final product should accomplish. While breaking requirements can sometimes result in a better experience and final product, knowing all of the limitations will give you a good framework to start working in.*

*For example, do you need to keep to a certain budget?*

*Do you need to use only certain materials?*

*Does the project need to be done by a certain time?*

**C. List out and evaluate your assumptions.**

*You'll naturally be assuming some things about your project. What are people looking for? What are your limitations? What is acceptable or normal? What should it generally look like? List these assumptions so that you can play on them later.*

- *For example, with an art project, we might assume that people are looking for a particular color scheme that fits with the theme of a gallery show.*
- *For a business project, we might assume that customers are wanting a particular something that our competitor's product does not provide.*

**D. Evaluate what you have to work with.**

*Take a hard look at what you've done in the past, what you've done already, and what you have available to you in terms of resources. This will help give you some boundaries to work with.*

- *What kind of tools do you have to use?*
- *What materials or people have you not made use of in a long time?*
- *What was something you tried last year and how could it be better?*
- *Ask others for their opinions.*



## 2. Getting Inspiration

### A. Do some research.

*Do some research on what people working on similar projects have been doing. Google is your friend in this adventure. You should not be looking at what others are doing in order to copy them. Instead, you should be seeing where their ideas fall short or what pieces of their project might fit into yours.*

### B. Look at what the innovators are doing.

*Once you see what run-of-the-mill folks are doing, find out what the innovators are doing. Seek out the cutting edge and fringe ideas or techniques that other people are experimenting with. You might want to similarly experiment! Such innovation can set you apart, making what you do unique, memorable, and appealing.*

### C. Go somewhere.

*Get outside of your usual environment. This is a great way to break yourself out of the standard creation loop and think of things that you've never thought of before. Go for a walk, go to a local artisan or farmer's market, or work in a cafe for awhile. Any change of environment can help you think in different ways.*

### D. Keep a journal next to your bed.

*Always have a journal next to your bed. You'll also want to keep a waterproof note-taking option in your shower area. Good ideas often sneak up on us when we're doing these other activities, but then get lost as we get distracted with whatever else it is we're doing. By having a pen and paper nearby, you'll be able to quickly jot down the things you think of before they fly away!*

### E. Take breaks!

*It's important to take breaks, to keep your mind clear of negative response loops. A lot of the time, when you're thinking and coming up with nothing, you get too focused on the fact that you're coming up with nothing, making it impossible to really think. Try having a healthy snack, catch up with a coworker, or do a quick chore (such as cleaning up your mess from dinner).*

### F. Shut out criticism.

*During the brainstorming process, criticism isn't helpful. You'll need the freedom of minimal boundaries in order to get to new ideas. Leave criticism for once you have a long list of possibilities.*



	<b>DESAIN INDUSTRI 2</b>	<b>5</b>
	<b>PRAKTEK</b>	

P6 DESAIN INDUSTRI – PRAKTIKUM

## Brainstorming Techniques

**A. Warm up.**

Don't try to brainstorm with just a cold start. This is like breaking out into a full run without a light jog first! Do a quick exercise that gets your head in that space, such as making a menu for your next week's worth of dinners, or coming up with a wish list of things you'd like to accomplish in work, school, or whatever it is you're doing.

If you're brainstorming with other people, you might need to remind some people to keep negative opinions to themselves until the brainstorming activity is done.

**B. Change your perspective.**

Put yourself in the shoes of your competitor, looking at what you're doing now and trying to figure out how to be better than you. How would they look at what you're doing and do things better? What would they change? Where would they go next?

**C. Introduce roadblocks.**

Giving yourself new roadblocks to reaching your goal, such as a lower budget, a new deadline, or a specific material to be used, can make you more creative and innovative. It may even give you an idea if you couldn't come up with one before.

**D. Make a mind map.**

Mind maps are one of the most popular brainstorming techniques. This is where you write down an idea (or several!) on a notecard. Pin the note card to a wall and then build on the idea. Write down every little thing you think of and start connecting the ideas.

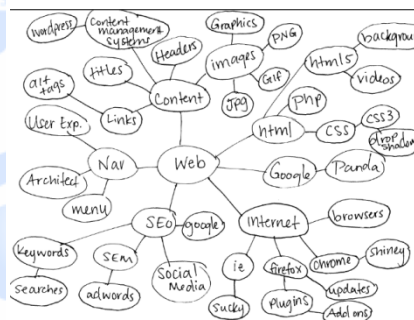

**E. Create idea categories.**

Create three categories: easy ideas, tough ideas, and crazy ideas. Try to come up with at least five ideas for each category. Usually, in coming up with ideas we think we can't or shouldn't actually carry out, we find ourselves with ideas that we actually can use.

**F. Write a poem, analysis, or review.**

Write a poem that describes what you're trying to do. You can also write a theoretical analysis or review of the thing you're hoping to create. By outlining what you're wanting to get out of the project, you may have an easier time thinking of ways to do it.

**G. Bring an old technique into the new age.**

Take something you've done before, a long time ago, and find a way to update it. You can also take old concepts that aren't yours and find a way to bring them into this era. For example, Twitter was basically telegrams for the internet. Some of the most popular products right now make use of classic designs.

**H. Use an online idea generator.**

Online idea generators can be really helpful in getting you started, even if it's just used as a warm up. Don't feel burdened by or tied to the ideas that it gives you, but try to use them as a jumping off point.

**I. Keep asking questions.**

Always ask questions. Ask questions of yourself. Ask questions of the people you're brainstorming with. Ask questions of your friends and family members. Questions lead us to really think through things that we might have glazed over in our minds. Ask detailed questions and questions that really get at the heart of the issue. And don't go for the short, obvious answer.

*Why do I want to paint with oils?*

*Why does my customer want this product?*

**J. Don't waste time.**

There are lots of little exercises, like mind maps, that can be really useful. But a lot of the time they're also a distraction and can hold you back from really getting work done. Don't waste too much time on brainstorming activities, and instead try to just get down to business as quickly as possible.

**K. Do some free-writing.**

Free writing is where you start writing and you just don't stop. This also involves some free association, where you naturally follow the course that your thoughts take instead of trying to direct the current. Just write down a sentence that deals with the topic you're trying to brainstorm on and then follow your brain, writing down every word that ambles through your internal dialogue without stopping to think. You never know where it will lead you!



Universitas  
Esa Unggul



Universitas  
Esa Unggul



Universitas  
Esa Unggul



Universitas  
Esa Unggul



Universitas  
Esa Unggul

Esa Unggul

Esa Unggul

Esa Unggul

	DESAIN INDUSTRI 2	6
	PRAKTEK	

P6 DESAIN INDUSTRI – PRAKTIKUM

**FROM ART TO PART**

*DISIGNING AND CONCEPT*

*QUANTIFIED STRUCTURE*

*It is important when designing a product that you not only consider the product design specification but you also consider the activities downstream of the design stages*

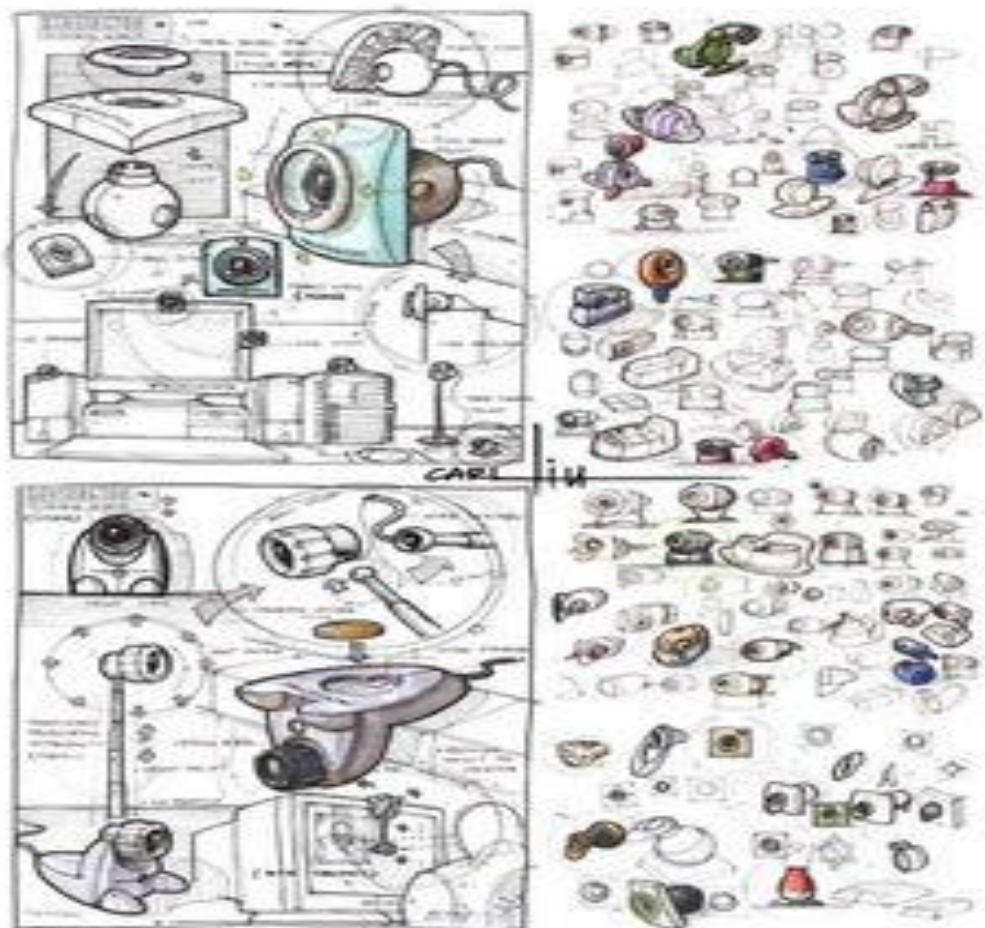

PICTURE 1  
QUANTIFIED MODEL



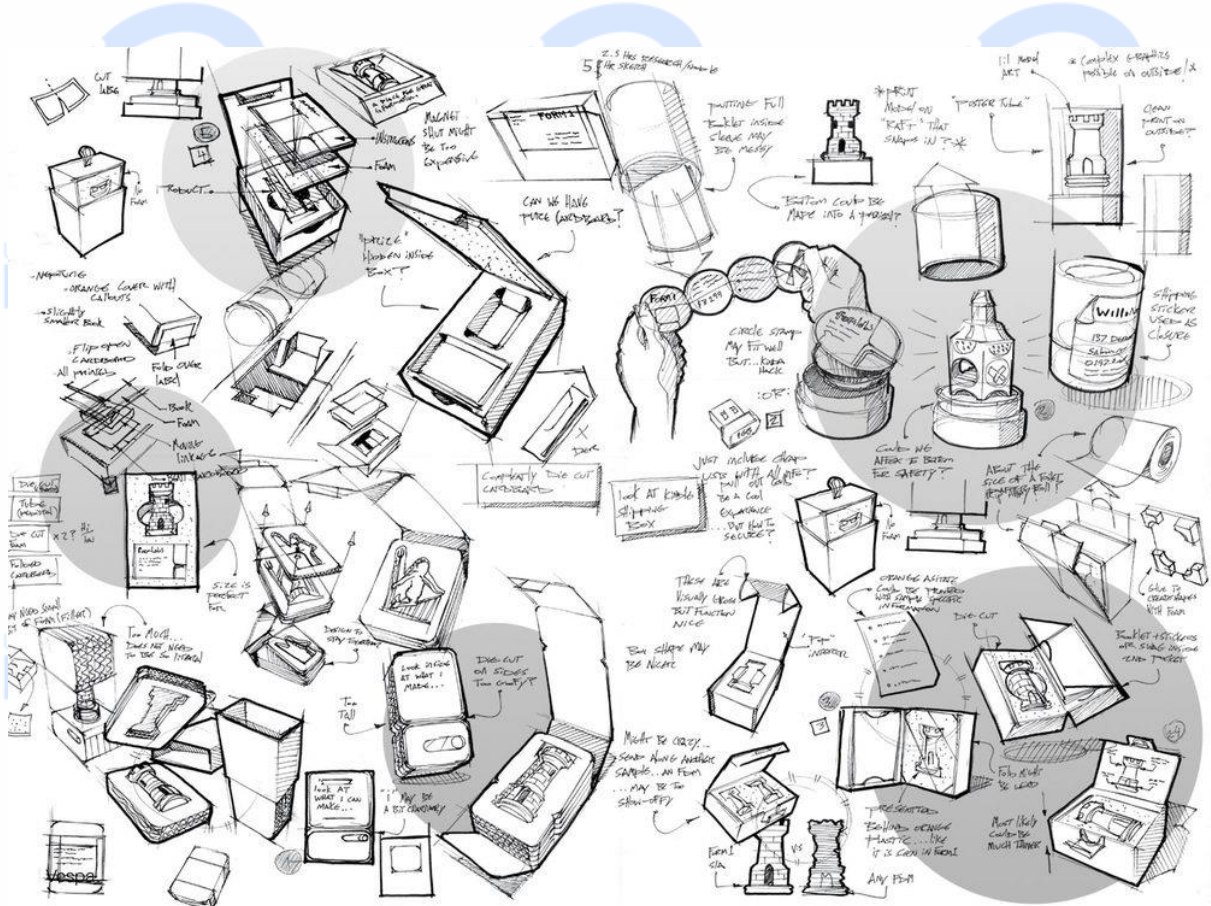

**PICTURE 2**  
**QUANTIFIED STRUCTURE**

MAHASISWA MENGGAMBAR SKETSA DENGAN CEPAT DAN TEPAT

	DESAIN INDUSTRI 2	7
	PRAKTEK	

## P7 DESAIN PRODUK - PRAKTIKUM

### **FROM ART TO PART**

#### **REFINEMENT DESIGN**

*As a tool or skill, sketching has its role in the design process. That role will vary depending on the end-product being created, the size and scope of the project, the individual designer's style, experience, and workflow, and the client's expectations. Find out more about how sketching is used in the design process within multiple design disciplines. The role of sketching in digital art varies depending on if your creating Web sites, identities, illustrations, product concepts, or other designs. An illustration or a logo is likely to need more sketching than a website.*

*A large project with a significant client budget will benefit from sketching throughout the design process. This makes sure that before massive amounts of time are invested on refining a solution, a direction is first agreed upon with the client. Sketching can start loose, beginning with basic concepts. Then work on compositions or layouts. After those directions are chosen, the concepts can further be refined with detailed sketching.*

#### **5 Uses for Sketching in Design**

*There are multiple uses for sketching in the design process. Below is a review of five categories of uses with examples and links.*

##### **Rapid Concept Development**

*Sketching is an excellent way to quickly explore concepts. You can sketch for one or two hours and work out multiple possible solutions to the design problem at hand. This is an essential step in the design process. It will save you time to work through concepts on paper before going to the computer.*



## P8 DESAIN INDUSTRI – PRAKTIKUM

### **PACKAGING - KEMASAN**

#### **A. SEJARAH SINGKAT KEMASAN**

Selama berabad-abad, fungsi sebuah kemasan hanyalah sebatas untuk melindungi barang atau mempermudah barang untuk dibawa. Seiring dengan perkembangan jaman yang semakin kompleks, barulah terjadi penambahan nilai-nilai fungsional dan peranan kemasan dalam pemasaran mulai diakui sebagai satu kekuatan utama dalam persaingan pasar. Menjelang abad pertengahan, bahan-bahan kemasan terbuat dari kulit, kain, kayu, batu, keramik dan kaca. Tetapi pada jaman itu, kemasan masih terkesan seadanya dan lebih berfungsi untuk melindungi barang terhadap pengaruh cuaca atau proses alam lainnya yang dapat merusak barang. Selain itu, kemasan juga berfungsi sebagai wadah agar barang mudah dibawa selama dalam perjalanan. Baru pada tahun 1980-an di manapersaingan dalam dunia usaha semakin tajam dan kalangan produsen saling berlomba untuk merebut perhatian calon konsumen, bentuk dan model kemasan dirasakan sangat penting peranannya dalam strategi pemasaran. Di sini kemasan harus mampu menarik perhatian, menggambarkan keistimewaan produk, dan “membujuk” konsumen. Pada saat inilah kemasan mengambil alih tugas penjualan pada saat jual beli terjadi.

#### **TUGAS PRAKTIKUM**

1. Membuat kemasan sederhana dari bahan dan material yang telah disediakan
2. Mahasiswa membawa alat perekat dan alat pemotong yang disesuaikan dengan materialnya
3. Mahasiswa memperhatikan arah dan arah di atas dan di bawah dalam melakukan langkah-langkah pengerjaan

	<b>DESAIN INDUSTRI 2</b>	<b>9</b>
---	--------------------------	----------

## P9 DESAIN INDUSTRI – PRAKTIKUM

### **PACKAGING – contoh produk industri : desain KEMASAN**

#### **PENGERTIAN DAN RUANG LINGKUP KEMASAN**

Kemasan dapat didefinisikan sebagai seluruh kegiatan merancang dan memproduksi wadah atau bungkus atau kemasan suatu produk. Kemasan juga dapat diartikan sebagai wadah atau pembungkus yang guna mencegah atau mengurangi terjadinya kerusakan-kerusakan pada bahan yang dikemas atau yang dibungkusnya. Kemasan meliputi tiga hal, yaitu merek, kemasan itu sendiri dan label. Ada tiga alasan utama untuk melakukan pembungkusan, yaitu:

1. Kemasan memenuhi syarat keamanan dan kemanfaatan. Kemasan melindungi produk dalam perjalanannya dari produsen ke konsumen. Produk-produk yang dikemas biasanya lebih bersih, menarik dan tahan terhadap kerusakan yang disebabkan oleh cuaca.
2. Kemasan dapat melaksanakan program pemasaran. Melalui kemasan identifikasi produk menjadi lebih efektif dan dengan sendirinya mencegah pertukaran oleh produk pesaing. Kemasan merupakan satu-satunya cara perusahaan membedakan produknya.
3. Kemasan merupakan suatu cara untuk meningkatkan laba perusahaan. Oleh karena itu perusahaan harus membuat kemasan semenarik mungkin. Dengan kemasan yang sangat menarik diharapkan dapat memikat dan menarik perhatian konsumen. Ruang lingkup bidang kemasan saat ini juga sudah semakin luas, mulai dari bahan yang sangat bervariasi hingga bentuk dan teknologi kemasan yang semakin menarik. Bahan kemasan yang digunakan bervariasi dari bahan kertas, plastik, kayu, logam, fiber hingga bahan-bahan yang dilaminasi. Bentuk dan teknologi kemasan juga bervariasi dari kemasan berbentuk kubus, limas, tetrapak, corrugated box, kemasan tabung hingga kemasan aktif dan pintar (active and intelligent packaging) yang dapat menyesuaikan kondisi lingkungan di dalam kemasan dengan kebutuhan produk yang dikemas. Produk dalam kantong plastik, dibalut dengan daun pisang, sekarang juga sudah berkembang sampai dalam bentuk botol dan kemasan yang cantik.

#### **TUGAS PRAKTIKUM (lanjutan)**

1. Membuat kemasan sederhana dari bahan dan material yang telah disediakan
2. Mahasiswa membawa alat perekat dan alat pemotong yang disesuaikan dengan materialnya

DESAIN PRODUK

**FINISHING PROJECT FROM ART TO PART**  
**Model scale making**

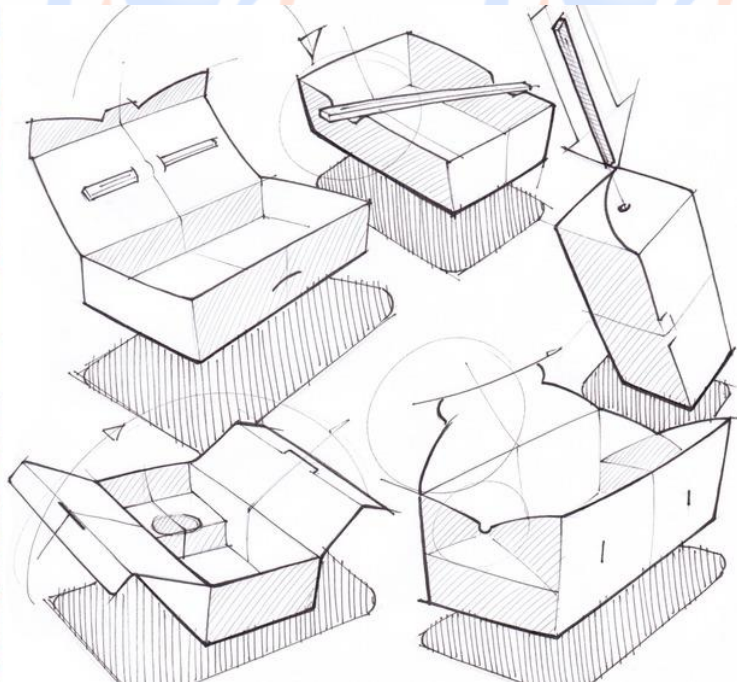

TUGAS PRAKTIKUM

1. Membuat kemasan sederhana dari bahan dan material yang telah disediakan
2. Mahasiswa membawa alat perekat dan alat pemotong yang disesuaikan dengan materialnya
3. Mahasiswa memperhatikan arahan dari dosen dalam melakukan langkah-langkah pengerjaan.

## **FINISHING PROJECT FROM ART TO PART**

### **Model scale making PACKAGING**



#### TUGAS PRAKTIKUM

1. Membuat kemasan sederhana dari bahan dan material yang telah disediakan
2. Mahasiswa membawa alat perekat dan alat pemotong yang disesuaikan dengan materialnya
3. Mahasiswa memperhatikan arahan dari dosen dalam melakukan langkah-langkah pengerjaan



## **FINISHING PROJECT FROM ART TO PART** MEMBUAT SKALA

Skala adalah angka yang menunjukkan perbandingan jarak di peta dengan jarak sebenarnya.

Sedangkan Peta adalah gambaran permukaan bumi pada bidang datar dengan skala tertentu melalui suatu system proyeksi.



### TUGAS PRAKTIKUM

1. Membuat kemasan sederhana dari bahan dan material yang telah disediakan
2. Mahasiswa membawa alat perekat dan alat pemotong yang disesuaikan dengan materialnya
3. Mahasiswa memperhatikan arahan dari dosen dalam melakukan langkah-langkah pengerjaan.



## **FINISHING PROJECT FROM ART TO PART**

### MEMBUAT SKALA

#### **Rumusdasar**

$$P \text{ Benda} / P \text{ Bayangan} = L \text{ Benda} / L \text{ Bayangan}$$

$$P \text{ Benda} / L \text{ Benda} = P \text{ Bayangan} / L \text{ Bayangan}$$

\*P = Panjang

\*L = Lebar

Rumus tersebut adalah gambaran dasar tentang model, rumus tersebut tidak boleh terbalik seperti

$$P \text{ Benda} / P \text{ Bayangan} = L \text{ Bayangan} / L \text{ Benda}$$

$$P \text{ Benda} / L \text{ Benda} = L \text{ Bayangan} / P \text{ Bayangan}$$

Nah jadi hati-hati ya dalam mengerjakannya Oiya, itu tidak harus bayangan bias jadi miniature dsb.

#### **Contoh soal**

Sebuah benda mempunyai panjang 50m dan lebar 20 m. Mempunyai bayangan dengan panjang 10 cm. Berapakah lebar bayangan benda tersebut?

(Kita tidak usah mengubah dari m ke cm, karena hasilnya sama saja)

Diketahui

$$P \text{ benda} / L \text{ benda} = P \text{ bayangan} / L \text{ bayangan}$$

$$50 \text{ m} / 20 \text{ m} = 10 \text{ cm} / L \text{ bayangan}$$

$$L \text{ bayangan} = 20 \text{ m} \times 10 \text{ cm} / 50 \text{ m} = 4 \text{ cm}$$

Cara diatas memakai perkalian silang



GAMBAR MODEL BERSKALA



## FINISHING PROJECT FROM ART TO PART 3D MODELING AND PRESENTATION



Pemodelan **3 Dimensi** adalah prosedur pengembangan **model 3 Dimensi** menggunakan perangkat lunak khusus. Prosedur ini dilakukan sebagai proses untuk menciptakan sebuah **model** yang mewakili objek sebenarnya secara tiga **dimensi**.

**Pemodelan 3 Dimensi** adalah prosedur pengembangan model 3 Dimensi menggunakan perangkat lunak khusus. Prosedur ini dilakukan sebagai proses untuk menciptakan sebuah model yang mewakili objek sebenarnya secara tiga dimensi. Objek yang dibuatkan modelnya bias berupa objek hidup ataupun benda mati. Sebuah model tiga dimensi dibuat dengan menggunakan sejumlah titik dalam ruang 3D, yang dihubungkan dengan berbagai data geometris seperti garis, bidang datar, dan permukaan melengkung yang menghasilkan bentuk 3 Dimensi utuh menyerupai objek yang dijadikan model.

## DaftarPustaka

1. Lawson, Bryan. 1990. *How Designers Think*. Butterworth Architecture.
2. Pena, Parshall. 2006. *Problem Seeking–Fourth Edition*. HOK. Pub.
3. Roozenburg, N.F.M. & J. Eekels. 1995. *Product Design: Fundamentals and Methods*. John Wiley & Sons.

