

KUESIONER PENELITIAN**A. Karakteristik Responden**

Berikan tanda centang (\surd) atau silang (X) pada satu pilihan yang sesuai dengan jawaban anda.

1. Jenis kelamin

<input type="checkbox"/> Laki-laki	<input type="checkbox"/> Perempuan
------------------------------------	------------------------------------
2. Usia

<input type="checkbox"/> \leq 20 tahun	<input type="checkbox"/> 31 – 40 tahun
<input type="checkbox"/> 21 – 30 tahun	<input type="checkbox"/> $>$ 40 tahun
3. Pendidikan formal terakhir

<input type="checkbox"/> SD / sederajat	<input type="checkbox"/> SMA / sederajat	<input type="checkbox"/> S1	<input type="checkbox"/> S3
<input type="checkbox"/> SMP / sederajat	<input type="checkbox"/> D3	<input type="checkbox"/> S2	
4. Pekerjaan

<input type="checkbox"/> Pelajar / mahasiswa	<input type="checkbox"/> Ibu rumah tangga
<input type="checkbox"/> Pegawai swasta	<input type="checkbox"/> Tidak / belum bekerja
<input type="checkbox"/> PNS/TNI/POLRI	<input type="checkbox"/> Lainnya
<input type="checkbox"/> Profesional	
5. Tempat yang dikunjungi:

Poli Anak Poli Obsgyn
6. Jumlah Kunjungan

<input type="checkbox"/> \geq 1 kali	<input type="checkbox"/> $>$ 3 kali
--	-------------------------------------

B. Pernyataan

Berikan tanda centang (\surd) atau silang (X) pada satu pilihan yang sesuai dengan keseluruhan penilaian anda pada saat dan setelah anda menggunakan jasaRSIA Brawijaya Jakarta.

Keterangan:

STS : Sangat Tidak Setuju S : Setuju
TS : Tidak Setuju SS : Sangat Setuju
N : Netral

No	Pertanyaan	STS	TS	N	S	SS
1.	RSIA Brawijaya memberikan layanan yang tepat sejak awal					
2.	RSIA Brawijaya memberikan layanan sesuai dengan yang dijanjikan					
3.	RSIA Brawijaya mampu melayani keluhan pasien					
4.	RSIA Brawijaya menjamin tidak terjadi kesalahan dalam pencatatan					
5	Petugas selalu memberikan informasi kapan layanan akan diberikan					
6	Pasien mendapatkan pelayanan yang cepat di RSIA Brawijaya					
7	Petugas selalu bersedia untuk membantu pasien					
8	Petugas selalu tanggap terhadap kebutuhan pasien					
9	Petugas mampu memberikan keyakinan kepada pasien					
10	RSIA Brawijaya memberikan rasa aman dalam pelayanannya					
11	Petugas selalu bersikap sopan					
12	Petugas memiliki pengetahuan yang cukup untuk menjawab pertanyaan pasien					

No	Pertanyaan	STS	TS	N	S	SS
13	RSIA Brawijaya memberikan perhatian secara khusus kepada setiap pasien					
14	Petugas peduli terhadap keinginan pasien.					
15	RSIA Brawijaya mengutamakan kepentingan pasien.					
16	Petugas memahami kebutuhan pasien.					
17	RSIA Brawijaya menyediakan pelayanan 24 jam					
18	RSIA Brawijaya memiliki peralatan medis yang up to date					
19	Ruang tunggu dan tampilan gedung RSIA Brawijaya tampak megah					
20	Karyawan RSIA Brawijaya berpenampilan rapi					
21	Lingkungan di RSIA Brawijaya nyaman					
22	Tarif yang ditetapkan di RSIA Brawijaya masih dalam kewajaran					
23	Harga pemeriksaan yang ditetapkan di RSIA Brawijaya sesuai dengan kualitasnya.					
24	Saya selalu memiliki kesan yang baik tentang RSIA Brawijaya					
25	Menurut pendapat saya, RSIA Brawijaya memiliki citra yang baik di benak pasien					
26	RSIA Brawijaya memiliki citra yang baik dibandingkan dengan rumah sakit lain					
27	Saya senang dengan keputusan saya memilih RSIA Brawijaya sebagai rumah sakit langganan saya					

No	Pertanyaan	STS	TS	N	S	SS
28	Saya yakin bahwa saya telah melakukan hal yang benar ketika memilih RSIA Brawijaya sebagai rumah sakit pilihan saya					
29	Secara keseluruhan saya puas dengan pelayanan di RSIA Brawijaya					
30	Saya tidak akan pindah ke rumah sakit lain, karena menurut saya kualitas RSIA Brawijaya baik.					
31	Saya akan selalu datang ke RSIA Brawijaya bila saya memerlukan pelayanan kesehatan					
32	Saya akan selalu menyarankan RSIA Brawijaya kepada semua orang yang meminta saran saya mengenai rumah sakit yang bisa diandalkan					

“Terima kasih atas partisipasi dan perhatian Anda dalam pengisian kuesioner ini. Semoga sukses dalam segala aktivitas.”

Lampiran 2
Frekuensi Demografi

No	Karakteristik Demografi	Kategori	Frekuensi (orang)
1	Jenis Kelamin	1.1 Laki-laki	33
		1.2 Perempuan	127
2	Usia	2.1 ≤ 20	24
		2.2 21-30	68
		2.3 31-40	50
		2.4 > 40	18
3	Pendidikan Formal Terakhir	3.1 SD	0
		3.2 SMP	0
		3.3 SMA	1
		3.4 D3	1
		3.5 S1	130
		3.6 S2	17
		3.7 S3	11
4	Pekerjaan	4.1 Pelajar/Mahasiswa	8
		4.2 P.Swasta	80
		4.3 PNS/TNI/POLRI	14
		4.4 Profesional	35
		4.5 IRT	23
		4.6 Belum Bekerja	0
		4.7 Lainnya	0
5	Tempat Berobat	5.1 Poli Obsgyn	65
		5.2 Poli Anak	95
6	Kunjungan	6.1 ≥ 1 Kali	45
		6.2 > 3 Kali	115

LAMPIRAN 3

Output SPSS ver 22, Validity dan Reliability Test pada Pretest

Reliability/ Keandalan

Factor Analysis**Correlation Matrix^a**

	SQ1	SQ2	SQ3	SQ4	SQ5
Correlation					
SQ1	1.000	.157	.510	.386	.106
SQ2	.157	1.000	.481	.258	.222
SQ3	.510	.481	1.000	.656	.276
SQ4	.386	.258	.656	1.000	.295
SQ5	.106	.222	.276	.295	1.000
Sig. (1-tailed)					
SQ1		.204	.002	.018	.289
SQ2	.204		.004	.084	.119
SQ3	.002	.004		.000	.070
SQ4	.018	.084	.000		.057
SQ5	.289	.119	.070	.057	

a. Determinant = .280

KMO and Bartlett's Test

Kaiser-Meyer-Olkin Measure of Sampling Adequacy.		.670
Bartlett's Test of Sphericity	Approx. Chi-Square	33.756
	df	10
	Sig.	.000

Anti-image Matrices

		SQ1	SQ2	SQ3	SQ4	SQ5
Anti-image	SQ1	.725	.077	-.204	-.047	.034
Covariance	SQ2	.077	.743	-.230	.062	-.094
	SQ3	-.204	-.230	.397	-.248	-.038
	SQ4	-.047	.062	-.248	.547	-.119
	SQ5	.034	-.094	-.038	-.119	.886
Anti-image	SQ1	.731 ^a	.105	-.381	-.075	.042
Correlation	SQ2	.105	.635 ^a	-.424	.097	-.116
	SQ3	-.381	-.424	.619 ^a	-.533	-.064
	SQ4	-.075	.097	-.533	.690 ^a	-.171
	SQ5	.042	-.116	-.064	-.171	.821 ^a

a. Measures of Sampling Adequacy(MSA)

Communalities

	Initial	Extraction
SQ1	1.000	.408
SQ2	1.000	.352
SQ3	1.000	.796
SQ4	1.000	.631
SQ5	1.000	.230

Extraction Method: Principal Component Analysis.

Total Variance Explained

Component	Initial Eigenvalues			Extraction Sums of Squared Loadings		
	Total	% of Variance	Cumulative %	Total	% of Variance	Cumulative %
1	2.417	48.346	48.346	2.417	48.346	48.346
2	.943	18.861	67.207			
3	.798	15.954	83.160			
4	.574	11.478	94.638			
5	.268	5.362	100.000			

Extraction Method: Principal Component Analysis.

Component Matrix^a

	Component
	1
SQ1	.639
SQ2	.593
SQ3	.892
SQ4	.794
SQ5	.480

Extraction Method:
Principal Component
Analysis.

a. 1 components
extracted.

Reliability**Case Processing Summary**

		N	%
Cases	Valid	30	96.8
	Excluded ^a	1	3.2
	Total	31	100.0

a. Listwise deletion based on all
variables in the procedure.

Reliability Statistics

Cronbach's Alpha	Cronbach's Alpha Based on Standardized Items	N of Items
.718	.715	5

Item Statistics

	Mean	Std. Deviation	N
SQ1	3.50	.509	30
SQ2	3.17	.648	30
SQ3	2.80	.664	30
SQ4	2.83	.791	30
SQ5	3.07	.640	30

Summary Item Statistics

	Mean	Minimum	Maximum	Range	Maximum / Minimum	Variance	N of Items
Item Means	3.073	2.800	3.500	.700	1.250	.081	5
Item Variances	.431	.259	.626	.368	2.422	.017	5
Inter-Item Covariances	.146	.034	.345	.310	10.000	.007	5
Inter-Item Correlations	.335	.106	.656	.550	6.187	.028	5

Scale Statistics

Mean	Variance	Std. Deviation	N of Items
15.37	5.068	2.251	5

Responsiveness/
Daya Tanggap

Correlation Matrix^a

	SQ6	SQ7	SQ8	SQ9	
Correlation	SQ6	1.000	.747	.532	.582
	SQ7	.747	1.000	.428	.595
	SQ8	.532	.428	1.000	.779
	SQ9	.582	.595	.779	1.000
Sig. (1-tailed)	SQ6		.000	.001	.000
	SQ7	.000		.009	.000
	SQ8	.001	.009		.000
	SQ9	.000	.000	.000	

a. Determinant = .098

KMO and Bartlett's Test

Kaiser-Meyer-Olkin Measure of Sampling Adequacy.	.674
Bartlett's Test of Sphericity	Approx. Chi-Square
	62.367
	df
	6
	Sig.
	.000

Anti-image Matrices

		SQ6	SQ7	SQ8	SQ9
Anti-image	SQ6	.387	-.245	-.094	-.001
Covariance	SQ7	-.245	.385	.079	-.123
	SQ8	-.094	.079	.367	-.235
	SQ9	-.001	-.123	-.235	.309
Anti-image	SQ6	.718 ^a	-.633	-.250	-.003
Correlation	SQ7	-.633	.657 ^a	.211	-.355
	SQ8	-.250	.211	.643 ^a	-.698
	SQ9	-.003	-.355	-.698	.679 ^a

a. Measures of Sampling Adequacy(MSA)

Communalities

	Initial	Extraction
SQ6	1.000	.722
SQ7	1.000	.675
SQ8	1.000	.660
SQ9	1.000	.777

Extraction Method: Principal Component Analysis.

Total Variance Explained

Component	Initial Eigenvalues			Extraction Sums of Squared Loadings		
	Total	% of Variance	Cumulative %	Total	% of Variance	Cumulative %
1	2.834	70.839	70.839	2.834	70.839	70.839
2	.711	17.769	88.609			
3	.285	7.135	95.744			
4	.170	4.256	100.000			

Extraction Method: Principal Component Analysis.

Component Matrix^a

	Component
	1
SQ6	.850
SQ7	.822
SQ8	.813
SQ9	.881

Extraction Method:
Principal Component
Analysis.

a. 1 components
extracted.

Reliability**Case Processing Summary**

		N	%
Cases	Valid	30	96.8
	Excluded ^a	1	3.2
	Total	31	100.0

a. Listwise deletion based on all
variables in the procedure.

Reliability Statistics

Cronbach's Alpha	Cronbach's Alpha Based on Standardized Items	N of Items
.862	.862	4

Item Statistics

	Mean	Std. Deviation	N
SQ6	3.77	.898	30
SQ7	3.50	.900	30
SQ8	2.97	.850	30
SQ9	2.80	1.031	30

Summary Item Statistics

	Mean	Minimum	Maximum	Range	Maximum / Minimum	Variance	N of Items
Item Means	3.258	2.800	3.767	.967	1.345	.204	4
Item Variances	.850	.723	1.062	.339	1.469	.022	4
Inter-Item Covariances	.518	.328	.683	.355	2.084	.015	4
Inter-Item Correlations	.610	.428	.779	.351	1.821	.016	4

Item-Total Statistics

	Scale Mean if Item Deleted	Scale Variance if Item Deleted	Corrected Item-Total Correlation	Squared Multiple Correlation	Cronbach's Alpha if Item Deleted
SQ6	9.27	5.720	.721	.613	.819
SQ7	9.53	5.844	.681	.615	.835
SQ8	10.07	6.064	.676	.633	.838
SQ9	10.23	5.013	.768	.691	.800

Scale Statistics

Mean	Variance	Std. Deviation	N of Items
13.03	9.620	3.102	4

Assurance/ Jaminan

Correlation Matrix^a

	SQ10	SQ11	SQ12	SQ13	
Correlation	SQ10	1.000	.157	.510	.386
	SQ11	.157	1.000	.481	.258
	SQ12	.510	.481	1.000	.656
	SQ13	.386	.258	.656	1.000
Sig. (1-tailed)	SQ10		.204	.002	.018
	SQ11	.204		.004	.084
	SQ12	.002	.004		.000
	SQ13	.018	.084	.000	

a. Determinant = .316

KMO and Bartlett's Test

Kaiser-Meyer-Olkin Measure of Sampling Adequacy.	.637
Bartlett's Test of Sphericity	Approx. Chi-Square
	30.936
	df
	6
	Sig.
	.000

Anti-image Matrices

		SQ10	SQ11	SQ12	SQ13
Anti-image Covariance	SQ10	.726	.082	-.204	-.044
	SQ11	.082	.754	-.239	.051
	SQ12	-.204	-.239	.399	-.262
	SQ13	-.044	.051	-.262	.563
Anti-image Correlation	SQ10	.730 ^a	.111	-.379	-.069
	SQ11	.111	.608 ^a	-.435	.078
	SQ12	-.379	-.435	.590 ^a	-.553
	SQ13	-.069	.078	-.553	.670 ^a

a. Measures of Sampling Adequacy(MSA)

Communalities

	Initial	Extraction
SQ10	1.000	.462
SQ11	1.000	.348
SQ12	1.000	.825
SQ13	1.000	.633

Extraction Method: Principal Component Analysis.

Total Variance Explained

Component	Initial Eigenvalues			Extraction Sums of Squared Loadings		
	Total	% of Variance	Cumulative %	Total	% of Variance	Cumulative %
1	2.269	56.725	56.725	2.269	56.725	56.725
2	.859	21.487	78.212			
3	.603	15.077	93.289			
4	.268	6.711	100.000			

Extraction Method: Principal Component Analysis.

Component Matrix^a

	Component
	1
SQ10	.680
SQ11	.590
SQ12	.908
SQ13	.796

Extraction Method:
Principal Component
Analysis.

a. 1 components
extracted.

Reliability**Case Processing Summary**

		N	%
Cases	Valid	30	96.8
	Excluded ^a	1	3.2
	Total	31	100.0

a. Listwise deletion based on all
variables in the procedure.

Reliability Statistics

Cronbach's Alpha	Cronbach's Alpha Based on Standardized Items	N of Items
.732	.734	4

Item Statistics

	Mean	Std. Deviation	N
SQ10	3.50	.509	30
SQ11	3.17	.648	30
SQ12	2.80	.664	30
SQ13	2.83	.791	30

Item-Total Statistics

	Scale Mean if Item Deleted	Scale Variance if Item Deleted	Corrected Item-Total Correlation	Squared Multiple Correlation	Cronbach's Alpha if Item Deleted
SQ10	8.80	2.855	.441	.274	.719
SQ11	9.13	2.671	.369	.246	.755
SQ12	9.50	1.983	.774	.601	.513
SQ13	9.47	1.982	.567	.437	.653

Scale Statistics

Mean	Variance	Std. Deviation	N of Items
12.30	3.872	1.968	4

Empathy/ Empati

Factor Analysis**Correlation Matrix^a**

		SQ14	SQ15	SQ16	SQ17	SQ18
Correlation	SQ14	1.000	.747	.532	.582	.340
	SQ15	.747	1.000	.428	.595	.188
	SQ16	.532	.428	1.000	.779	.359
	SQ17	.582	.595	.779	1.000	.395
	SQ18	.340	.188	.359	.395	1.000
Sig. (1-tailed)	SQ14		.000	.001	.000	.033
	SQ15	.000		.009	.000	.159
	SQ16	.001	.009		.000	.026
	SQ17	.000	.000	.000		.015
	SQ18	.033	.159	.026	.015	

a. Determinant = .078

KMO and Bartlett's Test

Kaiser-Meyer-Olkin Measure of Sampling Adequacy.	.688
Bartlett's Test of Sphericity	Approx. Chi-Square
	df
	Sig.
	67.728
	10
	.000

Anti-image Matrices

		SQ14	SQ15	SQ16	SQ17	SQ18
Anti-image Covariance	SQ14	.368	-.240	-.087	.014	-.120
	SQ15	-.240	.372	.075	-.126	.101
	SQ16	-.087	.075	.366	-.223	-.015
	SQ17	.014	-.126	-.223	.296	-.099
	SQ18	-.120	.101	-.015	-.099	.793
Anti-image Correlation	SQ14	.710 ^a	-.648	-.238	.042	-.223
	SQ15	-.648	.639 ^a	.202	-.379	.187
	SQ16	-.238	.202	.683 ^a	-.678	-.028
	SQ17	.042	-.379	-.678	.692 ^a	-.205
	SQ18	-.223	.187	-.028	-.205	.774 ^a

a. Measures of Sampling Adequacy(MSA)

Communalities

	Initial	Extraction
SQ14	1.000	.705
SQ15	1.000	.616
SQ16	1.000	.662
SQ17	1.000	.778
SQ18	1.000	.277

Extraction Method: Principal Component Analysis.

Total Variance Explained

Component	Initial Eigenvalues			Extraction Sums of Squared Loadings		
	Total	% of Variance	Cumulative %	Total	% of Variance	Cumulative %
1	3.038	60.752	60.752	3.038	60.752	60.752
2	.879	17.581	78.332			
3	.642	12.841	91.174			
4	.279	5.581	96.754			
5	.162	3.246	100.000			

Extraction Method: Principal Component Analysis.

Component Matrix^a

	Component
	1
SQ14	.839
SQ15	.785
SQ16	.814
SQ17	.882
SQ18	.527

Extraction Method:
Principal Component
Analysis.

a. 1 components
extracted.

Reliability**Case Processing Summary**

		N	%
Cases	Valid	30	100.0
	Excluded ^a	0	.0
	Total	30	100.0

a. Listwise deletion based on all
variables in the procedure.

Reliability Statistics

Cronbach's Alpha	Cronbach's Alpha Based on Standardized Items	N of Items
.837	.830	5

Item Statistics

	Mean	Std. Deviation	N
SQ14	3.77	.898	30
SQ15	3.50	.900	30
SQ16	2.97	.850	30
SQ17	2.80	1.031	30
SQ18	3.50	.509	30

Summary Item Statistics

	Mean	Minimum	Maximum	Range	Maximum / Minimum	Variance	N of Items
Item Means	3.307	2.800	3.767	.967	1.345	.165	5
Item Variances	.732	.259	1.062	.803	4.107	.086	5
Inter-Item Covariances	.371	.086	.683	.597	7.920	.044	5
Inter-Item Correlations	.494	.188	.779	.591	4.138	.033	5

Item-Total Statistics

	Scale Mean if Item Deleted	Scale Variance if Item Deleted	Corrected Item-Total Correlation	Squared Multiple Correlation	Cronbach's Alpha if Item Deleted
SQ14	12.77	6.875	.723	.632	.780
SQ15	13.03	7.137	.652	.628	.801
SQ16	13.57	7.220	.688	.634	.791
SQ17	13.73	6.064	.780	.704	.762
SQ18	13.03	9.620	.383	.207	.862

Scale Statistics

Mean	Variance	Std. Deviation	N of Items
16.53	11.085	3.329	5

Tangibles/ Bukti Fisik

Factor Analysis**Correlation Matrix^a**

		SQ19	SQ20	SQ21	SQ22
Correlation	SQ19	1.000	.428	.595	.188
	SQ20	.428	1.000	.779	.359
	SQ21	.595	.779	1.000	.395
	SQ22	.188	.359	.395	1.000
Sig. (1-tailed)	SQ19		.009	.000	.159
	SQ20	.009		.000	.026
	SQ21	.000	.000		.015
	SQ22	.159	.026	.015	

a. Determinant = .211

KMO and Bartlett's Test

Kaiser-Meyer-Olkin Measure of Sampling Adequacy.		.664
Bartlett's Test of Sphericity	Approx. Chi-Square	41.758
	df	6
	Sig.	.000

Anti-image Matrices

		SQ19	SQ20	SQ21	SQ22
Anti-image Covariance	SQ19	.641	.032	-.202	.042
	SQ20	.032	.388	-.233	-.048
	SQ21	-.202	-.233	.297	-.100
	SQ22	.042	-.048	-.100	.835
Anti-image Correlation	SQ19	.721 ^a	.065	-.462	.057
	SQ20	.065	.655 ^a	-.688	-.085
	SQ21	-.462	-.688	.606 ^a	-.201
	SQ22	.057	-.085	-.201	.863 ^a

a. Measures of Sampling Adequacy(MSA)

Communalities

	Initial	Extraction
SQ19	1.000	.514
SQ20	1.000	.741
SQ21	1.000	.854
SQ22	1.000	.320

Extraction Method: Principal Component Analysis.

Total Variance Explained

Component	Initial Eigenvalues			Extraction Sums of Squared Loadings		
	Total	% of Variance	Cumulative %	Total	% of Variance	Cumulative %
1	2.429	60.724	60.724	2.429	60.724	60.724
2	.829	20.719	81.442			
3	.553	13.818	95.260			
4	.190	4.740	100.000			

Extraction Method: Principal Component Analysis.

Component Matrix^a

	Component
	1
SQ19	.717
SQ20	.861
SQ21	.924
SQ22	.566

Extraction Method: Principal Component Analysis.

a. 1 components extracted.

Price perception (Persepsi harga).

Factor Analysis

Correlation Matrix^a

		PP23	PP24
Correlation	PP23	1.000	.779
	PP24	.779	1.000
Sig. (1-tailed)	PP23		.000
	PP24	.000	

a. Determinant = .393

KMO and Bartlett's Test

Kaiser-Meyer-Olkin Measure of Sampling Adequacy.		.500
Bartlett's Test of Sphericity	Approx. Chi-Square	25.690
	df	1
	Sig.	.000

Anti-image Matrices

		PP23	PP24
Anti-image	PP23	.393	-.306
Covariance	PP24	-.306	.393
Anti-image	PP23	.500 ^a	-.779
Correlation	PP24	-.779	.500 ^a

a. Measures of Sampling Adequacy(MSA)

Communalities

	Initial	Extraction
PP23	1.000	.890
PP24	1.000	.890

Extraction Method: Principal Component Analysis.

Total Variance Explained

Component	Initial Eigenvalues			Extraction Sums of Squared Loadings		
	Total	% of Variance	Cumulative %	Total	% of Variance	Cumulative %
1	1.779	88.958	88.958	1.779	88.958	88.958
2	.221	11.042	100.000			

Extraction Method: Principal Component Analysis.

Component Matrix^a

	Component
	1
PP23	.943
PP24	.943

Extraction Method:
Principal Component
Analysis.

a. 1 components
extracted.

Reliability**Case Processing Summary**

		N	%
Cases	Valid	30	100.0
	Excluded ^a	0	.0
	Total	30	100.0

a. Listwise deletion based on all
variables in the procedure.

Reliability Statistics

Cronbach's Alpha	Cronbach's Alpha Based on Standardized Items	N of Items
.867	.876	2

Item Statistics

	Mean	Std. Deviation	N
PP23	2.97	.850	30

PP24	2.80	1.031	30
------	------	-------	----

Summary Item Statistics

	Mean	Minimum	Maximum	Range	Maximum / Minimum	Variance	N of Items
Item Means	2.883	2.800	2.967	.167	1.060	.014	2
Item Variances	.893	.723	1.062	.339	1.469	.057	2
Inter-Item Covariances	.683	.683	.683	.000	1.000	.000	2
Inter-Item Correlations	.779	.779	.779	.000	1.000	.000	2

Item-Total Statistics

	Scale Mean if Item Deleted	Scale Variance if Item Deleted	Corrected Item-Total Correlation	Squared Multiple Correlation	Cronbach's Alpha if Item Deleted
PP23	2.80	1.062	.779	.607	.
PP24	2.97	.723	.779	.607	.

Scale Statistics

Mean	Variance	Std. Deviation	N of Items
5.77	3.151	1.775	2

Corporate Image (Citra Perusahaan).

Factor Analysis

Correlation Matrix^a

	IMA25	IMA26	IMA27	
Correlation	IMA25	1.000	.747	.532
	IMA26	.747	1.000	.428
	IMA27	.532	.428	1.000
Sig. (1-tailed)	IMA25		.000	.001
	IMA26	.000		.009
	IMA27	.001	.009	

a. Determinant = .316

KMO and Bartlett's Test

Kaiser-Meyer-Olkin Measure of Sampling Adequacy.		.635
Bartlett's Test of Sphericity	Approx. Chi-Square	31.268
	df	3
	Sig.	.000

Anti-image Matrices

		IMA25	IMA26	IMA27
Anti-image Covariance	IMA25	.387	-.280	-.186
	IMA26	-.280	.441	-.031
	IMA27	-.186	-.031	.715
Anti-image Correlation	IMA25	.590 ^a	-.678	-.353
	IMA26	-.678	.615 ^a	-.055
	IMA27	-.353	-.055	.785 ^a

a. Measures of Sampling Adequacy(MSA)

Communalities

	Initial	Extraction
IMA25	1.000	.832
IMA26	1.000	.759
IMA27	1.000	.558

Extraction Method: Principal Component Analysis.

Total Variance Explained

Component	Initial Eigenvalues			Extraction Sums of Squared Loadings		
	Total	% of Variance	Cumulative %	Total	% of Variance	Cumulative %
1	2.149	71.621	71.621	2.149	71.621	71.621
2	.610	20.334	91.955			
3	.241	8.045	100.000			

Extraction Method: Principal Component Analysis.

Component Matrix^a

	Component
	1
IMA2 5	.912
IMA2 6	.871
IMA2 7	.747

Extraction Method:
Principal Component
Analysis.

a. 1 components
extracted.

Reliability**Case Processing Summary**

		N	%
Cases	Valid	30	100.0
	Excluded ^a	0	.0
	Total	30	100.0

a. Listwise deletion based on all
variables in the procedure.

Reliability Statistics

Cronbach's Alpha	Cronbach's Alpha Based on Standardized Items	N of Items
.800	.798	3

Item Statistics

	Mean	Std. Deviation	N
IMA2 5	3.77	.898	30
IMA2 6	3.50	.900	30
IMA2 7	2.97	.850	30

Summary Item Statistics

	Mean	Minimum	Maximum	Range	Maximum / Minimum	Variance	N of Items
Item Means	3.411	2.967	3.767	.800	1.270	.166	3
Item Variances	.780	.723	.810	.087	1.121	.002	3
Inter-Item Covariances	.446	.328	.603	.276	1.842	.016	3
Inter-Item Correlations	.569	.428	.747	.319	1.745	.021	3

Item-Total Statistics

	Scale Mean if Item Deleted	Scale Variance if Item Deleted	Corrected Item-Total Correlation	Squared Multiple Correlation	Cronbach's Alpha if Item Deleted
IMA25	6.47	2.189	.760	.613	.599
IMA26	6.73	2.340	.676	.559	.694
IMA27	7.27	2.823	.513	.285	.855

Scale Statistics

Mean	Variance	Std. Deviation	N of Items
10.23	5.013	2.239	3

Customer satisfaction (Kepuasan Pelanggan).

Factor Analysis

Correlation Matrix^a

		CL28	CL29	CL30
Correlation	CS28	1.000	.428	.595
	CS29	.428	1.000	.779
	CS30	.595	.779	1.000
Sig. (1-tailed)	CS28		.009	.000
	CS29	.009		.000
	CS30	.000	.000	

a. Determinant = .253

KMO and Bartlett's Test

Kaiser-Meyer-Olkin Measure of Sampling Adequacy.		.608
Bartlett's Test of Sphericity	Approx. Chi-Square	37.370
	df	3
	Sig.	.000

Anti-image Matrices

		CL28	CL29	CL30
Anti-image Covariance	CS28	.643	.035	-.206
	CS29	.035	.391	-.251
	CS30	-.206	-.251	.309
Anti-image Correlation	CS28	.712 ^a	.070	-.461
	CS29	.070	.600 ^a	-.722
	CS30	-.461	-.722	.567 ^a

a. Measures of Sampling Adequacy(MSA)

Communalities

	Initial	Extraction
CS28	1.000	.585
CS29	1.000	.756
CS30	1.000	.872

Extraction Method: Principal Component Analysis.

Total Variance Explained

Component	Initial Eigenvalues			Extraction Sums of Squared Loadings		
	Total	% of Variance	Cumulative %	Total	% of Variance	Cumulative %
1	2.213	73.761	73.761	2.213	73.761	73.761
2	.595	19.845	93.606			
3	.192	6.394	100.000			

Extraction Method: Principal Component Analysis.

Component Matrix^a

	Component
	1
CS28	.765
CS29	.870
CS30	.934

Extraction Method:

Principal
Component
Analysis.

a. 1 components
extracted.

Reliability**Case Processing Summary**

		N	%
Cases	Valid	30	100.0
	Excluded ^a	0	.0
	Total	30	100.0

a. Listwise deletion based on all
variables in the procedure.

Reliability Statistics

Cronbach's Alpha	Cronbach's Alpha Based on Standardized Items	N of Items
.819	.819	3

Item Statistics

	Mean	Std. Deviation	N
CS28	3.50	.900	30
CS29	2.97	.850	30
CS30	2.80	1.031	30

Summary Item Statistics

	Mean	Minimum	Maximum	Range	Maximum / Minimum	Variance	N of Items
Item Means	3.089	2.800	3.500	.700	1.250	.134	3
Item Variances	.865	.723	1.062	.339	1.469	.031	3
Inter-Item Covariances	.521	.328	.683	.355	2.084	.026	3
Inter-Item Correlations	.601	.428	.779	.351	1.821	.025	3

Item-Total Statistics

	Scale Mean if Item Deleted	Scale Variance if Item Deleted	Corrected Item-Total Correlation	Squared Multiple Correlation	Cronbach's Alpha if Item Deleted
CS28	5.77	3.151	.550	.357	.867
CS29	6.30	2.976	.689	.609	.742
CS30	6.47	2.189	.810	.691	.599

Scale Statistics

Mean	Variance	Std. Deviation	N of Items
9.27	5.720	2.392	3

Customer loyalty (Loyalitas pelanggan).

Factor Analysis

Correlation Matrix^a

		CL31	CL32	CL33
Correlation	CL31	1.000	.747	.532
	CL32	.747	1.000	.428
	CL33	.532	.428	1.000
Sig. (1-tailed)	CL31		.000	.001
	CL32	.000		.009
	CL33	.001	.009	

a. Determinant = .316

KMO and Bartlett's Test

Kaiser-Meyer-Olkin Measure of Sampling Adequacy.		.635
Bartlett's Test of Sphericity	Approx. Chi-Square	31.268
	df	3
	Sig.	.000

Anti-image Matrices

		CL31	CL32	CL33
Anti-image Covariance	CL31	.387	-.280	-.186
	CL32	-.280	.441	-.031
	CL33	-.186	-.031	.715
Anti-image Correlation	CL31	.590 ^a	-.678	-.353
	CL32	-.678	.615 ^a	-.055
	CL33	-.353	-.055	.785 ^a

a. Measures of Sampling Adequacy(MSA)

Communalities

	Initial	Extraction
CL31	1.000	.832
CL32	1.000	.759
CL33	1.000	.558

Extraction Method: Principal Component Analysis.

Total Variance Explained

Component	Initial Eigenvalues			Extraction Sums of Squared Loadings		
	Total	% of Variance	Cumulative %	Total	% of Variance	Cumulative %
1	2.149	71.621	71.621	2.149	71.621	71.621
2	.610	20.334	91.955			
3	.241	8.045	100.000			

Extraction Method: Principal Component Analysis.

Component Matrix^a

	Component
	1
CL31	.912
CL32	.871
CL33	.747

Extraction Method:
Principal Component
Analysis.

a. 1 components
extracted.

Reliability**Case Processing Summary**

		N	%
Cases	Valid	30	100.0
	Excluded ^a	0	.0
	Total	30	100.0

a. Listwise deletion based on all
variables in the procedure.

Reliability Statistics

Cronbach's Alpha	Cronbach's Alpha Based on Standardized Items	N of Items
.800	.798	3

Item Statistics

	Mean	Std. Deviation	N
CL31	3.77	.898	30
CL32	3.50	.900	30
CL33	2.97	.850	30

Summary Item Statistics

	Mean	Minimum	Maximum	Range	Maximum / Minimum	Variance	N of Items
Item Means	3.411	2.967	3.767	.800	1.270	.166	3
Item Variances	.780	.723	.810	.087	1.121	.002	3
Inter-Item Covariances	.446	.328	.603	.276	1.842	.016	3
Inter-Item Correlations	.569	.428	.747	.319	1.745	.021	3

Item-Total Statistics

	Scale Mean if Item Deleted	Scale Variance if Item Deleted	Corrected Item-Total Correlation	Squared Multiple Correlation	Cronbach's Alpha if Item Deleted
CL31	6.47	2.189	.760	.613	.599
CL32	6.73	2.340	.676	.559	.694
CL33	7.27	2.823	.513	.285	.855

Scale Statistics

Mean	Variance	Std. Deviation	N of Items
10.23	5.013	2.239	3

Lampiran 4

Output Lisrel Ver 8.70 Confirmatory Factor Analysis (CFA)

DATE: 8/24/2015

TIME: 14:12

L I S R E L 8.70

BY

Karl G. Jöreskog & Dag Sörbom

This program is published exclusively by
 Scientific Software International, Inc.
 7383 N. Lincoln Avenue, Suite 100
 Lincolnwood, IL 60712, U.S.A.

Phone: (800)247-6113, (847)675-0720, Fax: (847)675-2140
 Copyright by Scientific Software International, Inc., 1981-

2004

Use of this program is subject to the terms specified in
 the

Universal Copyright Convention.
 Website: www.ssicentral.com

The following lines were read from file C:\Users\Kevin
 Gilbert\Documents\LISRELREVISI2\RAWPERTAMAPR3.pr3.PR2:

RAW DATA FROM FILE LATIHAN7.PSF

LATENT VARIABLES PRICE IMAGE SATIF LOYALITY SERV
 RELATIONSHIP
 REAL = SERV
 RESS = SERV
 ASS = SERV
 EMP = SERV
 TAN = SERV
 PP22 = PRICE
 PP23 = PRICE
 IMA24 = IMAGE
 IMA25 = IMAGE
 IMA26 = IMAGE
 CS27 = SATIF
 CS28 = SATIF
 CS29 = SATIF
 CL30 = LOYALITY
 CL31 = LOYALITY
 CL32 = LOYALITY

```

SET ERROR COVARIANCE OF SATIF AND IMAGE FREE
SET ERROR COVARIANCE OF TAN AND EMP FREE
SET ERROR COVARIANCE OF PP22 AND IMA24 FREE
SET ERROR COVARIANCE OF EMP AND IMA24 FREE
SET ERROR COVARIANCE OF CL31 AND CS27 FREE
SET ERROR COVARIANCE OF ASS AND REAL FREE
SET ERROR COVARIANCE OF EMP AND RESS FREE
SET ERROR COVARIANCE OF TAN AND RESS FREE
SET ERROR COVARIANCE OF TAN AND ASS FREE
SET ERROR COVARIANCE OF TAN AND REAL FREE
SET ERROR COVARIANCE OF RESS AND IMA25 FREE
SET ERROR COVARIANCE OF IMA26 AND IMA25 FREE

```

```

OPTIONS SC
PATH DIAGRAM
END OF PROGRAM

```

Sample Size = 160

Covariance Matrix

	PP22	PP23	IMA24	IMA25	IMA26
CS27	0.99				
PP22	0.99				
PP23	0.93	1.03			
IMA24	0.70	0.70	1.08		
IMA25	0.76	0.83	0.96	1.22	
IMA26	0.76	0.82	0.95	1.16	1.19
CS27	0.65	0.69	0.79	0.88	0.89
1.09					
CS28	0.62	0.64	0.73	0.84	0.82
1.00					
CS29	0.61	0.64	0.68	0.74	0.73
0.91					
CL30	0.47	0.49	0.37	0.51	0.46
0.60					
CL31	0.43	0.46	0.33	0.43	0.40
0.50					
CL32	0.47	0.49	0.39	0.53	0.51
0.64					
REAL	0.30	0.31	0.53	0.54	0.57
0.54					
RESS	0.29	0.32	0.50	0.50	0.56
0.56					
ASS	0.31	0.33	0.51	0.54	0.58
0.57					

0.80	EMP	0.54	0.57	0.79	0.77	0.81
0.71	TAN	0.68	0.72	0.70	0.76	0.75

Covariance Matrix

	CS28	CS29	CL30	CL31	CL32	
REAL	-----	-----	-----	-----	-----	-

CS28	1.05					
CS29	0.90	1.02				
CL30	0.60	0.68	0.98			
CL31	0.53	0.63	0.73	0.84		
CL32	0.63	0.72	0.77	0.69	0.94	
REAL	0.55	0.45	0.27	0.29	0.28	
1.00	RESS	0.55	0.46	0.27	0.29	0.30
0.89	ASS	0.54	0.46	0.26	0.27	0.32
0.93	EMP	0.77	0.70	0.40	0.40	0.43
0.80	TAN	0.66	0.68	0.53	0.45	0.50
0.31						

Covariance Matrix

	RESS	ASS	EMP	TAN
RESS	1.00			
ASS	0.89	1.00		
EMP	0.79	0.81	1.00	
TAN	0.29	0.28	0.61	1.00

Number of Iterations = 27

LISREL Estimates (Maximum Likelihood)

Measurement Equations

PP22 = 0.93*PRICE, Errorvar.= 0.13 , R² = 0.87
 (0.061) (0.026)
 15.38 4.86

PP23 = 1.01*PRICE, Errorvar.= 0.014 , R² = 0.99
 (0.059) (0.026)
 17.17 0.56

IMA24 = 0.90*IMAGE, Errorvar.= 0.23 , R² = 0.77
 (0.064) (0.034)
 13.96 6.83

IMA25 = 1.02*IMAGE, Errorvar.= 0.14 , R² = 0.88
 (0.066) (0.034)
 15.44 4.12

IMA26 = 1.03*IMAGE, Errorvar.= 0.13 , R² = 0.89
 (0.066) (0.033)
 15.60 3.93

CS27 = 1.01*SATIF, Errorvar.= 0.077 , R² = 0.93
 (0.061) (0.015)
 16.58 4.98

CS28 = 0.98*SATIF, Errorvar.= 0.087 , R² = 0.92
 (0.060) (0.015)
 16.33 5.71

CS29 = 0.92*SATIF, Errorvar.= 0.18 , R² = 0.82
 (0.062) (0.023)
 14.86 7.68

CL30 = 0.89*LOYALITY, Errorvar.= 0.19 , R² = 0.80
 (0.062) (0.032)
 14.28 6.03

CL31 = 0.79*LOYALITY, Errorvar.= 0.19 , R² = 0.77
 (0.057) (0.029)
 13.82 6.45

CL32 = 0.87*LOYALITY, Errorvar.= 0.18 , R² = 0.81
 (0.061) (0.030)
 14.30 6.00

REAL = 0.81*SERV, Errorvar.= 0.34 , R² = 0.66
 (0.067) (0.046)
 12.16 7.52

RESS = 1.01*SERV, Errorvar.= -0.020 , R² = 1.02
 (0.061) (0.055)
 16.41 -0.36

W_A_R_N_I_N_G : Error variance is negative.

ASS = 0.82*SERV, Errorvar.= 0.33 , R² = 0.67
 (0.067) (0.045)
 12.27 7.32

EMP = 1.03*SERV, Errorvar.= -0.085 , R² = 1.09

(0.058)	(0.053)
17.68	-1.60

W_A_R_N_I_N_G : Error variance is negative.

TAN = 1.03*SERV, Errorvar.= -0.17 , R ² = 1.18
(0.10) (0.16)
10.12 -1.02

W_A_R_N_I_N_G : Error variance is negative.

Error Covariance for IMA24 and PP22 = 0.054
(0.016)
3.38

Error Covariance for IMA26 and IMA25 = 0.090
(0.031)
2.87

Error Covariance for CL31 and CS27 = -0.05
(0.015)
-3.52

Error Covariance for RESS and IMA25 = -0.04
(0.011)
-3.67

Error Covariance for ASS and REAL = 0.27
(0.044)
6.14

Error Covariance for EMP and IMA24 = 0.062
(0.018)
3.55

Error Covariance for EMP and RESS = -0.28
(0.049)
-5.69

Error Covariance for TAN and REAL = -0.49
(0.084)
-5.81

Error Covariance for TAN and RESS = -0.65
(0.11)
-5.72

Error Covariance for TAN and ASS = -0.54
(0.085)
-6.35

Error Covariance for TAN and EMP = -0.54
(0.12)

-4.63

Correlation Matrix of Independent Variables

	PRICE	IMAGE	SATIF	LOYALITY	SERV
PRICE	1.00				
IMAGE	0.78 (0.04) 21.95	1.00			
SATIF	0.68 (0.05) 14.88	0.82 (0.03) 26.06	1.00		
LOYALITY	0.56 (0.06) 9.69	0.52 (0.06) 8.12	0.73 (0.04) 17.26	1.00	
SERV	0.55 (0.05) 11.13	0.65 (0.05) 13.96	0.65 (0.05) 14.02	0.48 (0.05) 9.02	1.00

Goodness of Fit Statistics

Degrees of Freedom = 83

Minimum Fit Function Chi-Square = 241.34 (P = 0.0)

Normal Theory Weighted Least Squares Chi-Square = 208.21 (P = 0.00)

Estimated Non-centrality Parameter (NCP) = 125.21

90 Percent Confidence Interval for NCP = (86.52 ; 171.59)

Minimum Fit Function Value = 1.52

Population Discrepancy Function Value (F0) = 0.79

90 Percent Confidence Interval for F0 = (0.54 ; 1.08)

Root Mean Square Error of Approximation (RMSEA) = 0.097

90 Percent Confidence Interval for RMSEA = (0.081 ; 0.11)

P-Value for Test of Close Fit (RMSEA < 0.05) = 0.00

Expected Cross-Validation Index (ECVI) = 1.98

90 Percent Confidence Interval for ECVI = (1.73 ; 2.27)

ECVI for Saturated Model = 1.71

ECVI for Independence Model = 43.93

Chi-Square for Independence Model with 120 Degrees of Freedom = 6952.83

Independence AIC = 6984.83

Model AIC = 314.21
 Saturated AIC = 272.00
 Independence CAIC = 7050.03
 Model CAIC = 530.19
 Saturated CAIC = 826.22

Normed Fit Index (NFI) = 0.97
 Non-Normed Fit Index (NNFI) = 0.97
 Parsimony Normed Fit Index (PNFI) = 0.67
 Comparative Fit Index (CFI) = 0.98
 Incremental Fit Index (IFI) = 0.98
 Relative Fit Index (RFI) = 0.95

Critical N (CN) = 77.35

Root Mean Square Residual (RMR) = 0.066
 Standardized RMR = 0.066
 Goodness of Fit Index (GFI) = 0.86
 Adjusted Goodness of Fit Index (AGFI) = 0.77
 Parsimony Goodness of Fit Index (PGFI) = 0.52

The Modification Indices Suggest to Add the

Path to	from	Decrease in Chi-Square	New Estimate
CS29	LOYALITY	33.6	0.35
RESS	PRICE	28.8	-0.32
RESS	IMAGE	40.3	-0.50
RESS	SATIF	27.0	-0.39
RESS	LOYALITY	8.7	-0.17
EMP	IMAGE	26.6	0.39
EMP	SATIF	38.8	0.43
TAN	PRICE	13.9	0.39

Standardized Solution

LAMBDA-X

	PRICE	IMAGE	SATIF	LOYALITY	SERV
	-----	-----	-----	-----	-----
PP22	0.93	- -	- -	- -	- -
PP23	1.01	- -	- -	- -	- -
IMA24	- -	0.90	- -	- -	- -
IMA25	- -	1.02	- -	- -	- -
IMA26	- -	1.03	- -	- -	- -
CS27	- -	- -	1.01	- -	- -
CS28	- -	- -	0.98	- -	- -
CS29	- -	- -	0.92	- -	- -
CL30	- -	- -	- -	0.89	- -
CL31	- -	- -	- -	0.79	- -
CL32	- -	- -	- -	0.87	- -
REAL	- -	- -	- -	- -	0.81

RESS	--	--	--	--	1.01
ASS	--	--	--	--	0.82
EMP	--	--	--	--	1.03
TAN	--	--	--	--	1.03

PHI

	PRICE	IMAGE	SATIF	LOYALITY	SERV
	-----	-----	-----	-----	-----
PRICE	1.00				
IMAGE	0.78	1.00			
SATIF	0.68	0.82	1.00		
LOYALITY	0.56	0.52	0.73	1.00	
SERV	0.55	0.65	0.65	0.48	1.00

Completely Standardized Solution

LAMBDA-X

	PRICE	IMAGE	SATIF	LOYALITY	SERV
	-----	-----	-----	-----	-----
PP22	0.93	--	--	--	--
PP23	0.99	--	--	--	--
IMA24	--	0.88	--	--	--
IMA25	--	0.94	--	--	--
IMA26	--	0.94	--	--	--
CS27	--	--	0.96	--	--
CS28	--	--	0.96	--	--
CS29	--	--	0.91	--	--
CL30	--	--	--	0.90	--
CL31	--	--	--	0.88	--
CL32	--	--	--	0.90	--
REAL	--	--	--	--	0.81
RESS	--	--	--	--	1.01
ASS	--	--	--	--	0.82
EMP	--	--	--	--	1.04
TAN	--	--	--	--	1.09

PHI

	PRICE	IMAGE	SATIF	LOYALITY	SERV
	-----	-----	-----	-----	-----
PRICE	1.00				
IMAGE	0.78	1.00			
SATIF	0.68	0.82	1.00		
LOYALITY	0.56	0.52	0.73	1.00	
SERV	0.55	0.65	0.65	0.48	1.00

THETA-DELTA						
	PP22	PP23	IMA24	IMA25	IMA26	
CS27	-----	-----	-----	-----	-----	-

PP22	0.13					
PP23	- -	0.01				
IMA24	0.05	- -	0.23			
IMA25	- -	- -	- -	0.12		
IMA26	- -	- -	- -	0.08	0.11	
CS27	- -	- -	- -	- -	- -	
0.07						
CS28	- -	- -	- -	- -	- -	
- -						
CS29	- -	- -	- -	- -	- -	
- -						
CL30	- -	- -	- -	- -	- -	
- -						
CL31	- -	- -	- -	- -	- -	
-0.05						
CL32	- -	- -	- -	- -	- -	
- -						
REAL	- -	- -	- -	- -	- -	
- -						
RESS	- -	- -	- -	-0.04	- -	
- -						
ASS	- -	- -	- -	- -	- -	
- -						
EMP	- -	- -	0.06	- -	- -	
- -						
TAN	- -	- -	- -	- -	- -	
- -						
THETA-DELTA						
	CS28	CS29	CL30	CL31	CL32	
REAL	-----	-----	-----	-----	-----	-

CS28	0.08					
CS29	- -	0.18				
CL30	- -	- -	0.20			
CL31	- -	- -	- -	0.23		
CL32	- -	- -	- -	- -	0.19	
REAL	- -	- -	- -	- -	- -	
0.34						
RESS	- -	- -	- -	- -	- -	
- -						
ASS	- -	- -	- -	- -	- -	
0.27						
EMP	- -	- -	- -	- -	- -	
- -						

TAN - - - - - - - - - -
 -0.52

THETA-DELTA

	RESS	ASS	EMP	TAN
	-----	-----	-----	-----
RESS	-0.02			
ASS	- -	0.33		
EMP	-0.28	- -	-0.09	
TAN	-0.69	-0.57	-0.57	-0.18

Time used: 0.047 Seconds

Lampiran 5

Path Diagram Confirmatory Factor Analysis (t-value)

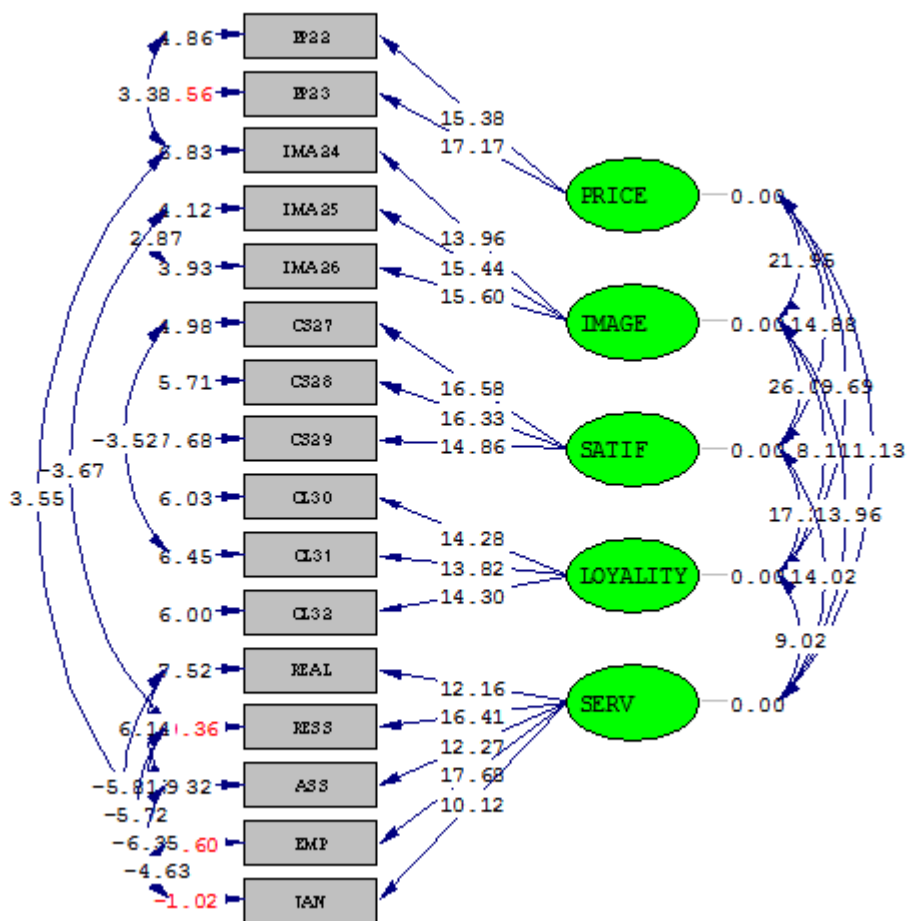

Lampiran 6

Path Diagram Confirmatory Factor Analysis (standardized solution)

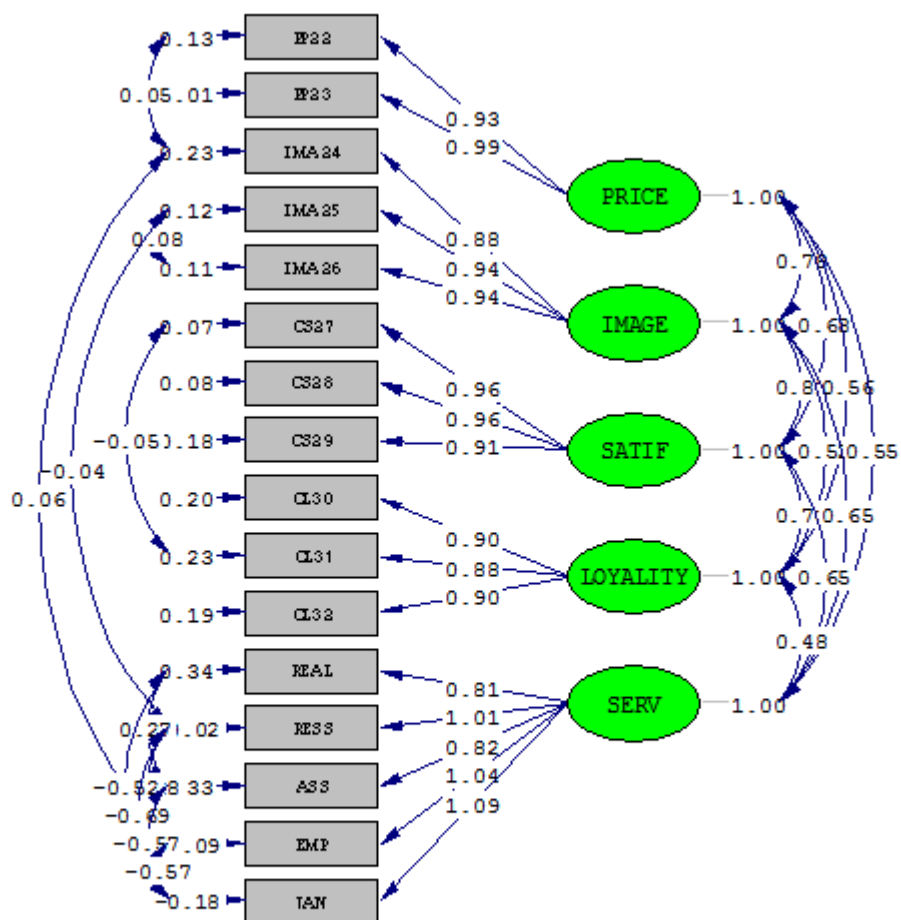

Chi-Square=208.21, df=83, P-value=0.00000, RMSEA=0.097

Lampiran 7

Output Lisrel Ver 8.70 Model Struktural

DATE: 8/23/2015
 TIME: 21:24

L I S R E L 8.70

BY

Karl G. Jöreskog & Dag Sörbom

This program is published exclusively by
 Scientific Software International, Inc.
 7383 N. Lincoln Avenue, Suite 100
 Lincolnwood, IL 60712, U.S.A.

Phone: (800)247-6113, (847)675-0720, Fax: (847)675-2140
 Copyright by Scientific Software International, Inc., 1981-

2004

Use of this program is subject to the terms specified in
 the

Universal Copyright Convention.
 Website: www.ssicentral.com

The following lines were read from file C:\Users\Kevin
 Gilbert\Documents\LISRELREVISI2\RAWPERTAMAPR2.pr2:

RAW DATA FROM FILE LATIHAN7.PSF

LATENT VARIABLES PRICE IMAGE SATIF LOYALITY SERV
 RELATIONSHIP
 REAL = SERV
 RESS = SERV
 ASS = SERV
 EMP = SERV
 TAN = SERV
 PP22 = PRICE
 PP23 = PRICE
 IMA24 = IMAGE
 IMA25 = IMAGE
 IMA26 = IMAGE
 CS27 = SATIF
 CS28 = SATIF
 CS29 = SATIF
 CL30 = LOYALITY

CL31 = LOYALTY
 CL32 = LOYALTY

IMAGE = SERV
 SATIF = SERV
 LOYALTY = IMAGE SERV SATIF PRICE

SET ERROR COVARIANCE OF SATIF AND IMAGE FREE
 SET ERROR COVARIANCE OF TAN AND EMP FREE
 SET ERROR COVARIANCE OF PP22 AND IMA24 FREE
 SET ERROR COVARIANCE OF EMP AND IMA24 FREE
 SET ERROR COVARIANCE OF CL31 AND CS27 FREE
 SET ERROR COVARIANCE OF ASS AND REAL FREE
 SET ERROR COVARIANCE OF EMP AND RESS FREE
 SET ERROR COVARIANCE OF TAN AND RESS FREE
 SET ERROR COVARIANCE OF TAN AND ASS FREE
 SET ERROR COVARIANCE OF TAN AND REAL FREE
 SET ERROR COVARIANCE OF RESS AND IMA25 FREE
 SET ERROR COVARIANCE OF IMA26 AND IMA25 FREE

OPTIONS SC
 PATH DIAGRAM
 END OF PROGRAM

Sample Size = 160

Covariance Matrix

	IMA24	IMA25	IMA26	CS27	CS28	
CS29						
IMA24	1.08					
IMA25	0.96	1.22				
IMA26	0.95	1.16	1.19			
CS27	0.79	0.88	0.89	1.09		
CS28	0.73	0.84	0.82	1.00	1.05	
CS29	0.68	0.74	0.73	0.91	0.90	
1.02						
CL30	0.37	0.51	0.46	0.60	0.60	
0.68						
CL31	0.33	0.43	0.40	0.50	0.53	
0.63						
CL32	0.39	0.53	0.51	0.64	0.63	
0.72						
PP22	0.70	0.76	0.76	0.65	0.62	
0.61						
PP23	0.70	0.83	0.82	0.69	0.64	
0.64						
REAL	0.53	0.54	0.57	0.54	0.55	
0.45						

0.46	RESS	0.50	0.50	0.56	0.56	0.55
0.46	ASS	0.51	0.54	0.58	0.57	0.54
0.70	EMP	0.79	0.77	0.81	0.80	0.77
0.68	TAN	0.70	0.76	0.75	0.71	0.66

Covariance Matrix

	CL30	CL31	CL32	PP22	PP23	
REAL	-----	-----	-----	-----	-----	-

CL30	0.98					
CL31	0.73	0.84				
CL32	0.77	0.69	0.94			
PP22	0.47	0.43	0.47	0.99		
PP23	0.49	0.46	0.49	0.93	1.03	
REAL	0.27	0.29	0.28	0.30	0.31	
1.00						
RESS	0.27	0.29	0.30	0.29	0.32	
0.89						
ASS	0.26	0.27	0.32	0.31	0.33	
0.93						
EMP	0.40	0.40	0.43	0.54	0.57	
0.80						
TAN	0.53	0.45	0.50	0.68	0.72	
0.31						

Covariance Matrix

	RESS	ASS	EMP	TAN
RESS	1.00			
ASS	0.89	1.00		
EMP	0.79	0.81	1.00	
TAN	0.29	0.28	0.61	1.00

Number of Iterations = 32

LISREL Estimates (Maximum Likelihood)

Measurement Equations

$$\text{IMA24} = 0.91 \cdot \text{IMAGE}, \text{ Errorvar.} = 0.22, R^2 = 0.79$$

(0.036)
6.05

IMA25 = 1.01*IMAGE, Errorvar.= 0.16 , R² = 0.87
 (0.058) (0.038)
 17.19 4.13

IMA26 = 1.02*IMAGE, Errorvar.= 0.15 , R² = 0.87
 (0.058) (0.038)
 17.44 4.06

CS27 = 1.01*SATIF, Errorvar.= 0.076 , R² = 0.93
 (0.015)
 4.92

CS28 = 0.98*SATIF, Errorvar.= 0.086 , R² = 0.92
 (0.033) (0.015)
 29.85 5.65

CS29 = 0.92*SATIF, Errorvar.= 0.18 , R² = 0.82
 (0.040) (0.023)
 22.88 7.70

CL30 = 0.86*LOYALITY, Errorvar.= 0.19 , R² = 0.79
 (0.032)
 6.02

CL31 = 0.77*LOYALITY, Errorvar.= 0.19 , R² = 0.76
 (0.050) (0.029)
 15.27 6.42

CL32 = 0.84*LOYALITY, Errorvar.= 0.18 , R² = 0.79
 (0.053) (0.030)
 15.93 5.98

PP22 = 0.93*PRICE, Errorvar.= 0.12 , R² = 0.88
 (0.061) (0.037)
 15.16 3.21

PP23 = 1.00*PRICE, Errorvar.= 0.027 , R² = 0.97
 (0.061) (0.040)
 16.42 0.67

REAL = 0.85*SERV, Errorvar.= 0.27 , R² = 0.73
 (0.064) (0.035)
 13.30 7.81

RESS = 0.96*SERV, Errorvar.= 0.077 , R² = 0.92
 (0.061) (0.040)
 15.69 1.94

ASS = 0.86*SERV, Errorvar.= 0.26 , R² = 0.74
 (0.064) (0.035)

(0.066)
-5.06

Structural Equations

IMAGE = 0.68*SERV, Errorvar.= 0.54 , R² = 0.46
(0.076) (0.073)
9.00 7.38

SATIF = 0.68*SERV, Errorvar.= 0.53 , R² = 0.47
(0.070) (0.062)
9.79 8.57

LOYALTY = - 0.47*IMAGE + 0.89*SATIF + 0.31*PRICE + 0.063*SERV,
Errorvar.= 0.43 , R² = 0.57

(0.073) (0.13) (0.13) (0.070) (0.063)
-3.68 6.98 4.42 0.99
5.96

Error Covariance for SATIF and IMAGE = 0.35
(0.054)
6.52

Reduced Form Equations

IMAGE = 0.0*PRICE + 0.68*SERV, Errorvar.= 0.54, R² = 0.46
(0.076)
9.00

SATIF = 0.0*PRICE + 0.68*SERV, Errorvar.= 0.53, R² = 0.47
(0.070)
9.79

LOYALTY = 0.31*PRICE + 0.35*SERV, Errorvar.= 0.68, R² = 0.32
(0.070) (0.070)
4.42 5.03

Correlation Matrix of Independent Variables

	PRICE	SERV
PRICE	1.00	
SERV	0.47 (0.05) 8.62	1.00

Covariance Matrix of Latent Variables

	IMAGE	SATIF	LOYALITY	PRICE	SERV
	-----	-----	-----	-----	-----
IMAGE	1.00				
SATIF	0.82	1.00			
LOYALITY	0.40	0.65	1.00		
PRICE	0.32	0.32	0.47	1.00	
SERV	0.68	0.68	0.50	0.47	1.00

Goodness of Fit Statistics

Degrees of Freedom = 85
 Minimum Fit Function Chi-Square = 330.88 (P = 0.0)
 Normal Theory Weighted Least Squares Chi-Square = 291.07 (P = 0.0)
 Estimated Non-centrality Parameter (NCP) = 206.07
 90 Percent Confidence Interval for NCP = (157.96 ; 261.78)

Minimum Fit Function Value = 2.08
 Population Discrepancy Function Value (F0) = 1.30
 90 Percent Confidence Interval for F0 = (0.99 ; 1.65)
 Root Mean Square Error of Approximation (RMSEA) = 0.12
 90 Percent Confidence Interval for RMSEA = (0.11 ; 0.14)
 P-Value for Test of Close Fit (RMSEA < 0.05) = 0.00

Expected Cross-Validation Index (ECVI) = 2.47
 90 Percent Confidence Interval for ECVI = (2.17 ; 2.82)
 ECVI for Saturated Model = 1.71
 ECVI for Independence Model = 43.93

Chi-Square for Independence Model with 120 Degrees of Freedom = 6952.83

Independence AIC = 6984.83
 Model AIC = 393.07
 Saturated AIC = 272.00
 Independence CAIC = 7050.03
 Model CAIC = 600.90
 Saturated CAIC = 826.22

Normed Fit Index (NFI) = 0.95
 Non-Normed Fit Index (NNFI) = 0.95
 Parsimony Normed Fit Index (PNFI) = 0.67
 Comparative Fit Index (CFI) = 0.96
 Incremental Fit Index (IFI) = 0.96
 Relative Fit Index (RFI) = 0.93

Critical N (CN) = 57.82

Root Mean Square Residual (RMR) = 0.15
 Standardized RMR = 0.15
 Goodness of Fit Index (GFI) = 0.81
 Adjusted Goodness of Fit Index (AGFI) = 0.70
 Parsimony Goodness of Fit Index (PGFI) = 0.51

The Modification Indices Suggest to Add the

Path to	from	Decrease in Chi-Square	New Estimate
CS27	IMAGE	8.1	0.17
CS29	LOYALITY	28.8	0.28
RESS	PRICE	29.9	-0.28
IMAGE	LOYALITY	26.7	0.93
IMAGE	PRICE	26.7	0.29

Standardized Solution

LAMBDA-Y

	IMAGE	SATIF	LOYALITY
	-----	-----	-----
IMA24	0.91	- -	- -
IMA25	1.01	- -	- -
IMA26	1.02	- -	- -
CS27	- -	1.01	- -
CS28	- -	0.98	- -
CS29	- -	0.92	- -
CL30	- -	- -	0.86
CL31	- -	- -	0.77
CL32	- -	- -	0.84

LAMBDA-X

	PRICE	SERV
	-----	-----
PP22	0.93	- -
PP23	1.00	- -
REAL	- -	0.85
RESS	- -	0.96
ASS	- -	0.86
EMP	- -	1.00
TAN	- -	0.85

BETA

	IMAGE	SATIF	LOYALITY
	-----	-----	-----
IMAGE	- -	- -	- -
SATIF	- -	- -	- -
LOYALITY	-0.47	0.89	- -

GAMMA

	PRICE	SERV
	-----	-----
IMAGE	- -	0.68
SATIF	- -	0.68
LOYALITY	0.31	0.06

Correlation Matrix of ETA and KSI

	IMAGE	SATIF	LOYALITY	PRICE	SERV
	-----	-----	-----	-----	-----
IMAGE	1.00				
SATIF	0.82	1.00			
LOYALITY	0.40	0.65	1.00		
PRICE	0.32	0.32	0.47	1.00	
SERV	0.68	0.68	0.50	0.47	1.00

PSI

	IMAGE	SATIF	LOYALITY
	-----	-----	-----
IMAGE	0.54		
SATIF	0.35	0.53	
LOYALITY	- -	- -	0.43

Regression Matrix ETA on KSI (Standardized)

	PRICE	SERV
	-----	-----
IMAGE	- -	0.68
SATIF	- -	0.68
LOYALITY	0.31	0.35

Completely Standardized Solution

LAMBDA-Y

	IMAGE	SATIF	LOYALITY
	-----	-----	-----
IMA24	0.89	- -	- -
IMA25	0.93	- -	- -
IMA26	0.93	- -	- -
CS27	- -	0.96	- -
CS28	- -	0.96	- -
CS29	- -	0.91	- -
CL30	- -	- -	0.89
CL31	- -	- -	0.87
CL32	- -	- -	0.89

LAMBDA-X

	PRICE	SERV
	-----	-----
PP22	0.94	- -
PP23	0.99	- -
REAL	- -	0.85
RESS	- -	0.96
ASS	- -	0.86
EMP	- -	1.01
TAN	- -	0.95

BETA

	IMAGE	SATIF	LOYALITY
	-----	-----	-----
IMAGE	- -	- -	- -
SATIF	- -	- -	- -
LOYALITY	-0.47	0.89	- -

GAMMA

	PRICE	SERV
	-----	-----
IMAGE	- -	0.68
SATIF	- -	0.68
LOYALITY	0.31	0.06

Correlation Matrix of ETA and KSI

	IMAGE	SATIF	LOYALITY	PRICE	SERV
	-----	-----	-----	-----	-----
IMAGE	1.00				
SATIF	0.82	1.00			
LOYALITY	0.40	0.65	1.00		
PRICE	0.32	0.32	0.47	1.00	
SERV	0.68	0.68	0.50	0.47	1.00

PSI

	IMAGE	SATIF	LOYALITY
	-----	-----	-----
IMAGE	0.54		
SATIF	0.35	0.53	
LOYALITY	- -	- -	0.43

THETA-EPS						
	IMA24	IMA25	IMA26	CS27	CS28	
CS29	-----	-----	-----	-----	-----	-

IMA24	0.21					
IMA25	- -	0.13				
IMA26	- -	0.09	0.13			
CS27	- -	- -	- -	0.07		
CS28	- -	- -	- -	- -	0.08	
CS29	- -	- -	- -	- -	- -	
0.18						
CL30	- -	- -	- -	- -	- -	
- -						
CL31	- -	- -	- -	-0.05	- -	
- -						
CL32	- -	- -	- -	- -	- -	
- -						

THETA-EPS			
	CL30	CL31	CL32
	-----	-----	-----
CL30	0.21		
CL31	- -	0.24	
CL32	- -	- -	0.21

THETA-DELTA-EPS						
	IMA24	IMA25	IMA26	CS27	CS28	
CS29	-----	-----	-----	-----	-----	-

PP22	0.05	- -	- -	- -	- -	
- -						
PP23	- -	- -	- -	- -	- -	
- -						
REAL	- -	- -	- -	- -	- -	
- -						
RESS	- -	-0.04	- -	- -	- -	
- -						
ASS	- -	- -	- -	- -	- -	
- -						
EMP	0.06	- -	- -	- -	- -	
- -						
TAN	- -	- -	- -	- -	- -	
- -						

THETA-DELTA-EPS

	CL30	CL31	CL32
	-----	-----	-----
PP22	- -	- -	- -
PP23	- -	- -	- -
REAL	- -	- -	- -
RESS	- -	- -	- -
ASS	- -	- -	- -
EMP	- -	- -	- -
TAN	- -	- -	- -

THETA-DELTA

	PP22	PP23	REAL	RESS	ASS	
EMP	-----	-----	-----	-----	-----	-----

PP22	0.12					
PP23	- -	0.03				
REAL	- -	- -	0.27			
RESS	- -	- -	- -	0.08		
ASS	- -	- -	0.20	- -	0.26	
EMP	- -	- -	- -	-0.19	- -	
-0.01						
TAN	- -	- -	-0.39	-0.49	-0.44	
-0.38						

THETA-DELTA

	TAN

TAN	0.09

Regression Matrix ETA on KSI (Standardized)

	PRICE	SERV
	-----	-----
IMAGE	- -	0.68
SATIF	- -	0.68
LOYALITY	0.31	0.35

Time used: 0.031 Seconds

Lampiran 8

SEM Diagram Model Struktural (t-value)

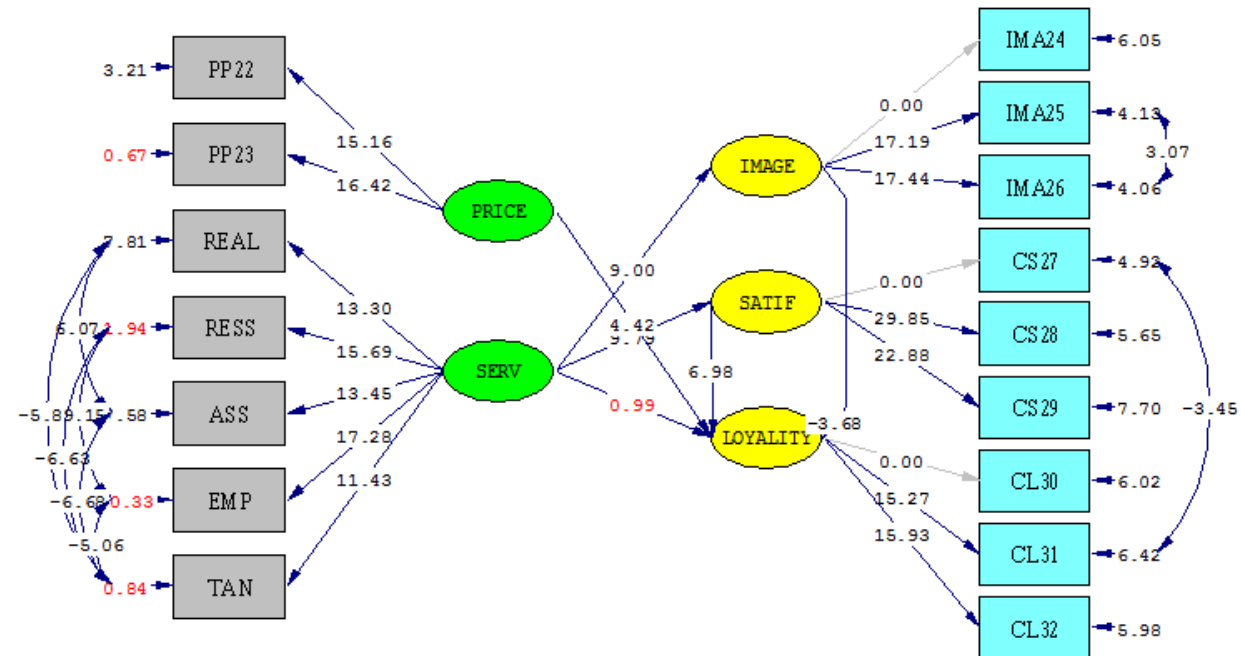

Chi-Square=291.07, df=85, P-value=0.00000, RMSEA=0.123

SEM Diagram Model Struktural (Standardized Solution)

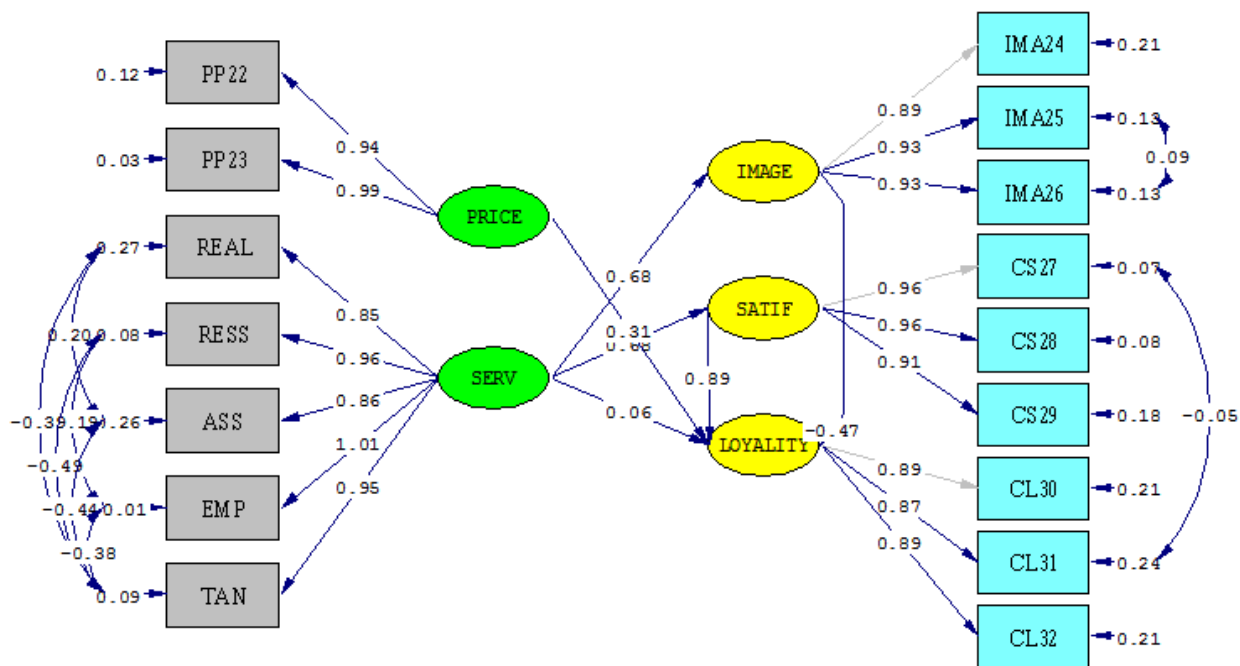

Chi-Square=291.07, df=85, P-value=0.00000, RMSEA=0.123

ONEWAY REAL RESS ASS EMP TAN PRICE IMAGE SATIF LOYALTY BY EDUCATION
 /STATISTICS HOMOGENEITY
 /PLOT MEANS
 /MISSING ANALYSIS.

Oneway

Test of Homogeneity of Variances

	Levene Statistic	df1	df2	Sig.
REAL	.165	2	155	.848
RESS	3.624	2	155	.029
ASS	.561	2	155	.572
EMP	.834	2	155	.436
TAN	.188	2	155	.829
PRICE	.993	2	155	.373
IMAGE	1.065	2	155	.347
SATIF	.261	2	155	.771
LOYALTY	4.512	2	155	.012

ANOVA

		Sum of Squares	df	Mean Square	F	Sig.
REAL	Between Groups	.950	4	.237	.233	.920
	Within Groups	158.050	155	1.020		
	Total	159.000	159			
RESS	Between Groups	1.460	4	.365	.359	.837
	Within Groups	157.540	155	1.016		
	Total	159.000	159			
ASS	Between Groups	.940	4	.235	.231	.921
	Within Groups	158.060	155	1.020		
	Total	159.000	159			
EMP	Between Groups	2.670	4	.667	.662	.619
	Within Groups	156.330	155	1.009		
	Total	159.000	159			
TAN	Between Groups	2.537	4	.634	.628	.643
	Within Groups	156.463	155	1.009		
	Total	159.000	159			

		Sum of Squares	df	Mean Square	F	Sig.
PRICE	Between Groups	1.370	4	.342	.337	.853
	Within Groups	157.630	155	1.017		
	Total	159.000	159			
IMAGE	Between Groups	1.769	4	.442	.436	.782
	Within Groups	157.231	155	1.014		
	Total	159.000	159			
SATIF	Between Groups	4.100	4	1.025	1.026	.396
	Within Groups	154.900	155	.999		
	Total	159.000	159			
LOYALTY	Between Groups	10.283	4	2.571	2.679	.034
	Within Groups	148.717	155	.959		
	Total	159.000	159			

Means Plots

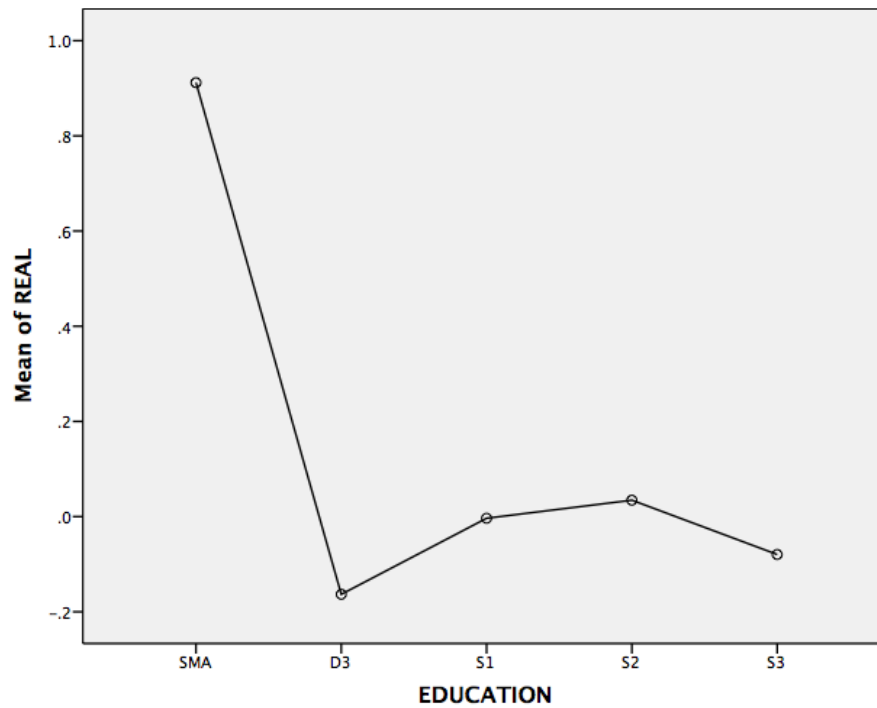

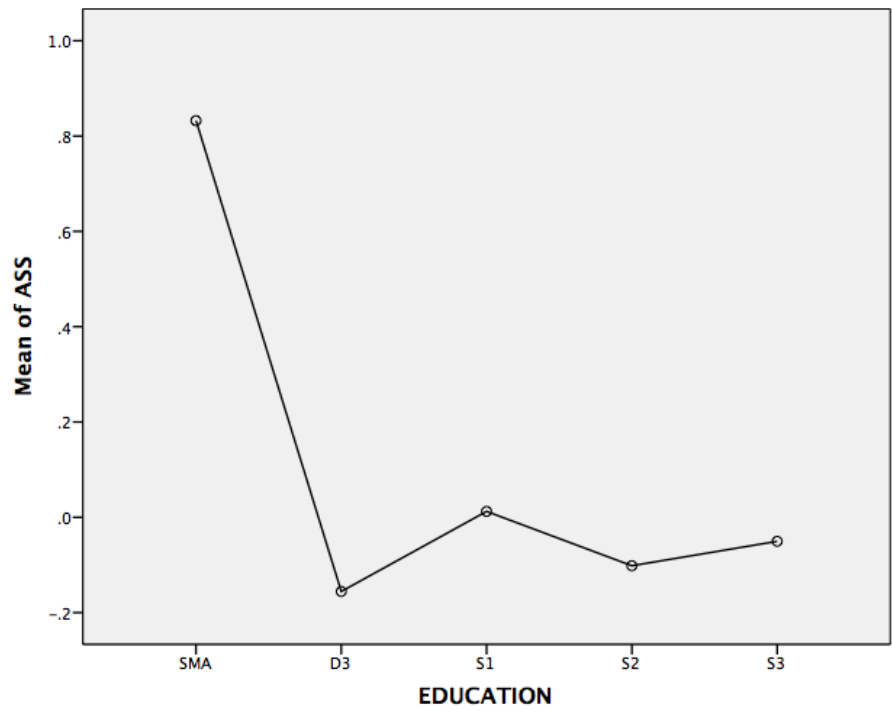
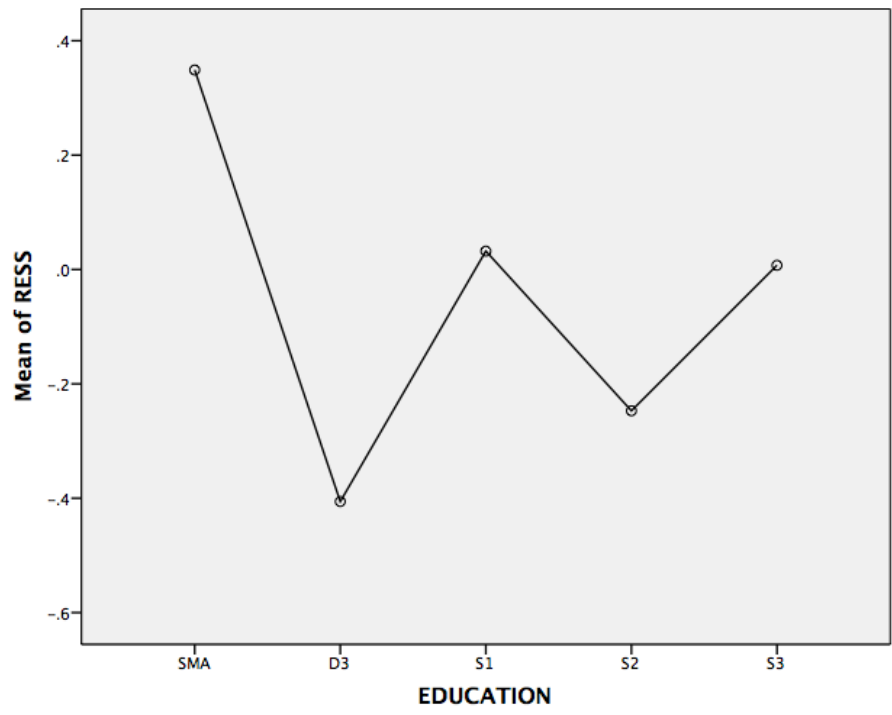

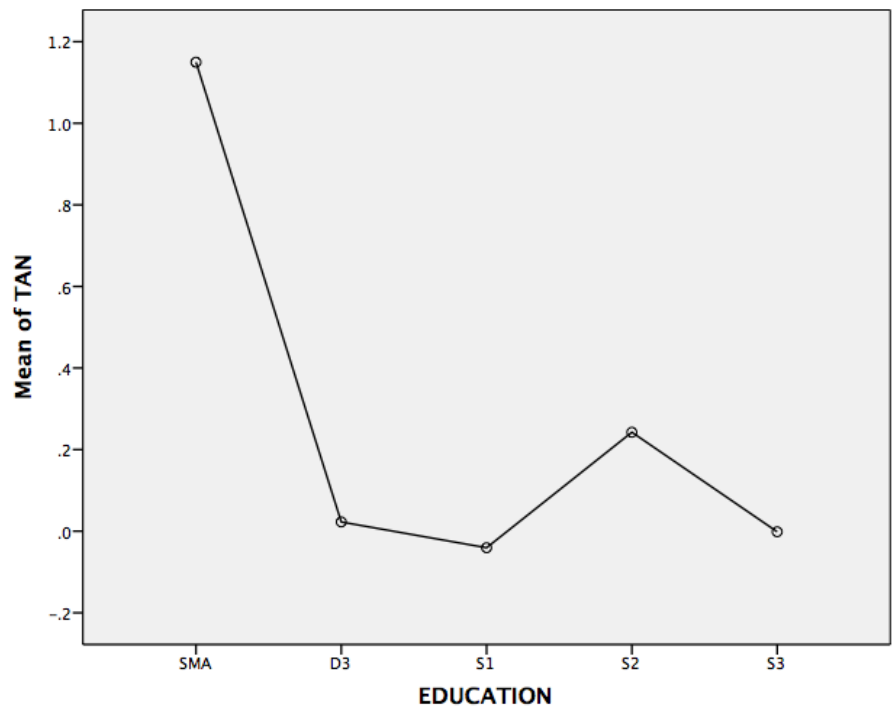
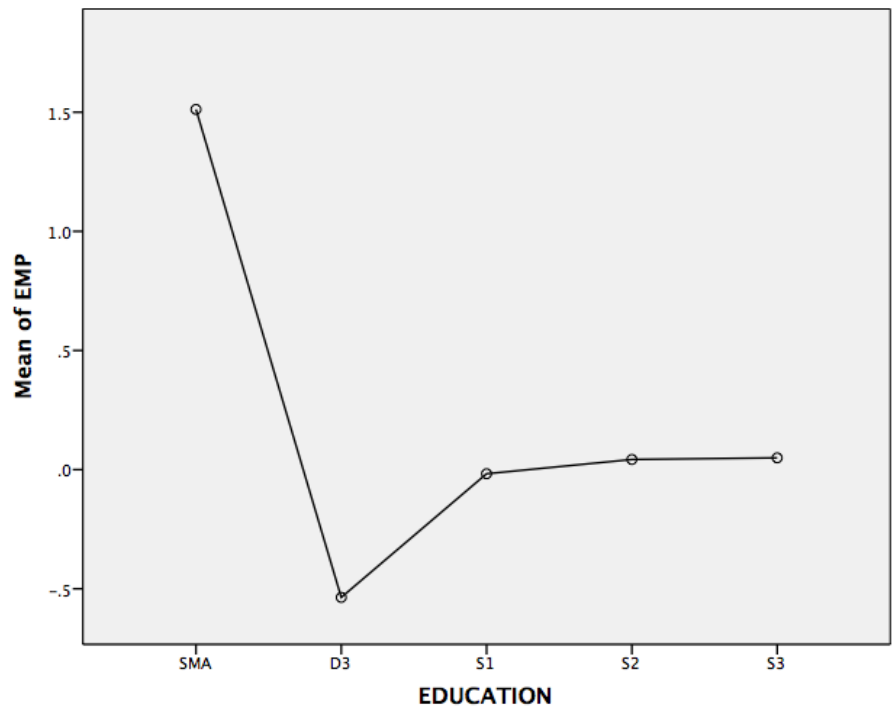

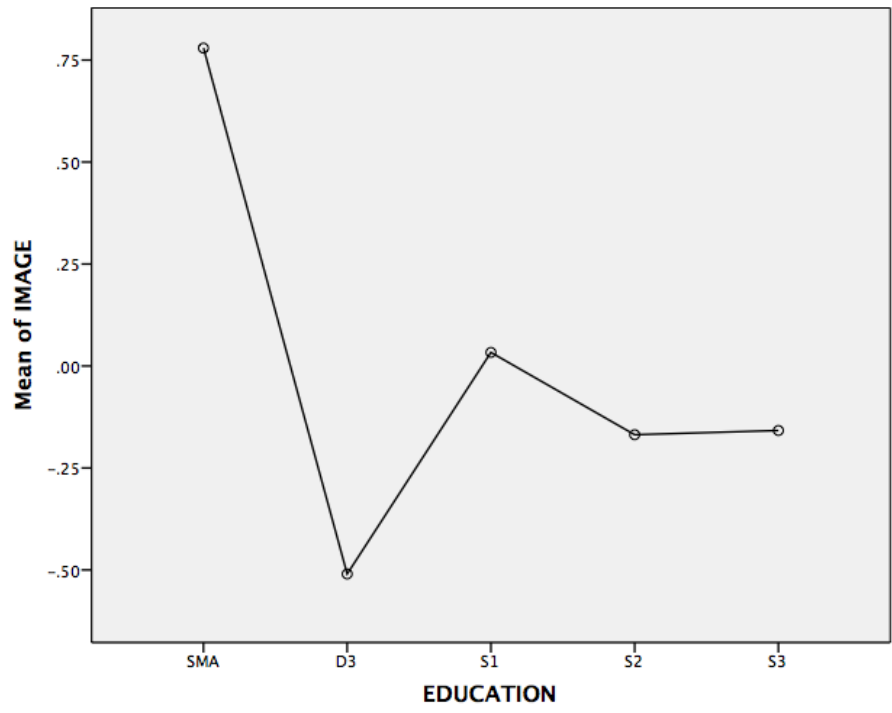
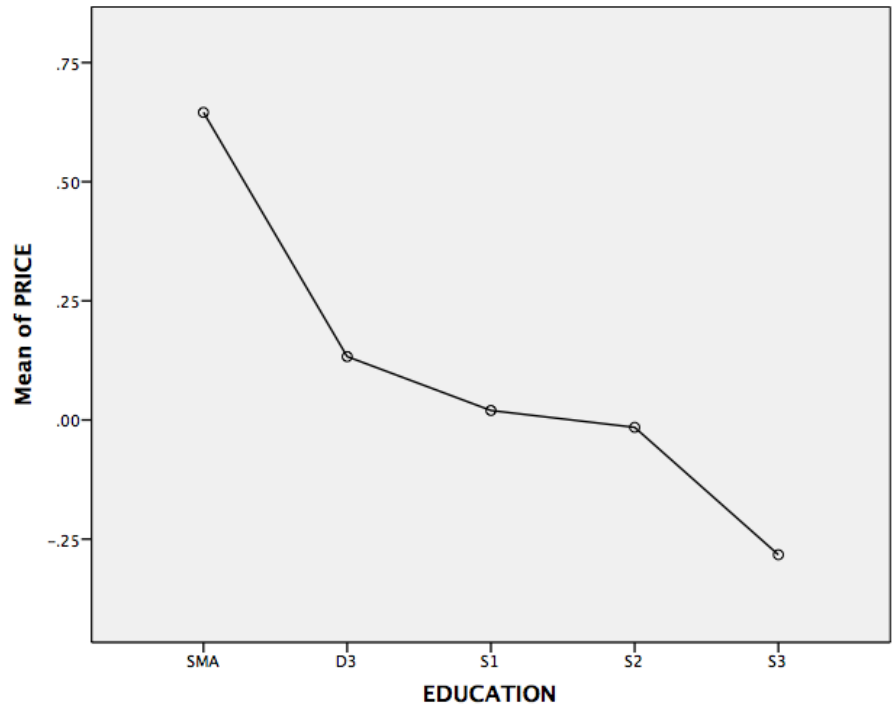

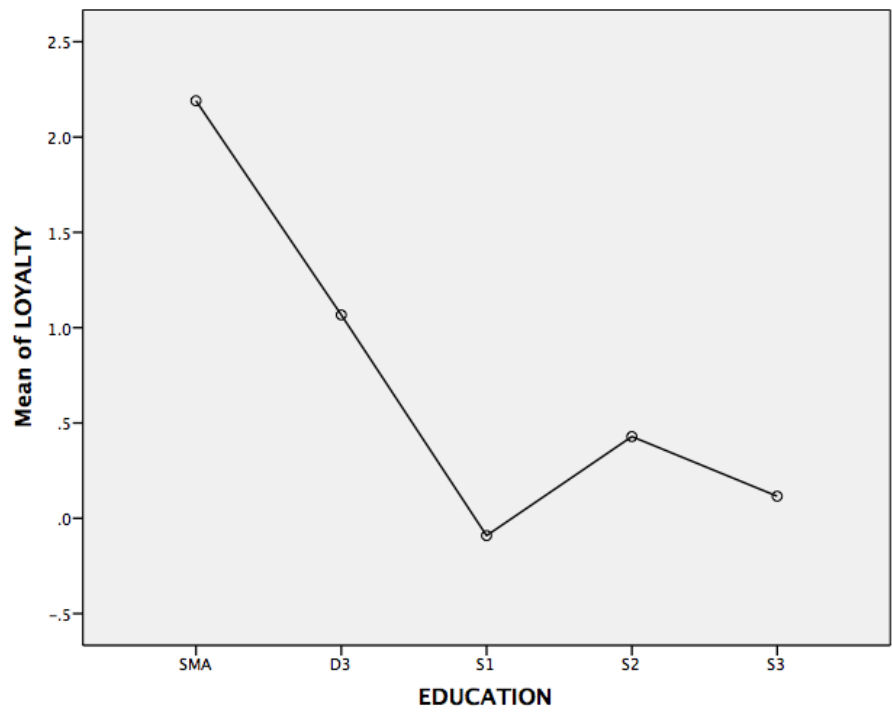
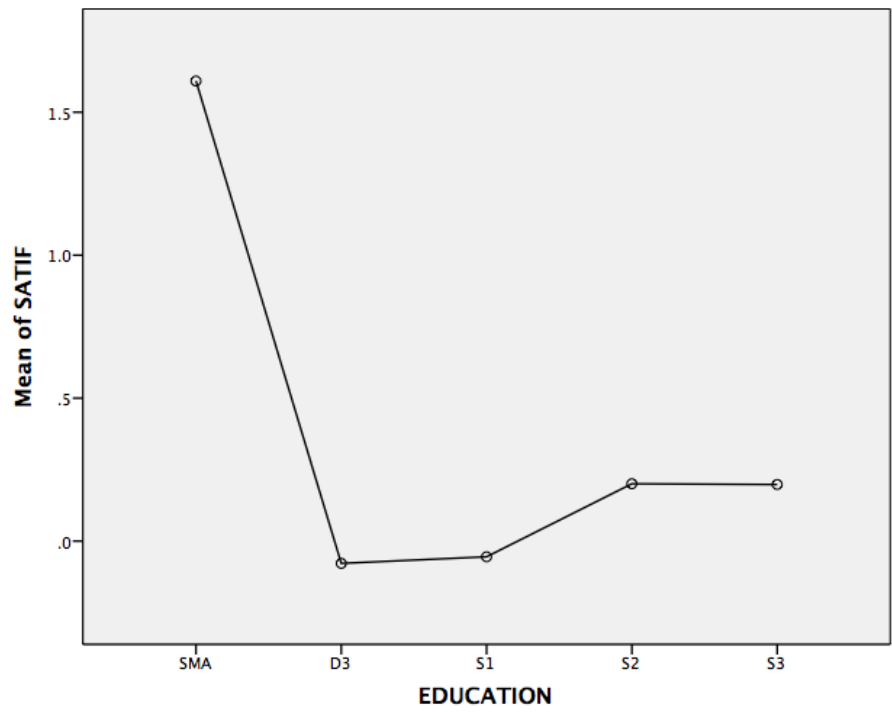

ONEWAY REAL RESS ASS EMP TAN PRICE IMAGE SATIF LOYALTY BY WORK
 /STATISTICS HOMOGENEITY
 /PLOT MEANS
 /MISSING ANALYSIS.

Oneway

Test of Homogeneity of Variances

	Levene Statistic	df1	df2	Sig.
REAL	.810	4	155	.521
RESS	1.241	4	155	.296
ASS	1.237	4	155	.298
EMP	1.477	4	155	.212
TAN	.644	4	155	.632
PRICE	.520	4	155	.721
IMAGE	1.509	4	155	.202
SATIF	.880	4	155	.477
LOYALTY	1.807	4	155	.130

ANOVA

		Sum of Squares	df	Mean Square	F	Sig.
REAL	Between Groups	3.702	4	.926	.924	.452
	Within Groups	155.298	155	1.002		
	Total	159.000	159			
RESS	Between Groups	9.042	4	2.261	2.337	.058
	Within Groups	149.958	155	.967		
	Total	159.000	159			
ASS	Between Groups	3.548	4	.887	.884	.475
	Within Groups	155.452	155	1.003		
	Total	159.000	159			
EMP	Between Groups	1.831	4	.458	.452	.771
	Within Groups	157.169	155	1.014		
	Total	159.000	159			
TAN	Between Groups	.594	4	.148	.145	.965
	Within Groups	158.406	155	1.022		
	Total	159.000	159			

		Sum of Squares	df	Mean Square	F	Sig.
PRICE	Between Groups	.887	4	.222	.217	.928
	Within Groups	158.113	155	1.020		
	Total	159.000	159			
IMAGE	Between Groups	4.810	4	1.203	1.209	.309
	Within Groups	154.190	155	.995		
	Total	159.000	159			
SATIF	Between Groups	2.005	4	.501	.495	.739
	Within Groups	156.995	155	1.013		
	Total	159.000	159			
LOYALTY	Between Groups	5.890	4	1.472	1.491	.208
	Within Groups	153.110	155	.988		
	Total	159.000	159			

Means Plots

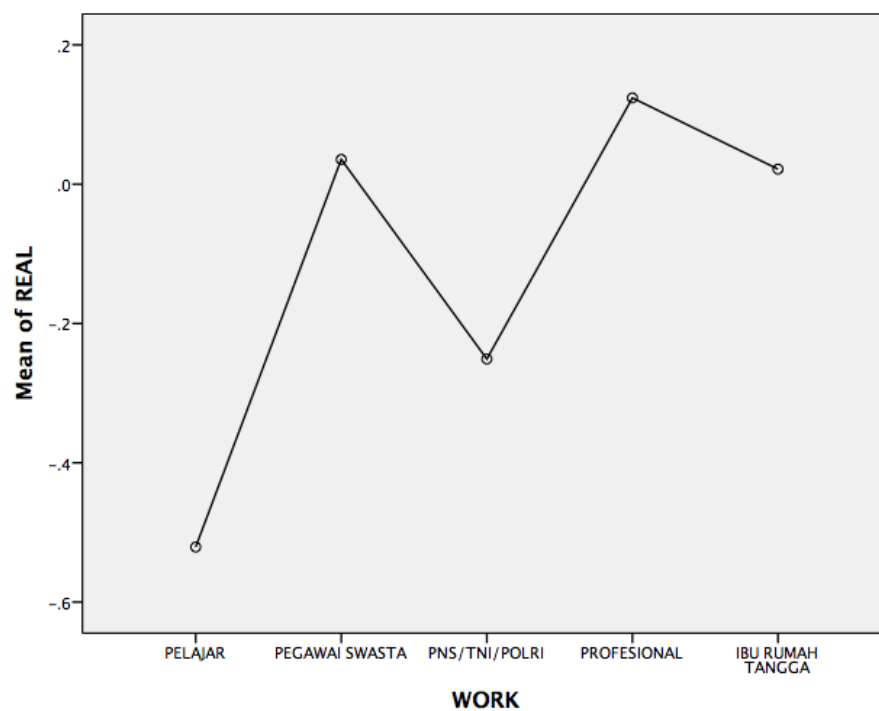

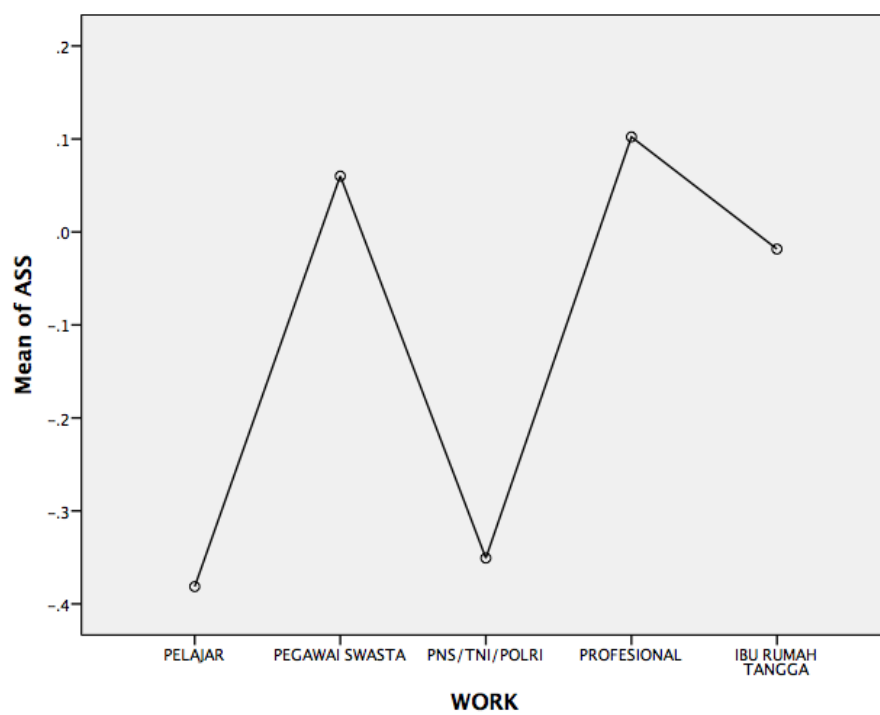
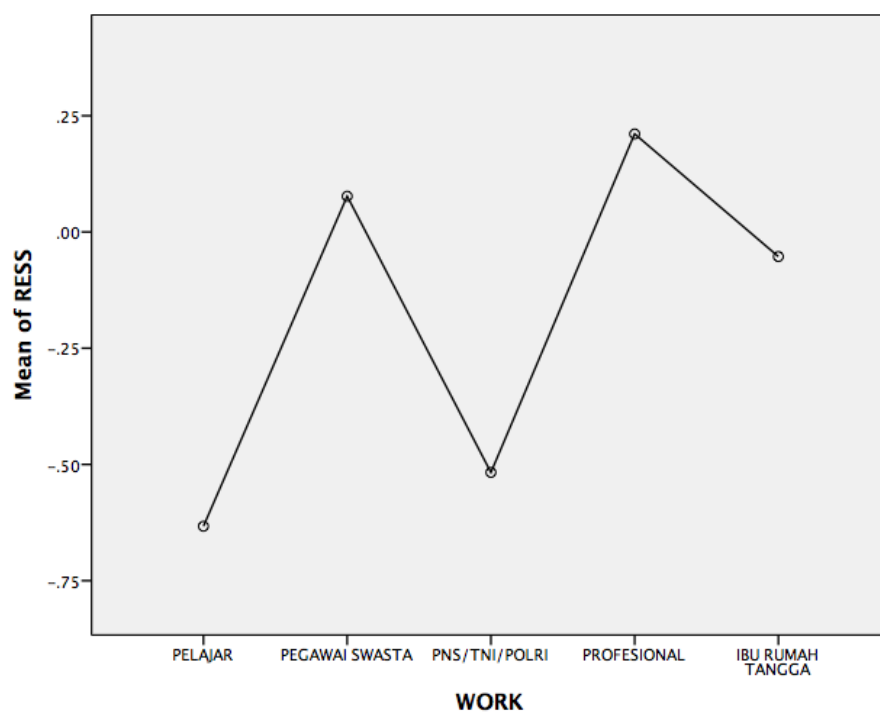

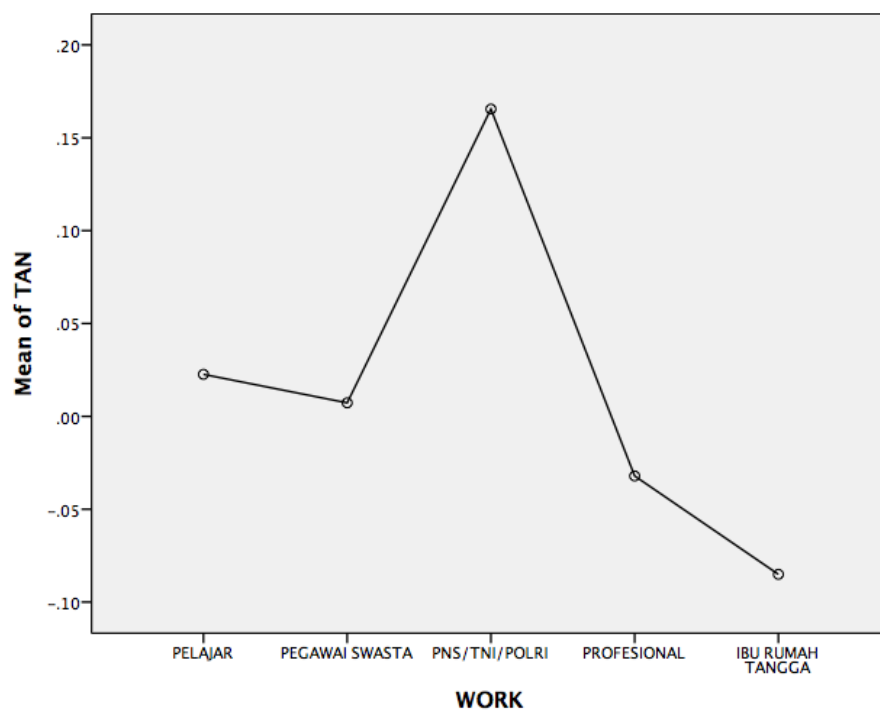
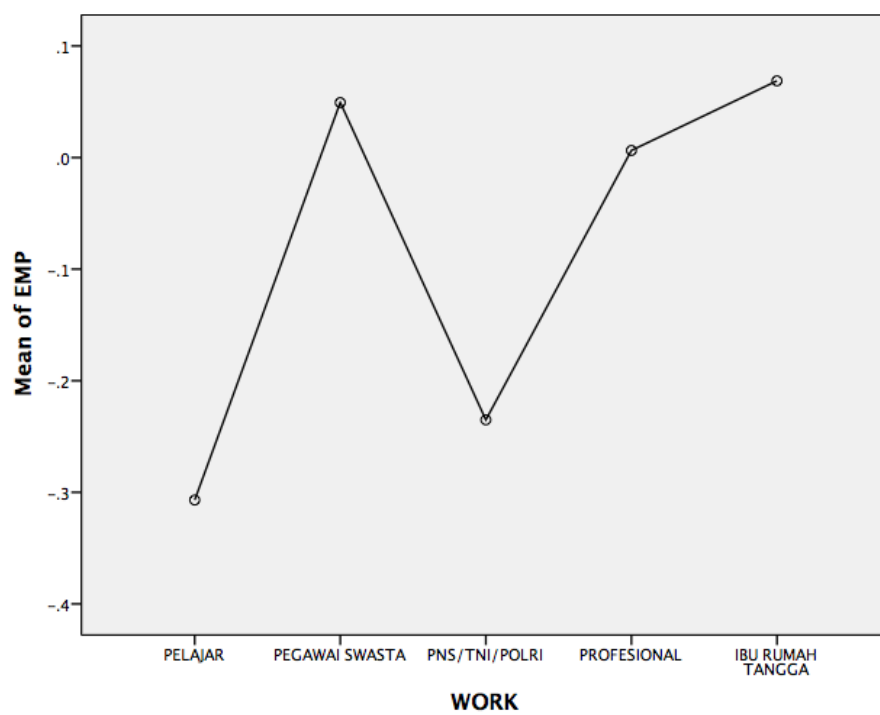

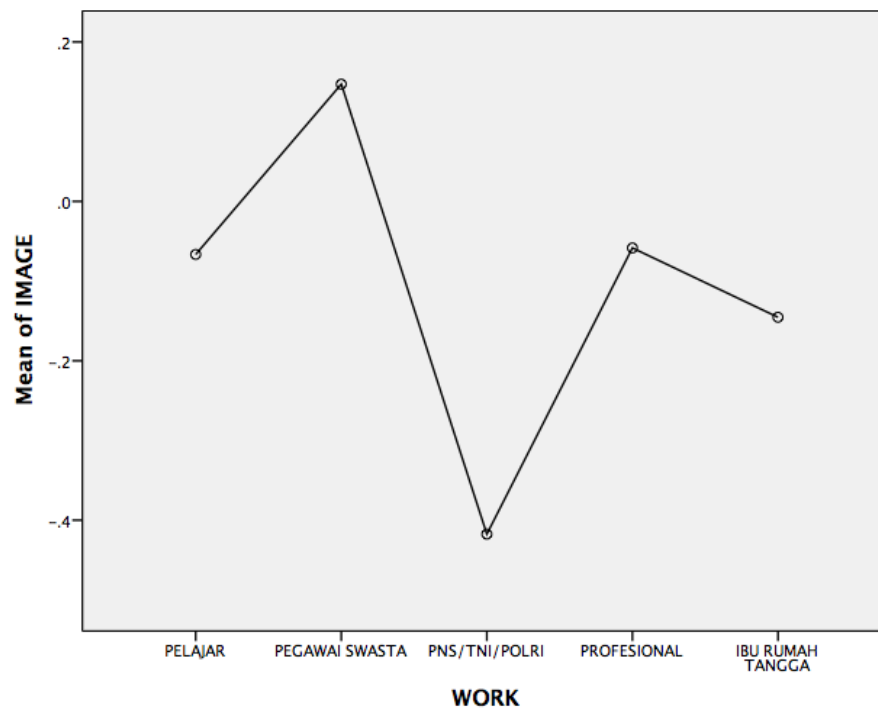
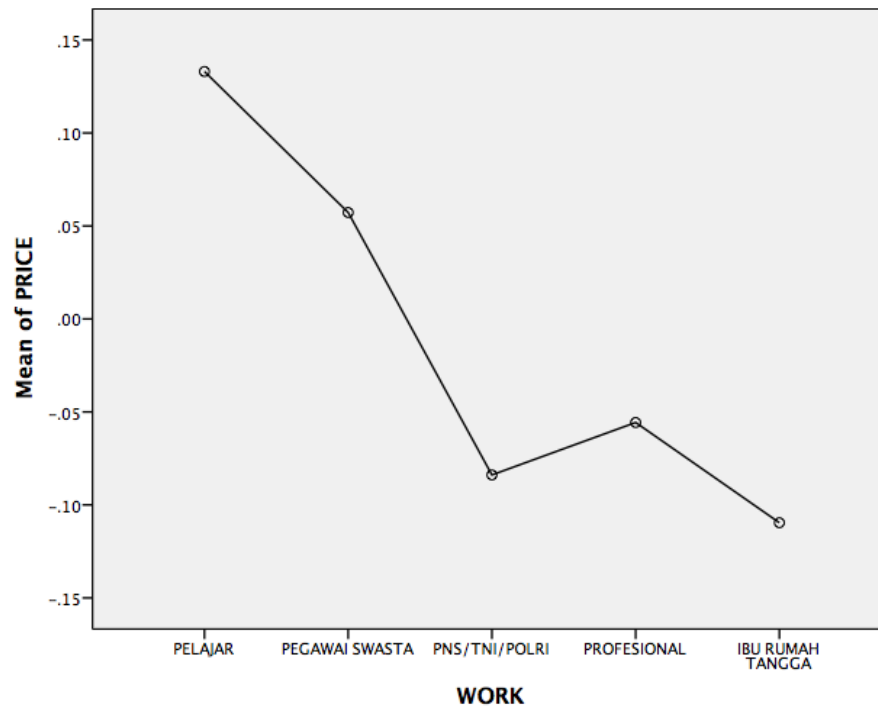

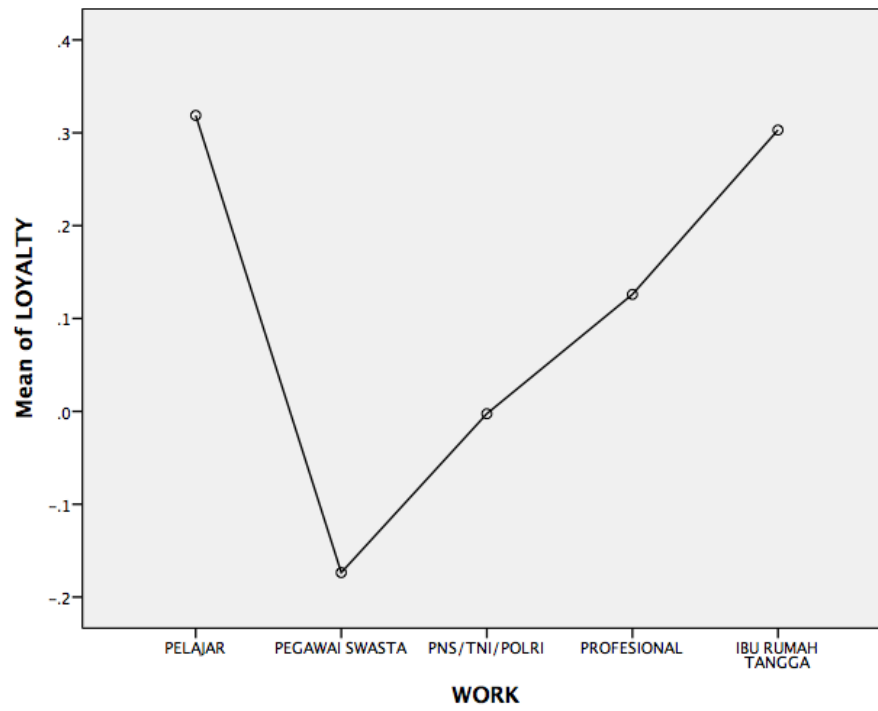
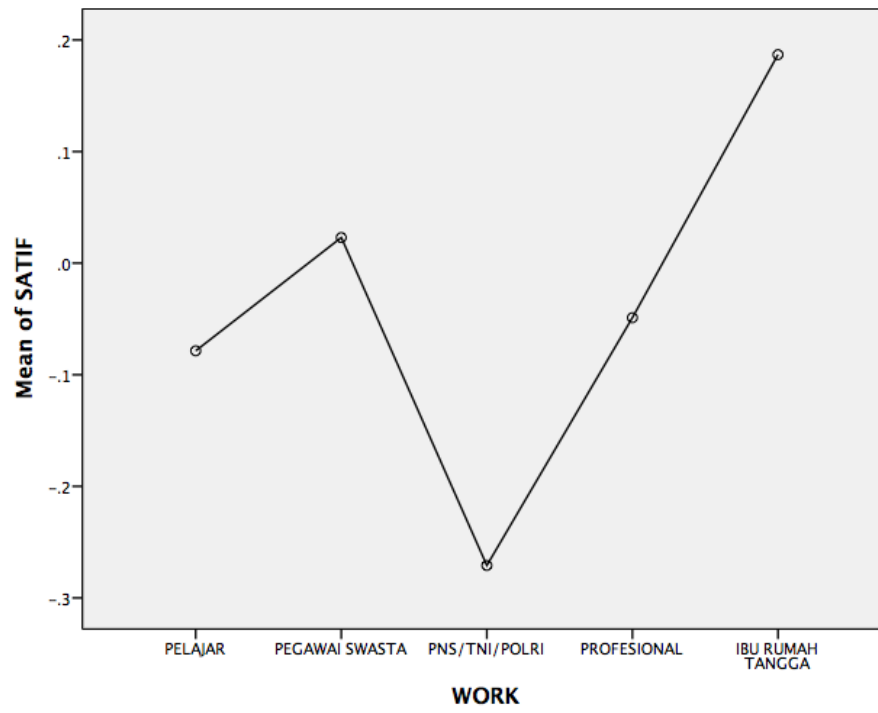

ONEWAY REAL RESS ASS EMP TAN PRICE IMAGE SATIF LOYALTY BY OUT.P
 /STATISTICS HOMOGENEITY
 /PLOT MEANS
 /MISSING ANALYSIS.

Oneway

Test of Homogeneity of Variances

	Levene Statistic	df1	df2	Sig.
REAL	.035	1	158	.851
RESS	1.613	1	158	.206
ASS	.776	1	158	.380
EMP	.024	1	158	.877
TAN	3.299	1	158	.071
PRICE	.087	1	158	.769
IMAGE	.268	1	158	.605
SATIF	.049	1	158	.826
LOYALTY	.190	1	158	.664

ANOVA

		Sum of Squares	df	Mean Square	F	Sig.
REAL	Between Groups	.032	1	.032	.031	.859
	Within Groups	158.968	158	1.006		
	Total	159.000	159			
RESS	Between Groups	1.137	1	1.137	1.138	.288
	Within Groups	157.863	158	.999		
	Total	159.000	159			
ASS	Between Groups	.154	1	.154	.153	.696
	Within Groups	158.846	158	1.005		
	Total	159.000	159			
EMP	Between Groups	.081	1	.081	.080	.777
	Within Groups	158.919	158	1.006		
	Total	159.000	159			
TAN	Between Groups	.184	1	.184	.183	.669
	Within Groups	158.816	158	1.005		
	Total	159.000	159			

		Sum of Squares	df	Mean Square	F	Sig.
PRICE	Between Groups	.417	1	.417	.416	.520
	Within Groups	158.583	158	1.004		
	Total	159.000	159			
IMAGE	Between Groups	.090	1	.090	.089	.765
	Within Groups	158.910	158	1.006		
	Total	159.000	159			
SATIF	Between Groups	.241	1	.241	.239	.625
	Within Groups	158.759	158	1.005		
	Total	159.000	159			
LOYALTY	Between Groups	.801	1	.801	.800	.372
	Within Groups	158.199	158	1.001		
	Total	159.000	159			

Means Plots

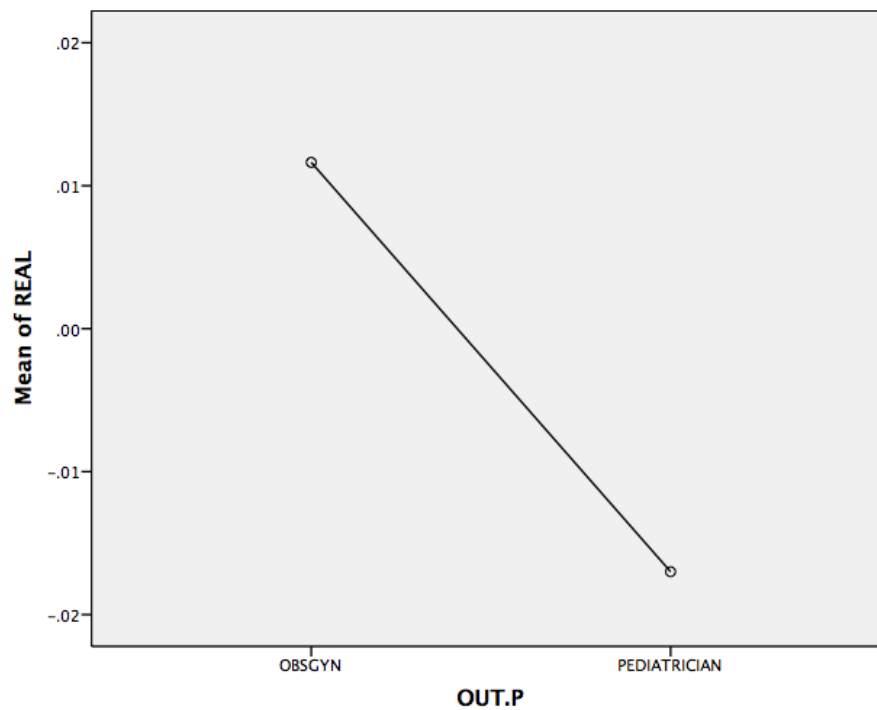

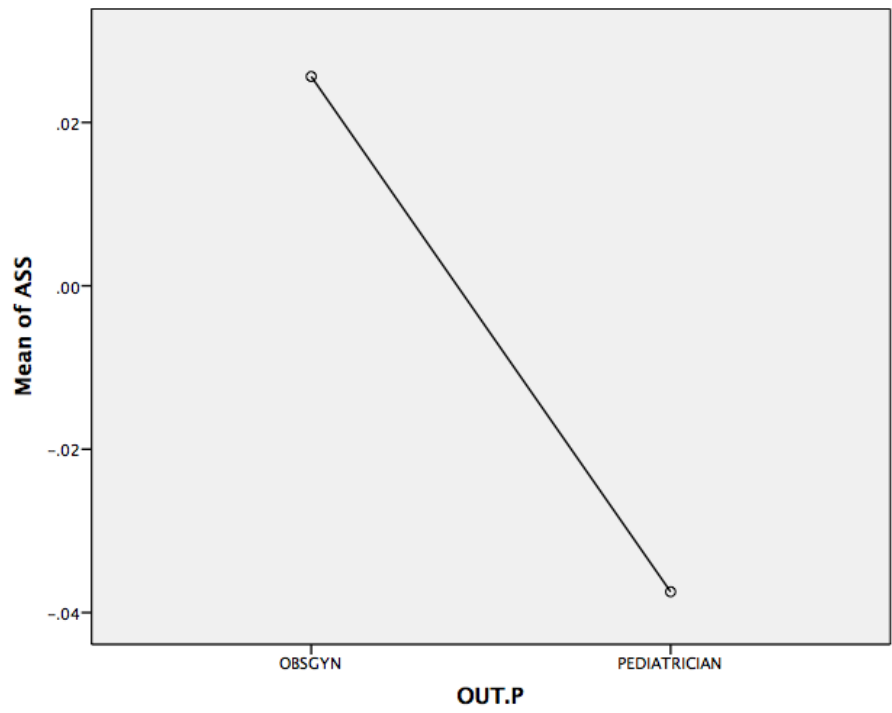
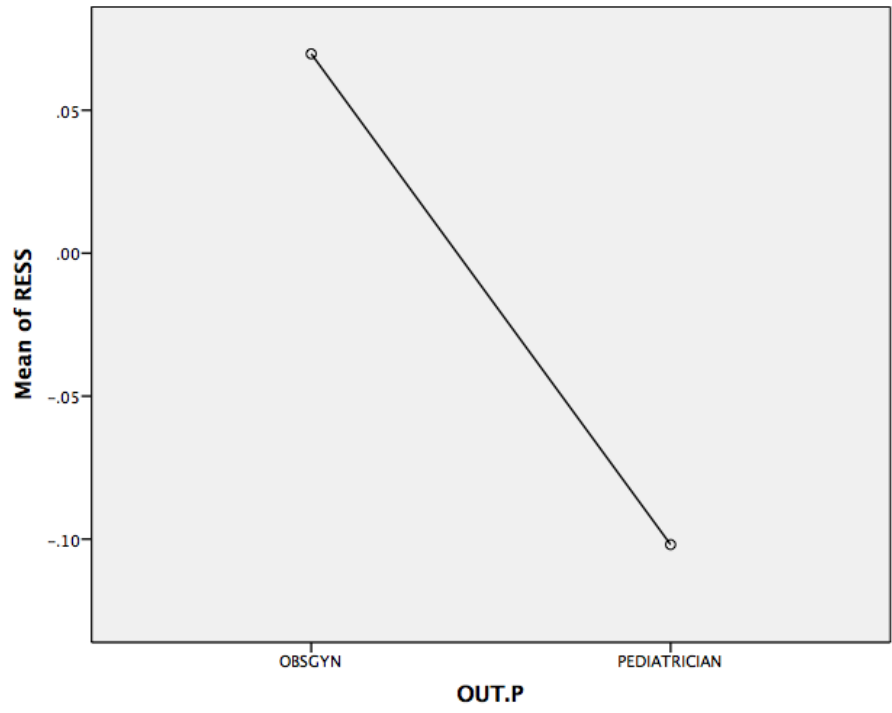

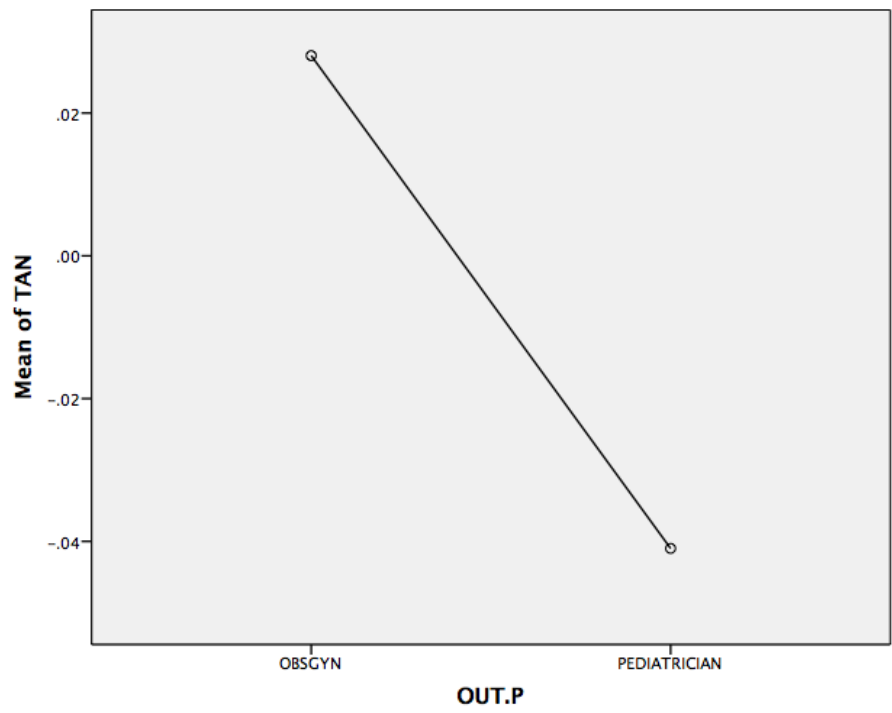
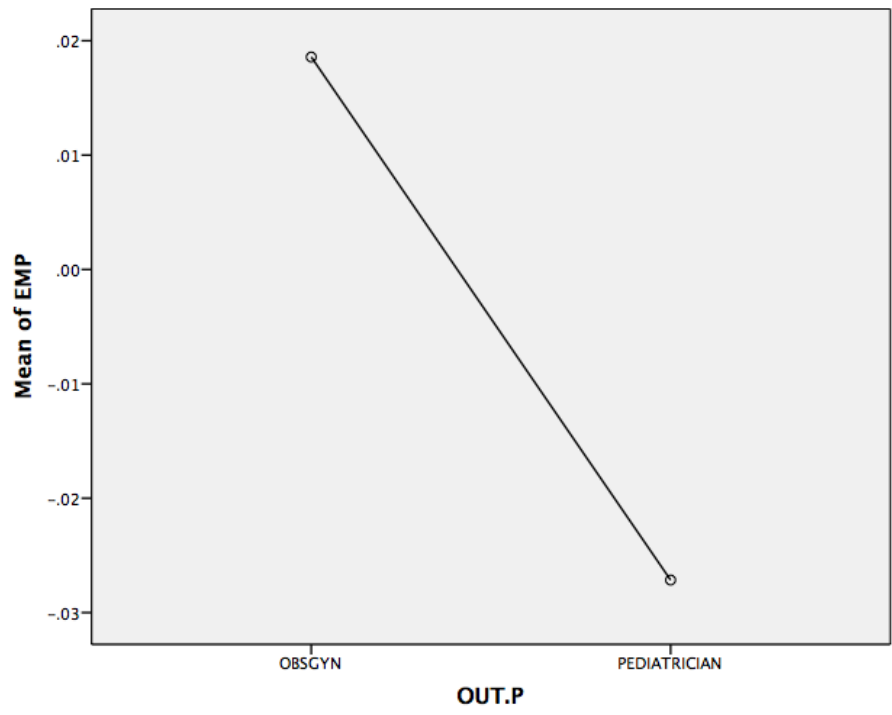

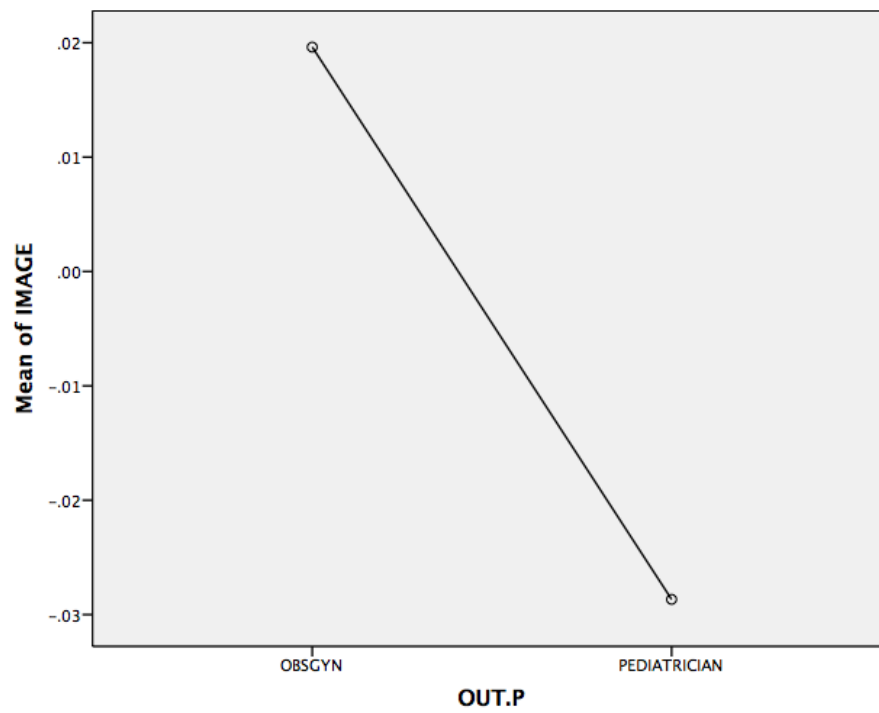
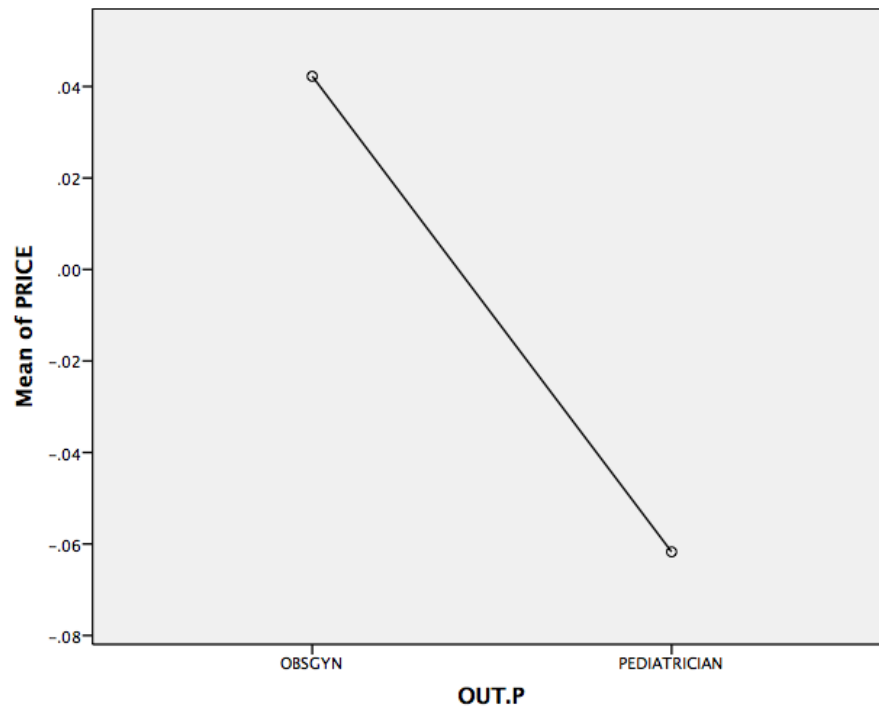

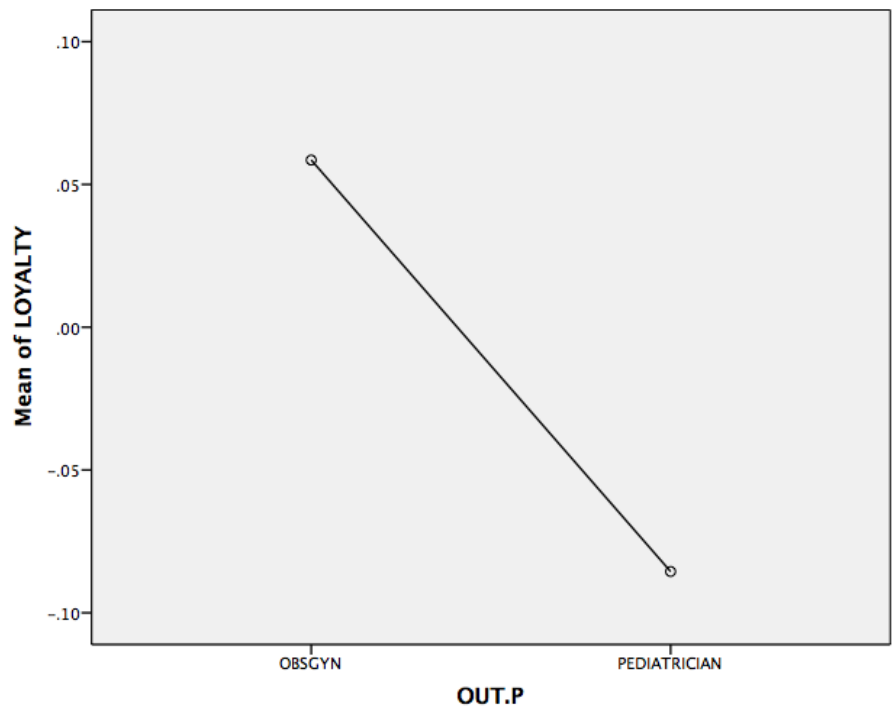
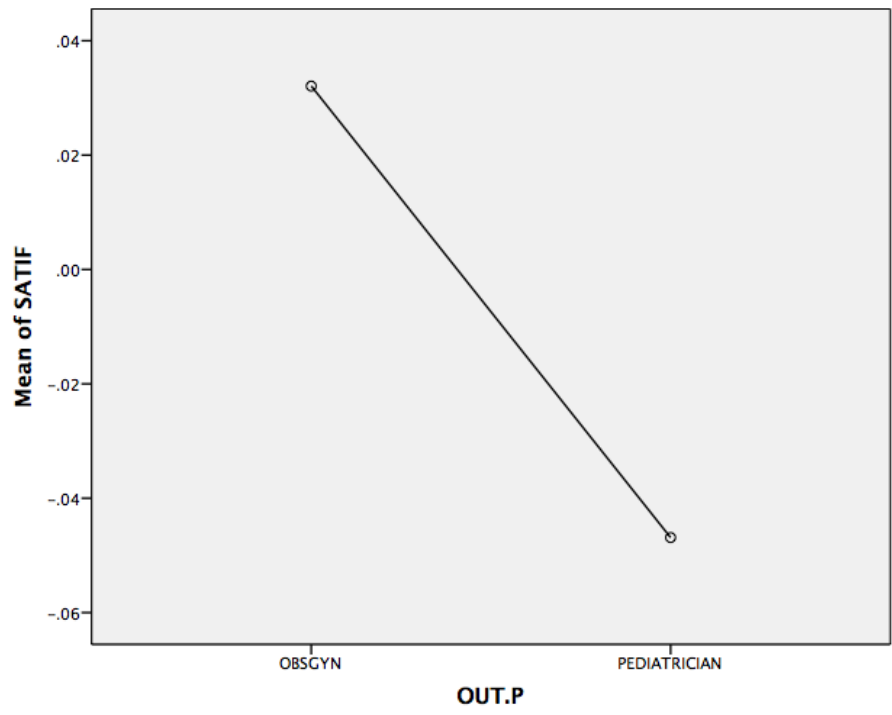

ONEWAY REAL RESS ASS EMP TAN PRICE IMAGE SATIF LOYALTY BY FREKUENSI
 /STATISTICS HOMOGENEITY
 /PLOT MEANS
 /MISSING ANALYSIS.

Oneway

Test of Homogeneity of Variances

	Levene Statistic	df1	df2	Sig.
REAL	.378	1	158	.540
RESS	.149	1	158	.700
ASS	.001	1	158	.972
EMP	.889	1	158	.347
TAN	.306	1	158	.581
PRICE	.000	1	158	.986
IMAGE	.252	1	158	.616
SATIF	.022	1	158	.881
LOYALTY	1.736	1	158	.190

ANOVA

		Sum of Squares	df	Mean Square	F	Sig.
REAL	Between Groups	.511	1	.511	.510	.476
	Within Groups	158.489	158	1.003		
	Total	159.000	159			
RESS	Between Groups	.629	1	.629	.628	.429
	Within Groups	158.371	158	1.002		
	Total	159.000	159			
ASS	Between Groups	.556	1	.556	.555	.457
	Within Groups	158.444	158	1.003		
	Total	159.000	159			
EMP	Between Groups	.015	1	.015	.015	.903
	Within Groups	158.985	158	1.006		
	Total	159.000	159			
TAN	Between Groups	.784	1	.784	.783	.378
	Within Groups	158.216	158	1.001		
	Total	159.000	159			

		Sum of Squares	df	Mean Square	F	Sig.
PRICE	Between Groups	.116	1	.116	.115	.735
	Within Groups	158.884	158	1.006		
	Total	159.000	159			
IMAGE	Between Groups	.912	1	.912	.912	.341
	Within Groups	158.088	158	1.001		
	Total	159.000	159			
SATIF	Between Groups	.007	1	.007	.007	.933
	Within Groups	158.993	158	1.006		
	Total	159.000	159			
LOYALTY	Between Groups	1.517	1	1.517	1.522	.219
	Within Groups	157.483	158	.997		
	Total	159.000	159			

Means Plots

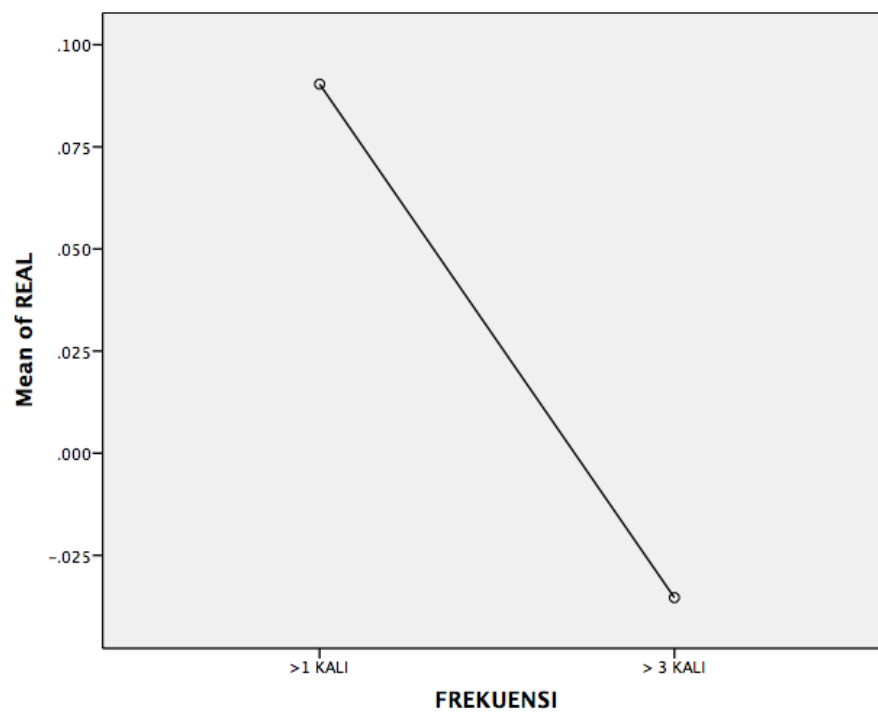

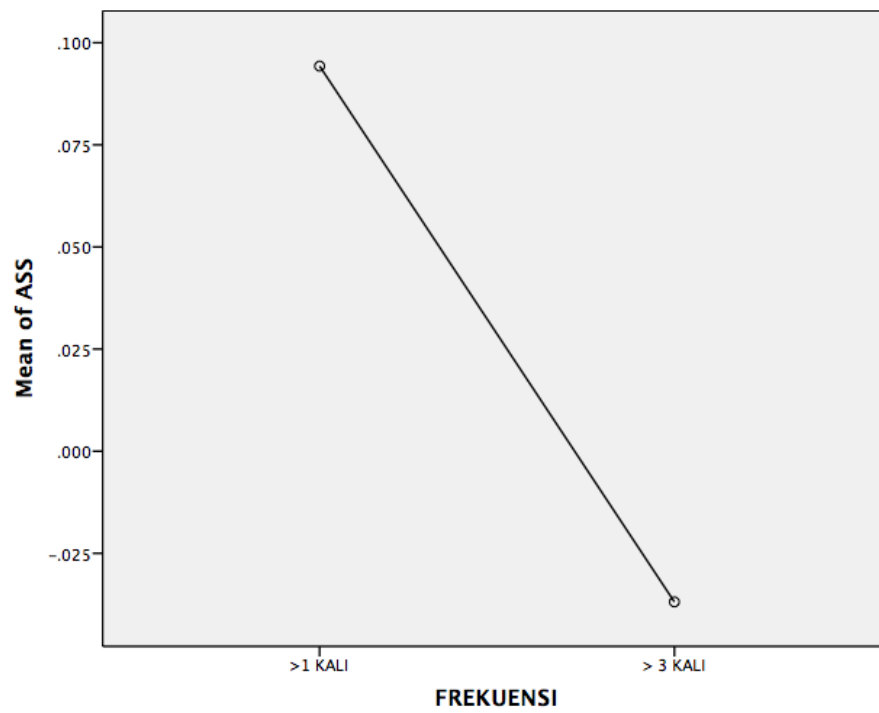
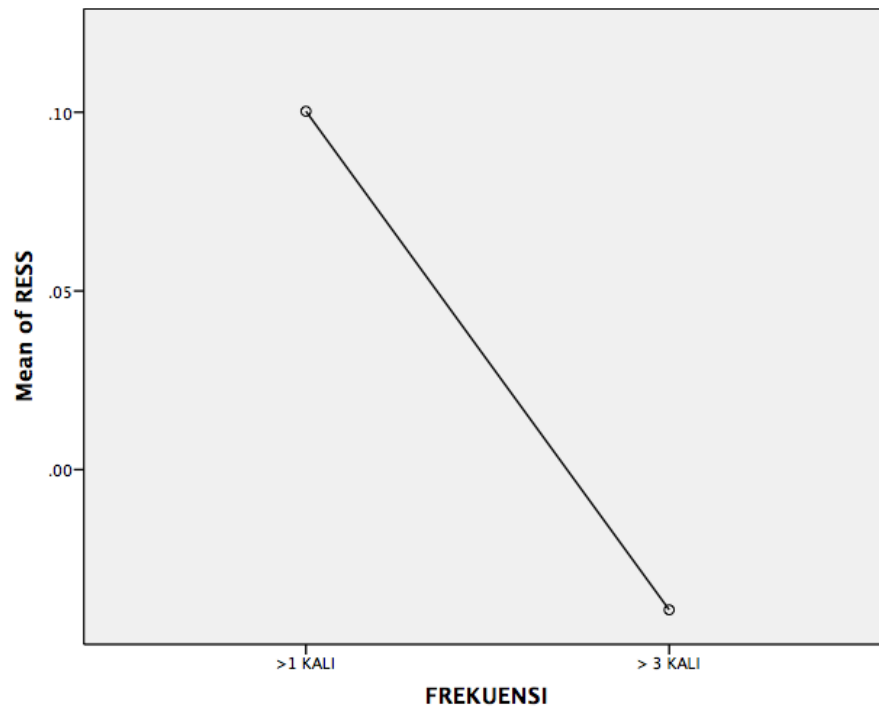

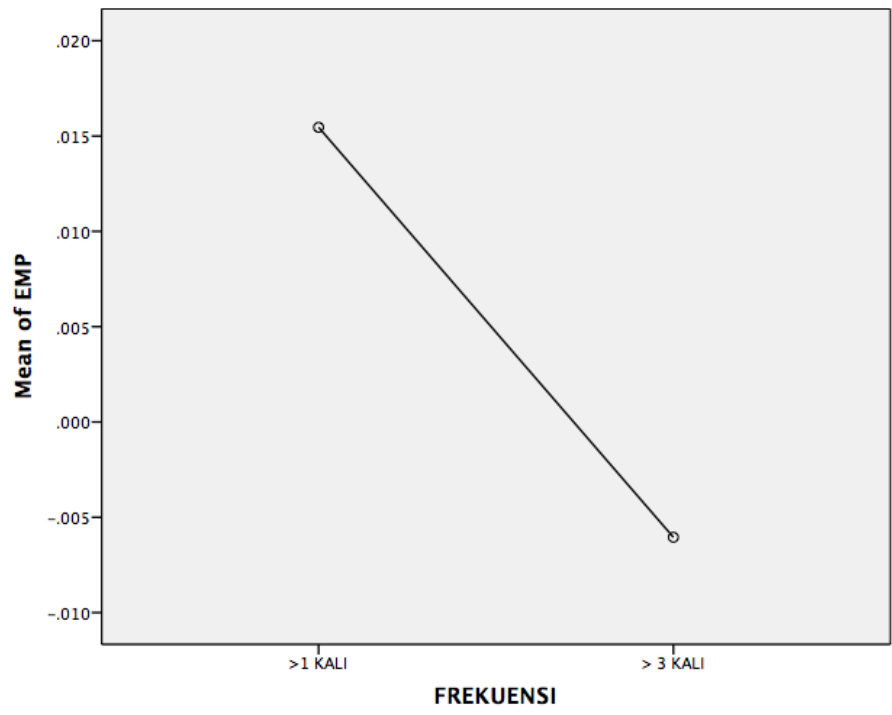

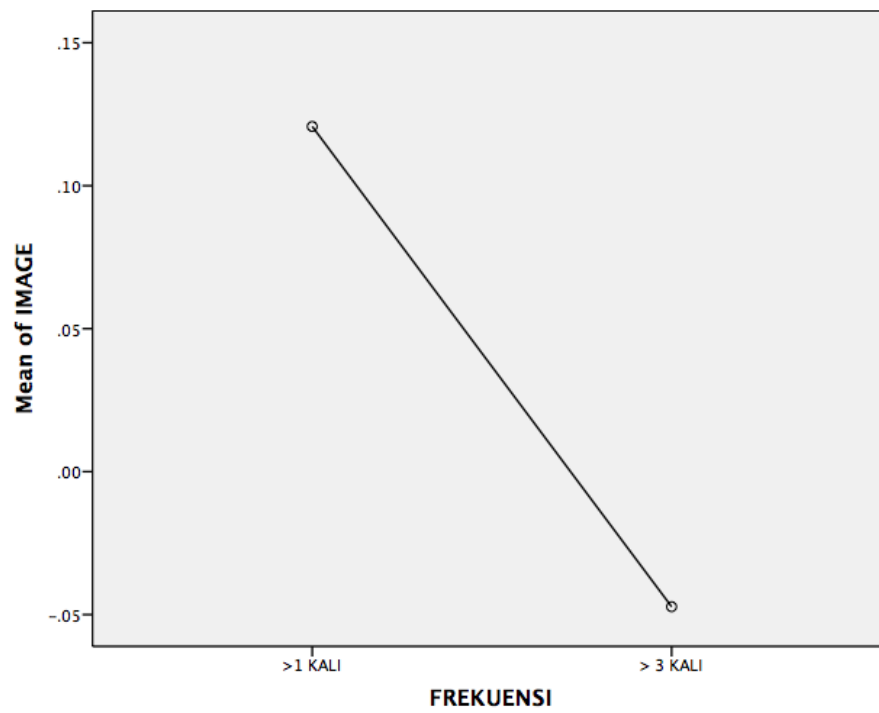
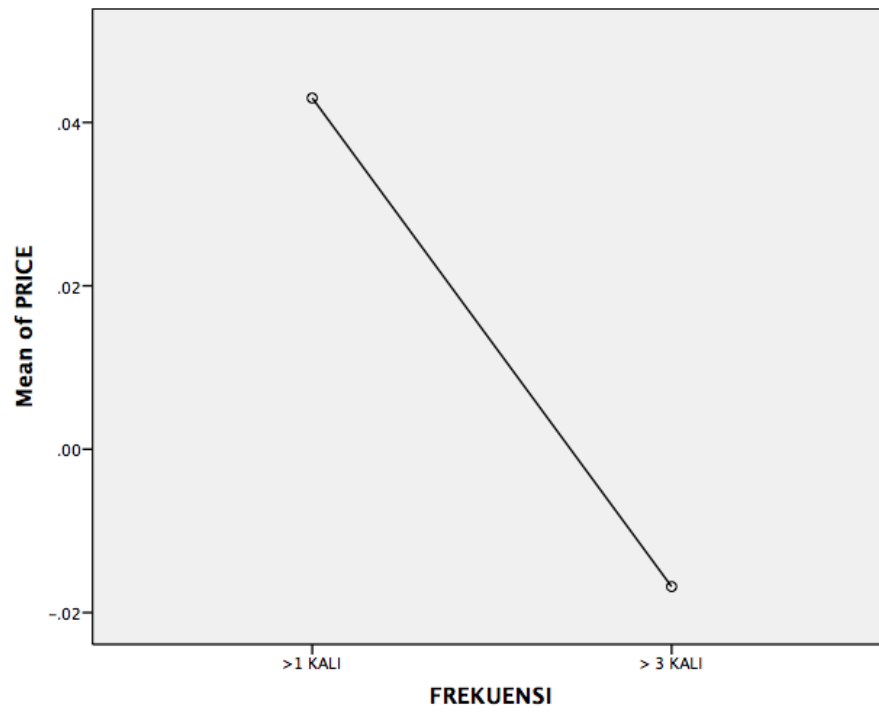

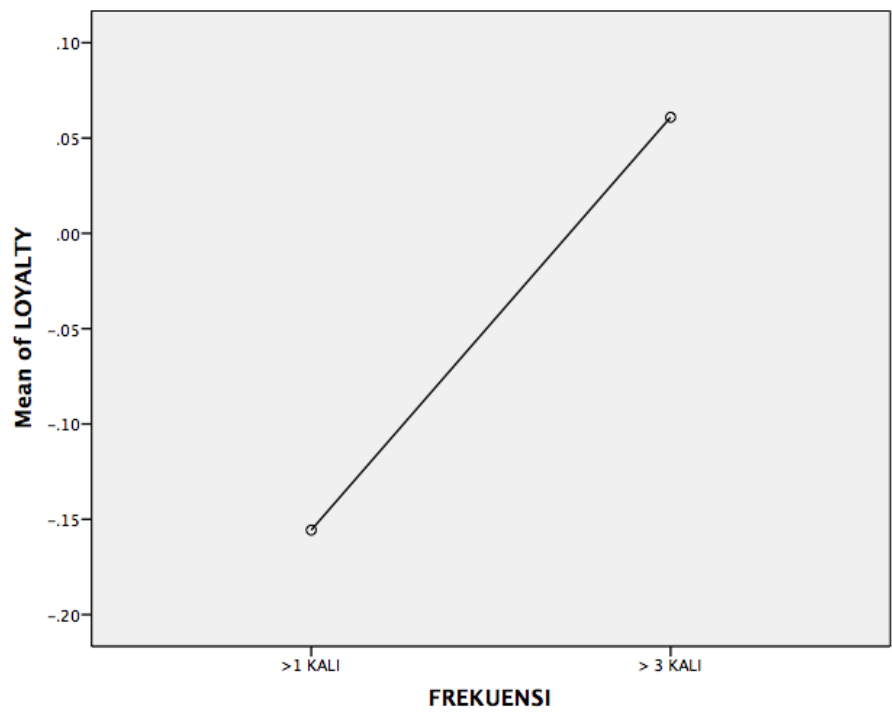
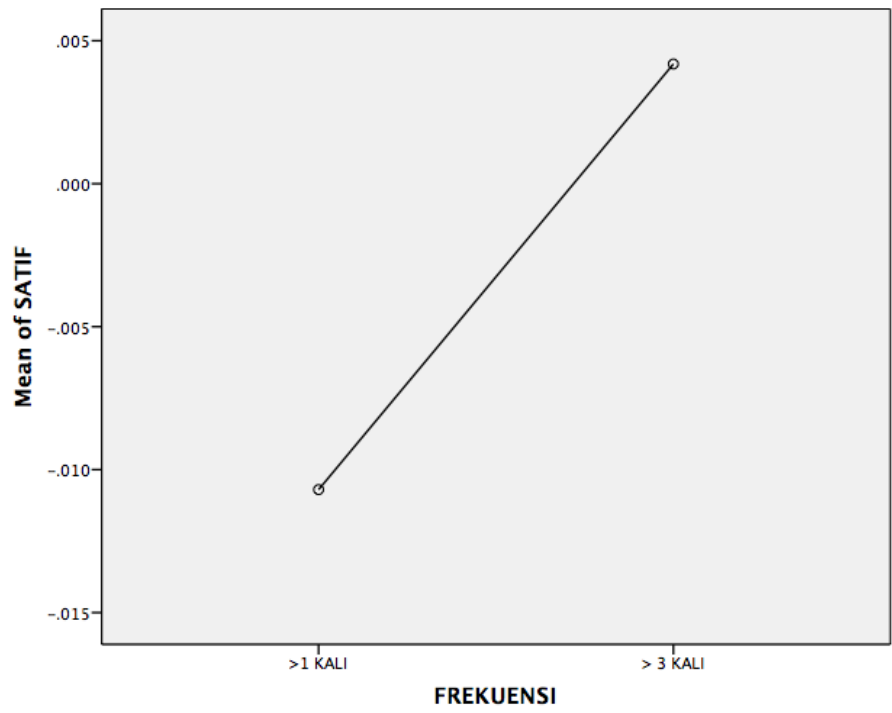

ONEWAY REAL RESS ASS EMP TAN PRICE IMAGE SATIF LOYALTY BY AGE
 /STATISTICS HOMOGENEITY
 /PLOT MEANS
 /MISSING ANALYSIS.

Oneway

Test of Homogeneity of Variances

	Levene Statistic	df1	df2	Sig.
REAL	.748	3	156	.525
RESS	.040	3	156	.989
ASS	.366	3	156	.778
EMP	.323	3	156	.809
TAN	.140	3	156	.936
PRICE	1.232	3	156	.300
IMAGE	.763	3	156	.517
SATIF	.451	3	156	.717
LOYALTY	2.059	3	156	.108

ANOVA

		Sum of Squares	df	Mean Square	F	Sig.
REAL	Between Groups	1.792	3	.597	.593	.621
	Within Groups	157.208	156	1.008		
	Total	159.000	159			
RESS	Between Groups	2.410	3	.803	.800	.495
	Within Groups	156.590	156	1.004		
	Total	159.000	159			
ASS	Between Groups	2.431	3	.810	.807	.492
	Within Groups	156.569	156	1.004		
	Total	159.000	159			
EMP	Between Groups	2.742	3	.914	.913	.436
	Within Groups	156.258	156	1.002		
	Total	159.000	159			
TAN	Between Groups	1.099	3	.366	.362	.781
	Within Groups	157.901	156	1.012		
	Total	159.000	159			

		Sum of Squares	df	Mean Square	F	Sig.
PRICE	Between Groups	3.188	3	1.063	1.064	.366
	Within Groups	155.812	156	.999		
	Total	159.000	159			
IMAGE	Between Groups	4.109	3	1.370	1.380	.251
	Within Groups	154.891	156	.993		
	Total	159.000	159			
SATIF	Between Groups	.627	3	.209	.206	.892
	Within Groups	158.373	156	1.015		
	Total	159.000	159			
LOYALTY	Between Groups	.828	3	.276	.272	.845
	Within Groups	158.172	156	1.014		
	Total	159.000	159			

Means Plots

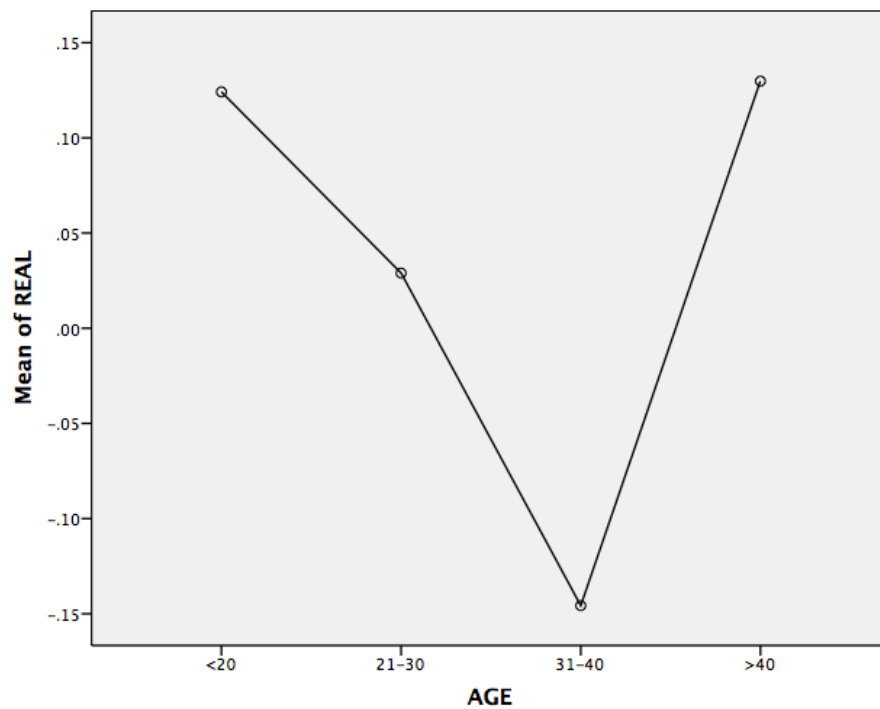

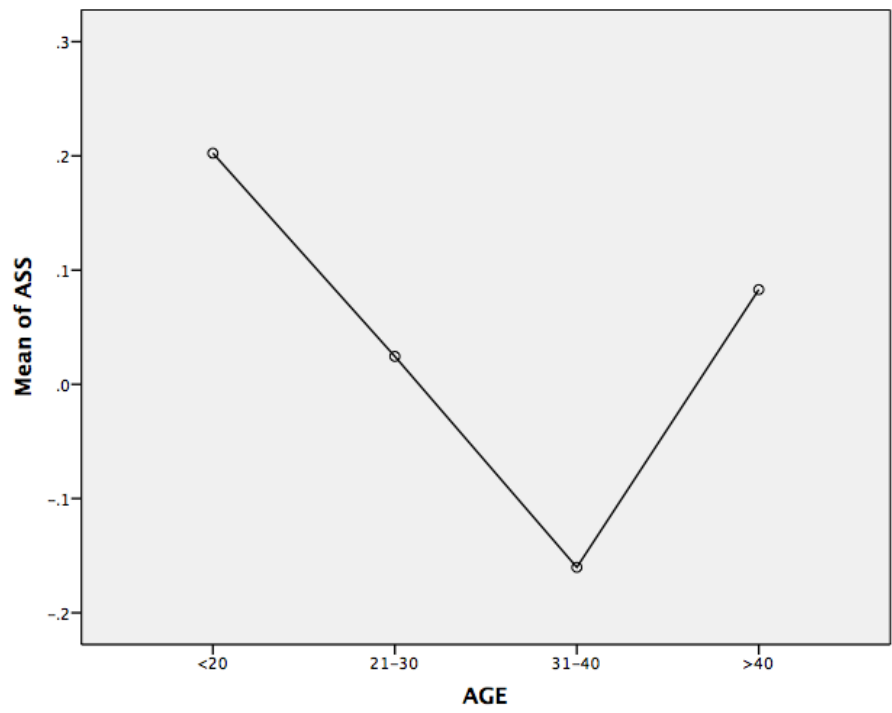
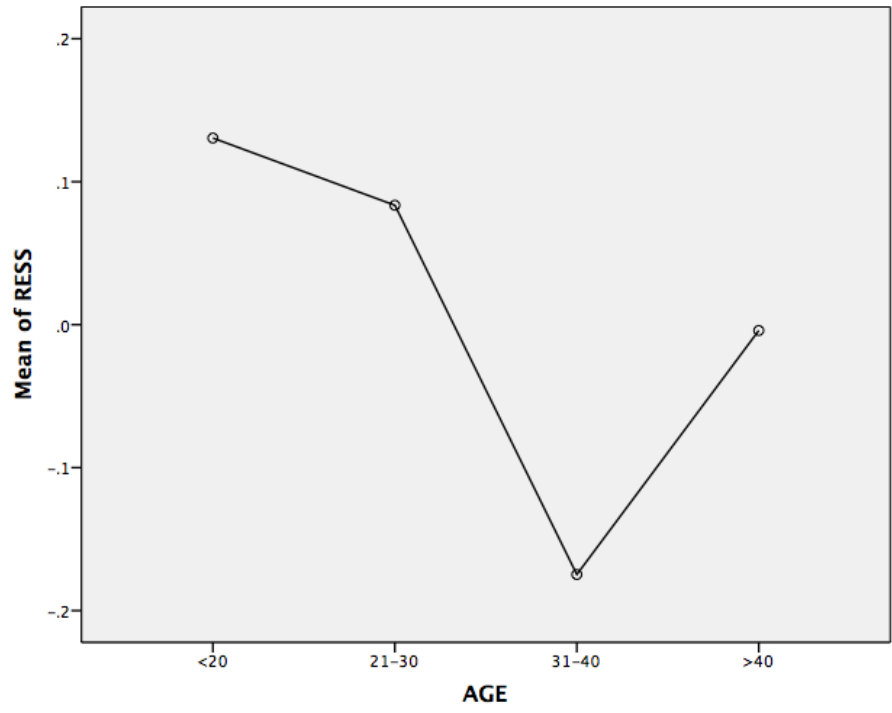

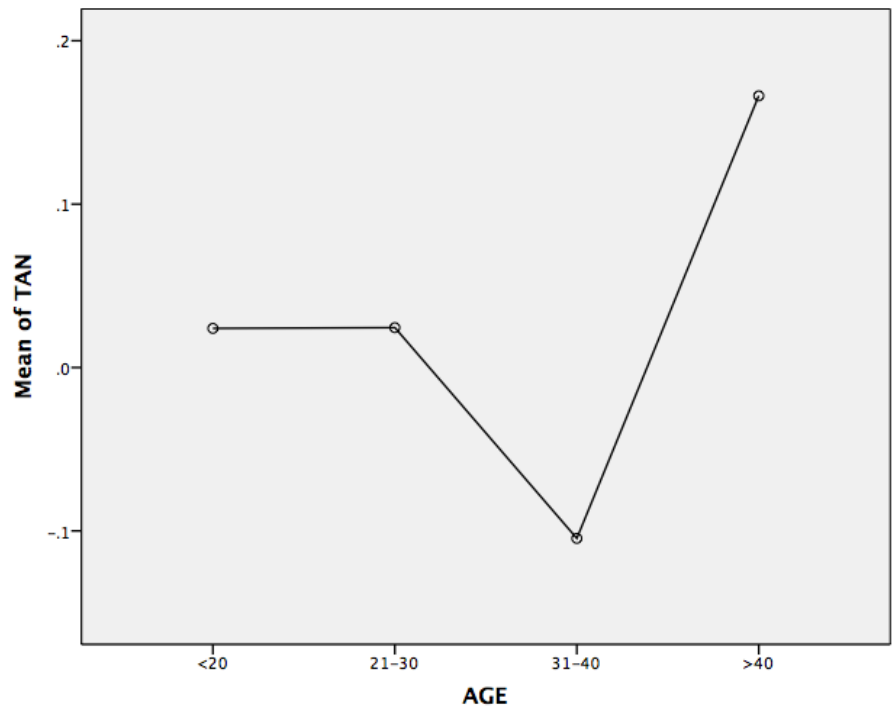
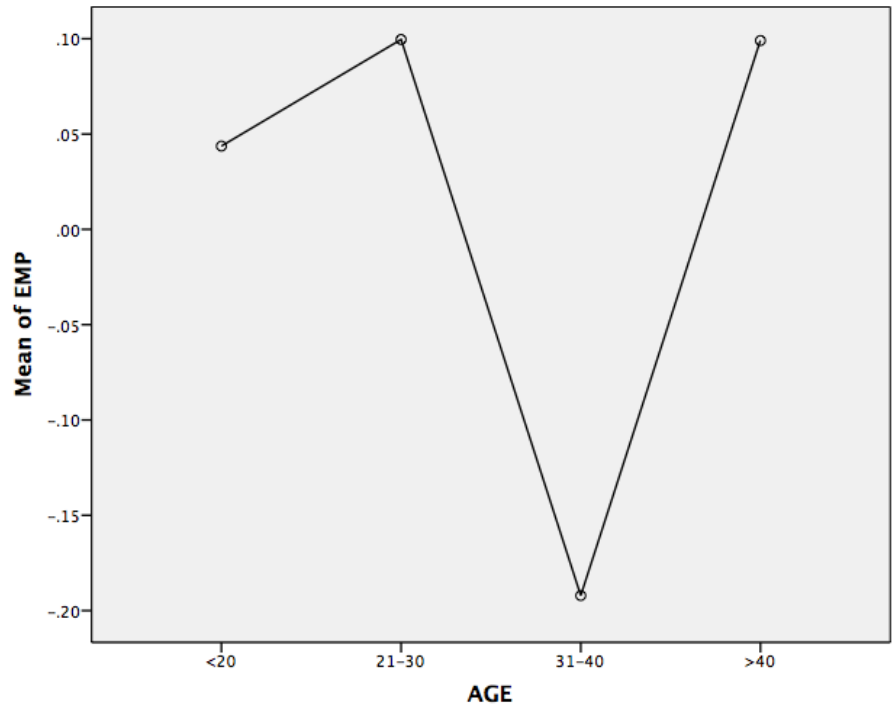

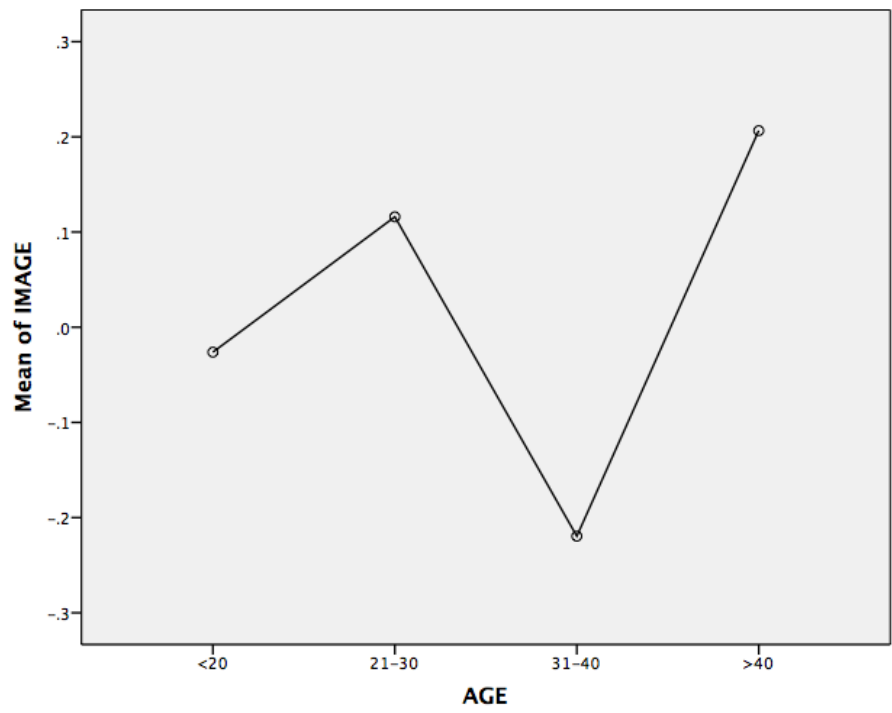
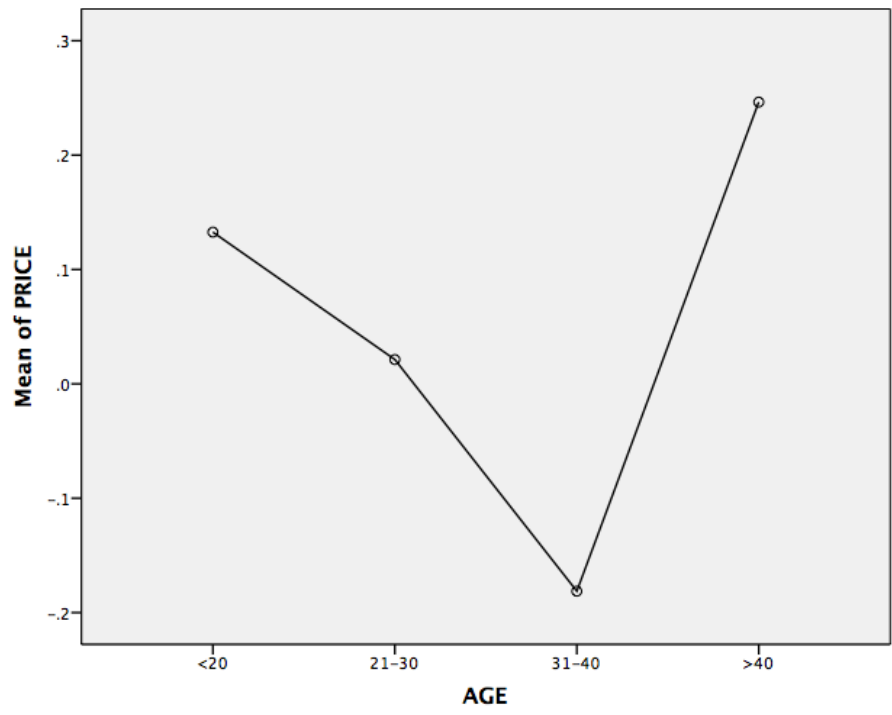

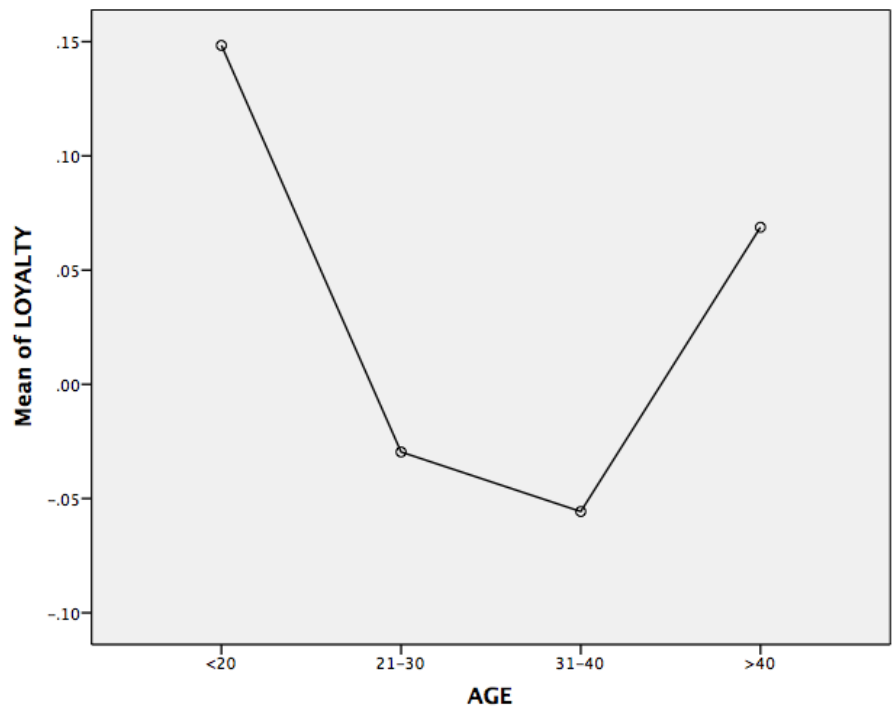
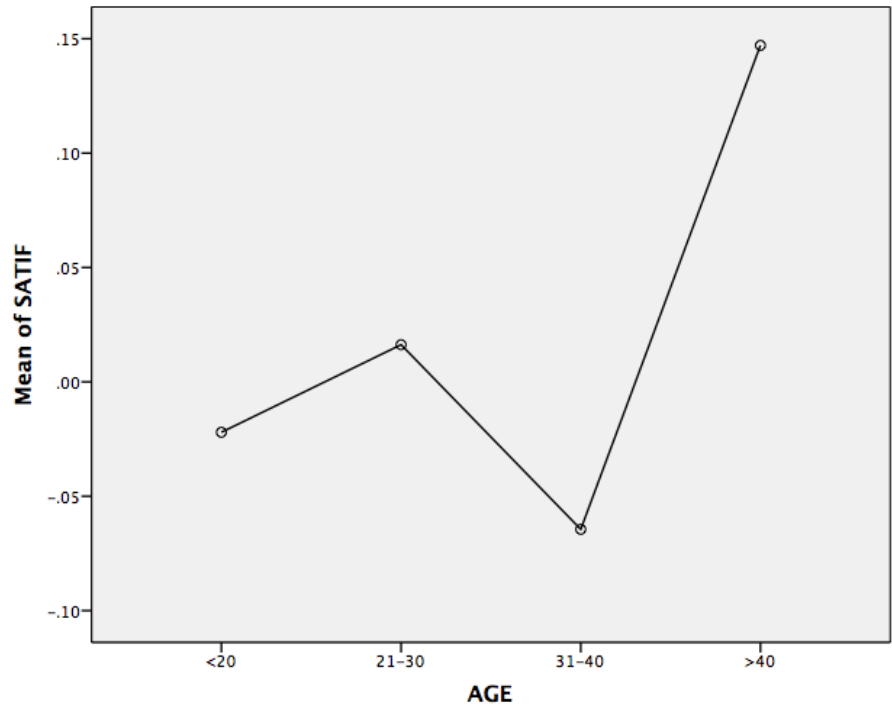

Lampiran 10
Output SPSS ver 22, Uji ANOVA

ONEWAY REAL RESS ASS EMP TAN PRICE IMAGE SATIF LOYALTY BY GENDER
/STATISTICS HOMOGENEITY
/PLOT MEANS
/MISSING ANALYSIS.

Oneway

Test of Homogeneity of Variances

	Levene Statistic	df1	df2	Sig.
REAL	.513	1	158	.475
RESS	.341	1	158	.560
ASS	.310	1	158	.579
EMP	.021	1	158	.885
TAN	1.507	1	158	.221
PRICE	.250	1	158	.618
IMAGE	.598	1	158	.441
SATIF	.506	1	158	.478
LOYALTY	.769	1	158	.382

ANOVA

		Sum of Squares	df	Mean Square	F	Sig.
REAL	Between Groups	3.894	1	3.894	3.967	.048
	Within Groups	155.106	158	.982		
	Total	159.000	159			
RESS	Between Groups	2.970	1	2.970	3.008	.085
	Within Groups	156.030	158	.988		
	Total	159.000	159			

		Sum of Squares	df	Mean Square	F	Sig.
ASS	Between Groups	2.583	1	2.583	2.609	.108
	Within Groups	156.417	158	.990		
	Total	159.000	159			
EMP	Between Groups	1.085	1	1.085	1.086	.299
	Within Groups	157.915	158	.999		
	Total	159.000	159			
TAN	Between Groups	.011	1	.011	.010	.919
	Within Groups	158.989	158	1.006		
	Total	159.000	159			
PRICE	Between Groups	.278	1	.278	.277	.600
	Within Groups	158.722	158	1.005		
	Total	159.000	159			
IMAGE	Between Groups	.412	1	.412	.410	.523
	Within Groups	158.588	158	1.004		
	Total	159.000	159			
SATIF	Between Groups	.008	1	.008	.008	.930
	Within Groups	158.992	158	1.006		
	Total	159.000	159			
LOYALTY	Between Groups	.007	1	.007	.007	.934
	Within Groups	158.993	158	1.006		
	Total	159.000	159			

Means Plots