

Kuesioner

Surat Permohonan Pengisian Kuesioner



Universitas
Esa Unggul

UNIVERSITAS ESA UNGGUL
FAKULTAS EKONOMI DAN BISNIS

Responden Yth,

Saya Mahasiswa Program Studi Ilmu Manajemen, Fakultas Ekonomi dan Bisnis Universitas Esa Unggul.

Nama : Fadli Noor

Nim : 2014-11-009

Saat ini, saya sedang melakukan penelitian tentang Pengaruh Citra Merek, Kualitas Produk, dan Gaya Hidup, Terhadap Keputusan Pembelian Smartphone iPhone Di Wilayah Jakarta Barat untuk menyelesaikan Tugas Akhir. Maka dari itu, Saya sangat mengharapkan kesediaan Bapak/Ibu untuk mengisi kuisisioner ini.

Atas kesediaan Bapak.Ibu menjawab dengan sejujurnya dan sebaik-baiknya saya mengucapkan terima kasih.

No.Responden:

I. DATA RESPONDEN

Petunjuk:

Isilah data responden dibawah ini dengan menyilang (X) salah satu jawaban yang tersedia:

1. Jenis Kelamin
 - a. Laki-Laki
 - b. Perempuan
2. Usia
 - a. 17-23 Tahun
 - b. 24-35 Tahun
 - c. 36-45 Tahun
 - d. >45 Tahun
3. Pekerjaan
 - a. Pelajar/Mahasiswa
 - b. Pegawai Negeri Sipil
 - c. Karyawan Swasta
 - d. Wiraswasta
4. Domisili
 - a. Jakarta Barat
 - b. Luar Jakarta Barat
5. Pendapatan Sebulan
 - a. < Rp. 4.000.000,-
 - b. Rp. 4.000.001,- s/d Rp. 5.000.000,-
 - c. Rp. 5.000.001,- s/d Rp. 6.000.000,-
 - d. > Rp. 6.000.000,-
6. Faktor yang mempengaruhi pembelian Iphone
 - a. Citra Merek
 - b. Kualitas produk
 - c. Gaya Hidup
 - d. Harga
 - e. Lain-Lain

II.Pernyataan

Petunjuk Pengisian:

1. Sebelum mengisi pernyataan dibawah, bacalah petunjuk pengisian dengan baik dan isi data responden terlebih dahulu.
2. Kuisisioner penelitian ini terdiri dari 26 pernyataan
3. Berilah tanda silang (X) atau centang (V), pada kolom pernyataan **Sangat Setuju (SS), Setuju (S), Netral (N), Tidak Setuju (TS), Sangat Tidak Setuju (STS)** sesuai dengan keadaan yang sebenarnya.
4. Semua jawaban adalah benar dan tidak ada yang salah, oleh karena itu jawablah semua pernyataan sesuai dengan keadaan yang anda alami dengan **JUJUR**

No.	Pernyataan	STS	TS	N	S	SS
Citra Merek (X1)						
1	Saya merasa merek iPhone memiliki reputasi yang baik					
2	Saya merasa iPhone merupakan merek terkenal					
3	Saya merasa merek iPhone memiliki citra sebagai merek smartphone yang baik.					
4	Saya merasa merek iPhone diciptakan oleh perusahaan Apple yang memiliki citra yang baik					
5	Saya mudah mengingat Logo iPhone					
6	Saya mudah mengingat merek iPhone					
Kualitas Produk (X2)						
7	Saya merasa iPhone sangat canggih karena memiliki sistem operasi berbasis IOS Apple					

8	Saya merasa aplikasi iPhone mudah untuk digunakan					
9	Saya merasa kamera iPhone memiliki resolusi warna yang jernih					
10	Saya merasa sistem keamanan iPhone sangat baik karena menggunakan TouchID					
11	Saya merasa iPhone memiliki baterai yang tahan lama					
12	Saya merasa iPhone mudah diperbaiki ketika mengalami kerusakan					
13	Saya merasa iPhone memiliki fitur aplikasi yang lengkap					
14	Saya merasa iPhone memiliki desain yang elegan					
15	Saya merasa iPhone menawarkan pilihan warna yang menarik					
Gaya Hidup (X3)						
16	iPhone mendukung kegiatan saya sehari-hari					
17	iPhone dapat meningkatkan status sosial saya					
18	Saya lebih sering menggunakan iPhone dibanding laptop untuk mencari berbagai informasi					
19	iPhone memberikan banyak manfaat bagi kehidupan saya					
20	Saya merasa iPhone sangat diminati oleh kalangan remaja					

21	iPhone sudah sesuai dengan gaya hidup Saya saat ini					
Keputusan pembelian (Y)						
22	Saya membeli iPhone karena menawarkan berbagai jenis produk yang menarik					
23	Saya membeli iPhone karena menawarkan type produk yang menarik					
24	Saya membeli iPhone di reseller/distributor premium resmi apple					
25	Saya membeli iPhone di reseller/distributor resmi apple					
26	Saya membeli iPhone ketika saya membutuhkan					

LAMPIRAN 1**TABULASI DATA KARAKTERISTIK 30 RESPONDEN**

Jenis Kelamin	Jumlah Responden	Total
Laki-Laki	17	30
Perempuan	13	

Usia	Jumlah Responden	Total
17-23 Tahun	9	30
24-35 Tahun	21	

Pekerjaan	Jumlah Responden	Total
Pelajar/Mahasiswa	7	30
Pegawai Negeri Sipil	1	
Karyawan Swasta	22	

Penghasilan	Jumlah Responden	Total
Kurang dari Rp. 4.000.000	6	30
Rp. 4.000.001 s/d Rp. 5.000.000	6	
Rp. 5.000.001 s/d Rp. 6.000.000	6	
Lebih dari Rp. 6.000.000	12	

Domisili	Jumlah Responden	Total
Jakarta Barat	30	30

No.	Pernyataan	Reputasi baik	Reputasi Buruk
1	Apakah Merek iPhone memiliki reputasi baik?	13	17

No.	Pernyataan	Bagus	Tidak Bagus
2	Apakah iPhone memiliki ketahanan daya baterai yang bagus?	8	22

No.	Pernyataan	Meningkatkan Status Sosial	Tidak Meningkatkan Status Sosial
3	Apakah dengan membeli iPhone dapat meningkatkan status sosial di masyarakat?	14	16

No.	Pernyataan	Membeli Ulang	Tidak Membeli Ulang
4	Apakah anda memiliki keinginan untuk melakukan pembelian ulang atas produk iPhone?	12	18

Jenis Kelamin	Usia	Pekerjaan	Pendapatan Sebulan	Domisili	Apakah Merek iPhone memiliki reputasi baik?	Apakah iPhone memiliki ketahanan daya baterai yang bagus?	Apakah dengan membeli iPhone dapat meningkatkan status sosial di masyarakat?	Apakah anda memiliki keinginan untuk melakukan pembelian ulang atas produk iPhone?
Laki-Laki	24-35 Tahun	Karyawan Swasta	Rp. 5.000.000 s/d Rp. 6.000.000	Jakarta Barat	Reputasi baik	Tidak Bagus	Meningkatkan Status Sosial	Membeli Ulang

Perempuan	24-35 Tahun	Karyawan Swasta	Rp. 5.000.001 s/d Rp. 6.000.000	Jakarta Barat	Reputasi Buruk	Tidak Bagus	Tidak Meningkatkan Status Sosial	Tidak Membeli Ulang
Laki-Laki	17-23 Tahun	Karyawan Swasta	Rp. 4.000.001 s/d Rp. 5.000.000	Jakarta Barat	Reputasi baik	Bagus	Meningkatkan Status Sosial	Membeli Ulang
Laki-Laki	24-35 Tahun	Pelajar/Mahasiswa	Lebih dari Rp. 6.000.000	Jakarta Barat	Reputasi baik	Tidak Bagus	Meningkatkan Status Sosial	Tidak Membeli Ulang
Laki-Laki	24-35 Tahun	Karyawan Swasta	Kurang dari Rp. 4.000.000	Jakarta Barat	Reputasi baik	Bagus	Tidak Meningkatkan Status Sosial	Membeli Ulang
Perempuan	17-23 Tahun	Pelajar/Mahasiswa	Kurang dari Rp. 4.000.000	Jakarta Barat	Reputasi baik	Tidak Bagus	Meningkatkan Status Sosial	Membeli Ulang
Perempuan	17-23 Tahun	Pelajar/Mahasiswa	Kurang dari Rp. 4.000.000	Jakarta Barat	Reputasi baik	Bagus	Tidak Meningkatkan Status Sosial	Membeli Ulang
Laki-Laki	24-35 Tahun	Pelajar/Mahasiswa	Lebih dari Rp. 6.000.000	Jakarta Barat	Reputasi Buruk	Tidak Bagus	Tidak Meningkatkan Status Sosial	Tidak Membeli Ulang
Laki-Laki	17-23 Tahun	Karyawan Swasta	Rp. 5.000.001 s/d Rp. 6.000.000	Jakarta Barat	Reputasi Buruk	Tidak Bagus	Meningkatkan Status Sosial	Tidak Membeli Ulang
Perempuan	24-35 Tahun	Karyawan Swasta	Lebih dari Rp. 6.000.000	Jakarta Barat	Reputasi baik	Bagus	Tidak Meningkatkan Status Sosial	Membeli Ulang
Laki-Laki	17-23 Tahun	Pelajar/Mahasiswa	Rp. 5.000.001 s/d Rp. 6.000.000	Jakarta Barat	Reputasi baik	Bagus	Meningkatkan Status Sosial	Membeli Ulang

Laki-Laki	24-35 Tahun	Karyawan Swasta	Lebih dari Rp. 6.000.000	Jakarta Barat	Reputasi Buruk	Tidak Bagus	Tidak Meningkatkan Status Sosial	Tidak Membeli Ulang
Laki-Laki	24-35 Tahun	Karyawan Swasta	Lebih dari Rp. 6.000.000	Jakarta Barat	Reputasi Buruk	Tidak Bagus	Meningkatkan Status Sosial	Membeli Ulang
Perempuan	24-35 Tahun	Karyawan Swasta	Lebih dari Rp. 6.000.000	Jakarta Barat	Reputasi baik	Bagus	Tidak Meningkatkan Status Sosial	Tidak Membeli Ulang
Perempuan	17-23 Tahun	Pelajar/Mahasiswa	Kurang dari Rp. 4.000.000	Jakarta Barat	Reputasi baik	Tidak Bagus	Meningkatkan Status Sosial	Tidak Membeli Ulang
Perempuan	17-23 Tahun	Pelajar/Mahasiswa	Kurang dari Rp. 4.000.000	Jakarta Barat	Reputasi Buruk	Tidak Bagus	Meningkatkan Status Sosial	Membeli Ulang
Laki-Laki	24-35 Tahun	Karyawan Swasta	Rp. 5.000.001 s/d Rp. 6.000.000	Jakarta Barat	Reputasi Buruk	Tidak Bagus	Tidak Meningkatkan Status Sosial	Tidak Membeli Ulang
Perempuan	17-23 Tahun	Karyawan Swasta	Rp. 5.000.001 s/d Rp. 6.000.000	Jakarta Barat	Reputasi Buruk	Tidak Bagus	Tidak Meningkatkan Status Sosial	Membeli Ulang
Perempuan	24-35 Tahun	Karyawan Swasta	Lebih dari Rp. 6.000.000	Jakarta Barat	Reputasi Buruk	Tidak Bagus	Tidak Meningkatkan Status Sosial	Tidak Membeli Ulang
Perempuan	24-35 Tahun	Karyawan Swasta	Lebih dari Rp. 6.000.000	Jakarta Barat	Reputasi baik	Bagus	Tidak Meningkatkan Status Sosial	Tidak Membeli Ulang
Perempuan	24-35 Tahun	Karyawan Swasta	Rp. 4.000.001 s/d Rp. 5.000.000	Jakarta Barat	Reputasi Buruk	Tidak Bagus	Meningkatkan Status Sosial	Tidak Membeli Ulang
Laki-Laki	24-35 Tahun	Karyawan Swasta	Lebih dari Rp.	Jakarta Barat	Reputasi Buruk	Tidak Bagus	Meningkatkan Status Sosial	Tidak Membeli Ulang

	Tahun		6.000.000					
Laki-Laki	24-35 Tahun	Karyawan Swasta	Rp. 4.000.001 s/d Rp. 5.000.000	Jakarta Barat	Reputasi Buruk	Tidak Bagus	Tidak Meningkatkan Status Sosial	Tidak Membeli Ulang
Perempuan	24-35 Tahun	Karyawan Swasta	Rp. 4.000.001 s/d Rp. 5.000.000	Jakarta Barat	Reputasi Buruk	Tidak Bagus	Tidak Meningkatkan Status Sosial	Tidak Membeli Ulang
Perempuan	24-35 Tahun	Karyawan Swasta	Rp. 4.000.001 s/d Rp. 5.000.000	Jakarta Barat	Reputasi Buruk	Tidak Bagus	Meningkatkan Status Sosial	Tidak Membeli Ulang
Laki-Laki	24-35 Tahun	Karyawan Swasta	Lebih dari Rp. 6.000.000	Jakarta Barat	Reputasi baik	Bagus	Tidak Meningkatkan Status Sosial	Membeli Ulang
Laki-Laki	24-35 Tahun	Karyawan Swasta	Lebih dari Rp. 6.000.000	Jakarta Barat	Reputasi baik	Tidak Bagus	Meningkatkan Status Sosial	Tidak Membeli Ulang
Laki-Laki	24-35 Tahun	Karyawan Swasta	Lebih dari Rp. 6.000.000	Jakarta Barat	Reputasi Buruk	Tidak Bagus	Tidak Meningkatkan Status Sosial	Tidak Membeli Ulang
Laki-Laki	17-23 Tahun	Pegawai Negeri Sipil	Kurang dari Rp. 4.000.000	Jakarta Barat	Reputasi Buruk	Tidak Bagus	Tidak Meningkatkan Status Sosial	Tidak Membeli Ulang
Laki-Laki	24-35 Tahun	Karyawan Swasta	Rp. 4.000.001 s/d Rp. 5.000.000	Jakarta Barat	Reputasi Buruk	Tidak Bagus	Meningkatkan Status Sosial	Membeli Ulang

LAMPIRAN 2
TABULASI DATA KARAKTERISTIK 135 RESPONDEN

Jenis Kelamin	Jumlah Responden	Total
Laki-Laki	88	135
Perempuan	47	

Usia	Jumlah Responden	Total
17-23 Tahun	33	135
23-35 Tahun	100	
36-45 Tahun	2	

Pekerjaan	Jumlah Responden	Total
Karyawan Swasta	94	135
Pelajar/Mahasiswa	25	
Wirausaha	12	
Pegawai Negeri Sipil	4	

Penghasilan	Jumlah Responden	Total
Kurang dari Rp. 4.000.000	38	135
Rp. 4.000.001 s/d Rp. 5.000.000	38	
Rp. 5.000.001 s/d Rp. 6.000.000	32	
Lebih dari Rp. 6.000.000	27	

Faktor yang mempengaruhi	Jumlah Responden	Total
Harga	27	135
Citra Merek	37	
Gaya Hidup	11	

Kualitas Produk	33
Lain-Lain	27

- Citra Merek

No	X1_1	X1_2	X1_3	X1_4	X1_5	X1_6
1	5	5	5	5	3	3
2	4	4	3	4	2	2
3	4	5	5	5	3	3
4	4	5	4	5	2	2
5	4	5	4	4	4	4
6	4	5	5	5	3	3
7	5	5	5	5	3	3
8	5	5	5	5	5	5
9	5	5	5	5	5	5
10	4	5	5	4	4	4
11	5	5	5	5	4	4
12	5	5	4	4	5	5
13	3	5	4	4	3	3
14	3	5	3	5	2	2
15	4	5	4	5	3	3
16	5	5	5	5	3	3
17	3	3	3	5	2	2

18	4	4	4	5	3	3
19	4	5	4	3	5	5
20	4	5	5	5	2	2
21	5	5	5	5	2	2
22	5	5	5	5	2	2
23	3	3	3	3	3	3
24	5	5	5	4	2	2
25	5	5	4	3	2	2
26	4	5	4	5	2	2
27	5	5	5	5	4	4
28	4	3	3	5	3	3
29	5	5	5	5	3	3
30	1	1	2	1	1	1
31	4	5	4	5	3	3
32	5	5	5	5	2	2
33	4	5	5	5	3	3
34	4	4	5	5	4	4
35	4	5	4	4	4	4
36	5	5	5	5	4	4
37	4	5	4	5	2	2
38	5	5	5	5	3	3
39	5	5	5	5	3	3
40	4	4	4	5	2	2
41	5	5	5	5	4	4

42	4	5	5	5	4	4
43	4	5	5	5	4	4
44	4	5	4	5	2	2
45	1	5	5	5	5	5
46	4	5	4	5	3	3
47	5	5	5	5	2	2
48	4	5	4	5	4	4
49	5	4	4	5	2	2
50	4	5	4	5	3	3
51	5	5	5	5	4	4
52	5	5	5	5	4	4
53	5	5	5	5	4	4
54	5	5	5	5	4	4
55	4	5	4	5	3	3
56	4	5	4	5	4	4
57	4	5	5	5	3	3
58	5	5	5	5	3	3
59	5	5	5	4	2	2
60	4	5	5	5	3	3
61	5	5	5	5	3	3
62	5	5	5	5	3	3
63	4	5	5	5	4	4
64	5	5	4	3	2	2
65	5	5	4	3	2	2

66	5	5	4	3	2	2
67	5	5	5	5	5	5
68	5	5	5	5	5	5
69	5	4	5	5	2	2
70	4	5	5	5	3	3
71	3	3	2	5	3	3
72	5	5	5	5	3	3
73	5	5	5	5	4	4
74	4	4	4	5	3	3
75	4	5	5	5	5	5
76	4	5	5	5	5	5
77	5	5	5	5	4	4
78	4	4	4	4	4	4
79	5	5	5	4	4	4
80	3	3	3	5	2	2
81	4	5	4	3	5	5
82	5	5	5	5	2	2
83	5	5	5	5	2	2
84	3	3	3	3	3	3
85	5	5	5	4	2	2
86	4	5	4	5	2	2
87	5	5	5	5	4	4
88	5	5	5	5	3	3
89	1	1	2	1	1	1

90	4	5	4	5	3	3
91	5	5	5	5	2	2
92	4	5	5	5	3	3
93	4	4	5	5	4	4
94	5	5	5	5	4	4
95	4	5	4	5	2	2
96	5	5	5	5	3	3
97	4	5	4	5	4	4
98	5	5	5	5	3	3
99	4	4	4	5	2	2
100	4	5	4	4	4	4
101	5	5	5	5	3	3
102	5	5	5	5	5	5
103	5	5	5	5	5	5
104	4	5	5	3	4	4
105	5	5	5	5	4	4
106	5	5	5	4	2	2
107	5	5	5	3	2	2
108	5	5	5	4	4	4
109	4	5	4	4	2	2
110	5	5	5	5	3	3
111	4	5	4	5	4	4
112	5	5	5	2	3	3
113	4	4	4	3	2	2

114	5	5	5	4	4	4
115	4	5	5	5	4	4
116	5	5	5	5	4	4
117	3	5	4	3	3	3
118	3	5	3	4	2	2
119	4	5	4	4	3	3
120	5	5	5	3	3	3
121	3	3	3	4	2	2
122	2	4	4	3	3	3
123	4	5	4	3	5	5
124	4	5	5	3	2	2
125	5	5	5	5	2	2
126	3	3	3	3	3	3
127	5	5	5	3	2	2
128	5	5	4	2	2	2
129	4	5	4	5	2	2
130	5	5	5	5	4	4
131	4	3	3	3	3	3
132	5	5	5	5	3	3
133	3	1	2	4	2	2
134	4	5	4	3	3	3
135	5	5	5	5	2	2

- **Kualitas Produk**

No	X2_1	X2_2	X2_3	X2_4	X2_5	X2_6	X2_7	X2_8	X2_9
1	5	5	5	5	1	3	5	5	5

2	3	3	3	2	2	2	2	3	2
3	4	4	4	4	3	3	4	5	5
4	1	5	4	4	2	3	1	5	5
5	4	4	4	4	4	4	4	4	4
6	4	5	4	5	3	3	4	5	5
7	5	5	5	5	3	3	5	5	5
8	5	5	5	5	5	5	5	5	5
9	5	5	5	5	5	5	5	5	5
10	4	5	5	5	4	5	3	5	5
11	5	4	5	5	4	4	5	5	4
12	5	4	4	4	5	2	4	3	3
13	4	4	5	3	1	3	3	4	3
14	3	4	4	4	2	2	3	4	4
15	4	4	4	3	3	4	3	4	4
16	5	2	5	3	3	3	3	4	3
17	3	3	5	3	2	1	4	5	4
18	3	2	4	3	3	3	3	5	4
19	4	4	4	4	5	3	3	5	4
20	4	4	5	4	2	3	3	4	4
21	5	4	5	5	2	2	4	5	5
22	4	5	5	5	2	5	3	4	3
23	4	3	4	3	3	3	3	3	3
24	4	5	4	4	2	4	4	5	2
25	1	4	5	2	2	5	2	5	4
26	4	4	5	5	2	1	5	5	5
27	4	5	5	5	4	3	4	5	5
28	3	3	3	3	3	3	3	5	5
29	4	4	5	5	3	4	4	5	3
30	1	1	1	1	1	1	1	1	2
31	4	3	3	4	3	2	3	3	2
32	5	5	5	5	2	2	3	5	5
33	4	4	4	4	3	3	4	4	3
34	5	5	4	5	4	4	4	5	5
35	4	4	4	4	4	4	4	4	4
36	5	5	5	5	4	4	5	5	4
37	5	4	5	5	2	3	4	5	5
38	5	5	5	5	3	3	5	5	5
39	5	1	5	5	3	1	4	4	3
40	4	3	5	5	2	1	4	5	4
41	5	5	5	5	4	4	5	5	4

42	5	5	5	5	4	5	5	5	5
43	5	5	5	5	4	5	5	5	5
44	4	4	5	5	2	1	5	5	5
45	5	5	5	5	5	5	5	5	5
46	3	2	4	3	1	1	3	5	4
47	5	4	5	5	2	2	4	5	5
48	4	3	3	3	1	1	2	4	3
49	3	3	5	4	2	2	3	5	4
50	3	3	5	5	3	2	4	5	5
51	5	5	5	5	4	4	4	5	5
52	5	5	5	5	4	4	4	5	5
53	5	5	5	5	4	4	5	5	4
54	4	5	5	5	4	3	4	5	5
55	3	2	4	3	1	1	3	5	4
56	4	4	5	4	4	4	4	5	5
57	4	4	4	4	3	3	4	5	5
58	5	5	5	5	3	3	5	5	5
59	4	5	4	4	2	4	4	5	2
60	4	4	4	4	3	3	4	4	3
61	5	3	4	4	3	3	4	5	5
62	5	5	5	5	3	3	5	5	5
63	4	4	3	3	4	2	3	3	2
64	1	4	5	2	2	5	2	5	4
65	1	4	5	2	2	5	2	5	4
66	1	4	5	2	2	5	2	5	4
67	5	5	5	5	5	4	4	5	5
68	5	5	5	5	5	5	5	5	5
69	4	4	5	4	2	4	3	5	3
70	5	3	5	5	3	3	5	5	5
71	1	3	5	2	3	2	2	4	3
72	5	5	5	5	5	5	5	5	5
73	5	5	5	5	5	5	5	5	5
74	4	4	4	4	4	3	4	4	4
75	5	3	5	5	3	3	5	5	5
76	5	3	5	5	3	3	5	5	5
77	5	5	5	5	4	3	3	5	4
78	3	3	4	4	3	3	3	4	4
79	5	5	5	5	4	4	5	5	4
80	3	3	5	3	2	1	4	5	4
81	4	4	4	4	5	3	3	5	4

82	5	4	5	5	2	2	4	5	5
83	4	5	5	5	2	5	3	4	3
84	4	3	4	3	3	3	3	3	3
85	4	5	4	4	2	4	4	5	2
86	4	4	5	5	2	1	5	5	5
87	4	5	5	5	4	3	4	5	5
88	4	4	5	5	3	4	4	5	3
89	1	1	1	1	1	1	1	1	2
90	4	3	3	4	3	2	3	3	2
91	5	4	4	5	2	3	4	5	5
92	4	4	4	4	3	3	4	4	3
93	5	5	4	5	4	4	4	5	5
94	5	5	5	5	4	4	5	5	4
95	5	4	5	5	2	3	4	5	5
96	5	5	5	5	3	3	5	5	5
97	5	4	4	5	4	4	4	5	5
98	5	1	5	5	3	1	4	4	3
99	4	3	5	5	2	1	4	5	4
100	4	4	4	4	4	4	4	4	4
101	5	5	5	5	3	3	5	5	5
102	5	5	5	5	5	5	5	5	5
103	5	5	5	5	5	5	5	5	5
104	4	5	5	5	4	5	3	5	5
105	5	4	5	5	4	4	5	5	4
106	5	4	4	3	2	3	3	5	5
107	5	4	4	4	2	2	5	5	3
108	5	5	5	5	4	4	5	5	4
109	5	4	5	5	2	3	4	5	5
110	5	5	5	5	3	3	5	5	5
111	5	4	4	5	4	4	4	5	5
112	5	1	5	5	3	3	4	4	3
113	4	3	5	5	2	1	4	5	4
114	5	5	5	5	4	3	5	5	4
115	5	5	5	5	4	5	5	4	5
116	5	4	5	5	4	4	5	5	4
117	4	4	5	3	3	3	3	4	3
118	3	4	4	4	2	2	3	4	4
119	4	4	4	3	3	4	3	4	4
120	5	2	5	3	3	3	3	4	3
121	3	3	5	3	2	4	4	5	4

122	3	2	4	3	3	3	3	5	4
123	4	4	4	4	5	3	3	5	4
124	4	4	5	4	2	3	3	4	4
125	5	4	5	5	2	2	4	5	5
126	4	3	4	3	3	3	3	3	3
127	4	5	4	4	2	4	4	5	2
128	2	4	5	2	2	5	2	5	4
129	4	4	5	5	2	3	5	5	5
130	4	5	5	5	4	3	4	5	5
131	3	3	3	3	3	3	3	5	5
132	4	4	5	5	3	4	4	5	3
133	4	1	1	1	2	3	1	3	2
134	4	3	3	4	3	2	3	3	2
135	5	5	5	5	2	2	3	5	5

- **Gaya Hidup**

No	X3_1	X3_2	X3_3	X3_4	X3_5	X3_6
1	5	5	3	4	5	5
2	1	1	1	1	1	1
3	4	2	4	3	5	4
4	3	2	1	1	5	3
5	4	4	4	4	4	4
6	4	5	3	4	5	4
7	5	5	5	5	5	5
8	5	5	5	5	5	5
9	5	5	5	5	5	5
10	1	1	1	3	4	1
11	5	5	5	5	5	5
12	5	5	4	5	5	4
13	3	4	2	3	4	4
14	3	3	4	3	4	4
15	5	3	5	4	4	4
16	3	3	3	3	3	3
17	2	1	1	4	3	3
18	2	4	2	3	4	3
19	3	3	3	3	4	4
20	3	4	4	4	4	4
21	5	4	5	4	4	4
22	4	1	5	4	3	3

23	3	3	3	3	3	3
24	4	4	4	5	4	3
25	1	5	1	5	2	5
26	5	4	5	5	4	5
27	4	5	5	4	5	5
28	3	5	2	3	5	3
29	5	5	5	3	5	5
30	1	1	1	2	2	2
31	2	5	3	2	4	2
32	5	4	5	5	5	5
33	5	4	3	4	5	4
34	4	4	4	4	4	4
35	4	4	4	4	4	4
36	5	4	5	5	4	5
37	4	5	4	4	4	4
38	5	5	5	5	5	5
39	1	1	2	1	4	1
40	3	2	2	3	5	2
41	5	4	5	5	4	5
42	5	5	5	5	5	5
43	5	5	5	5	5	5
44	5	4	5	5	4	5
45	5	4	3	3	5	3
46	3	4	5	2	5	5
47	5	4	5	4	4	4
48	3	2	1	2	4	1
49	4	4	3	4	5	4
50	4	5	5	5	5	4
51	5	4	5	5	5	5
52	5	4	5	5	5	5
53	5	4	5	5	4	5
54	4	5	5	4	5	5
55	3	4	5	2	5	5
56	5	4	4	4	5	4
57	4	2	4	3	5	4
58	5	4	5	5	5	5
59	4	4	4	5	4	3
60	5	4	3	4	5	4
61	5	5	3	3	3	4
62	5	4	5	5	5	5

63	4	4	2	3	5	3
64	1	5	1	5	2	5
65	1	5	1	5	2	5
66	1	5	1	5	2	5
67	5	5	5	5	5	5
68	5	5	5	5	5	5
69	4	4	2	3	3	3
70	5	4	5	5	5	5
71	3	5	3	2	4	3
72	5	5	5	5	5	5
73	5	4	4	5	5	5
74	4	4	3	3	4	4
75	5	4	5	5	5	5
76	5	4	5	5	5	5
77	4	5	5	5	5	5
78	3	3	3	3	4	3
79	5	4	5	5	4	5
80	2	1	1	4	3	3
81	3	3	3	3	4	4
82	5	4	5	4	4	4
83	4	1	5	4	3	3
84	3	3	3	3	3	3
85	4	4	4	5	4	3
86	5	4	5	5	4	5
87	4	5	5	4	5	5
88	5	5	5	3	5	5
89	1	1	1	2	2	2
90	2	5	3	2	4	2
91	4	5	3	3	4	3
92	5	4	3	4	5	4
93	4	4	4	4	4	4
94	5	4	5	5	4	5
95	4	5	4	4	4	4
96	5	5	5	5	5	5
97	4	4	5	3	5	4
98	1	1	2	1	4	1
99	3	2	2	3	5	2
100	4	4	4	4	4	4
101	5	5	5	5	5	5
102	5	5	5	5	5	5

103	5	5	5	5	5	5
104	1	1	1	3	4	1
105	5	5	5	5	5	5
106	3	5	2	3	5	3
107	3	3	3	4	5	3
108	5	4	5	5	4	5
109	4	5	4	4	4	4
110	5	5	5	5	5	5
111	4	4	5	3	5	4
112	1	1	2	1	4	1
113	3	2	2	3	5	2
114	5	4	5	5	4	5
115	5	5	5	5	5	5
116	5	5	5	5	5	5
117	3	4	2	3	4	4
118	3	3	4	3	4	4
119	5	3	5	4	4	4
120	3	3	3	3	3	3
121	2	1	1	4	3	3
122	2	4	2	3	4	3
123	3	3	3	3	4	4
124	3	4	4	4	4	4
125	5	4	5	4	4	4
126	3	3	3	3	3	3
127	4	4	4	5	4	3
128	1	5	1	5	2	5
129	5	4	5	5	4	5
130	4	5	5	4	5	5
131	3	5	2	3	5	3
132	5	5	5	3	5	5
133	1	1	1	2	2	2
134	2	5	3	2	4	2
135	5	4	5	5	5	5

- **Keputusan Pembelian**

No	Y_1	Y_2	Y_3	Y_4	Y_5
1	5	4	4	4	4
2	1	1	1	5	5
3	4	4	3	4	4

4	1	1	1	1	5
5	4	4	4	4	4
6	4	4	5	5	4
7	5	5	5	5	3
8	5	5	5	5	5
9	5	5	5	5	5
10	3	4	4	4	3
11	5	5	5	5	5
12	4	5	4	5	3
13	3	3	3	3	4
14	4	3	4	4	4
15	4	4	1	1	4
16	3	3	3	3	3
17	4	3	1	5	5
18	3	4	4	5	5
19	3	4	4	4	5
20	3	4	3	5	3
21	5	5	5	5	4
22	4	4	5	5	5
23	3	3	3	3	3
24	3	3	1	4	4
25	2	5	1	5	2
26	5	5	1	2	4
27	5	4	4	4	4
28	3	3	2	4	5
29	5	5	5	5	5
30	1	2	1	1	2
31	3	3	2	3	3
32	5	5	5	5	5
33	4	4	5	5	5
34	4	4	5	4	5
35	4	4	4	4	4
36	4	4	1	5	3
37	4	4	4	4	5
38	5	5	5	5	3
39	2	2	2	3	3
40	3	3	3	3	5
41	4	4	1	5	3
42	5	4	5	5	5
43	5	4	5	5	5

44	5	5	1	2	4
45	4	4	4	5	3
46	4	5	1	2	5
47	5	5	5	5	4
48	1	1	1	1	1
49	3	4	4	4	5
50	4	4	3	3	5
51	3	3	5	5	5
52	3	3	5	5	5
53	4	4	1	5	3
54	5	4	4	4	4
55	4	5	1	2	5
56	4	4	4	4	4
57	4	4	3	4	4
58	5	5	5	5	5
59	3	3	1	4	4
60	4	4	5	5	5
61	3	3	3	3	2
62	5	5	5	5	5
63	4	2	4	4	5
64	2	5	1	5	2
65	2	5	1	5	2
66	2	5	1	5	2
67	5	5	5	5	5
68	5	5	5	5	5
69	5	5	5	5	5
70	5	5	3	5	5
71	3	3	2	3	2
72	5	5	5	5	5
73	5	5	5	5	5
74	4	4	4	4	4
75	5	5	3	5	5
76	5	5	3	5	5
77	5	5	5	5	5
78	3	3	3	3	3
79	4	4	1	5	3
80	4	3	1	5	5
81	3	4	4	4	5
82	5	5	5	5	4
83	4	4	5	5	5

84	3	3	3	3	3
85	3	3	1	4	4
86	5	5	1	2	4
87	5	4	4	4	4
88	5	5	5	5	5
89	1	2	1	1	2
90	3	3	2	3	3
91	5	5	4	5	5
92	4	4	5	5	5
93	4	4	5	4	5
94	4	4	1	5	3
95	4	4	4	4	5
96	5	5	5	5	3
97	5	5	5	5	4
98	2	2	2	3	3
99	3	3	3	3	5
100	4	4	4	4	4
101	5	5	5	5	3
102	5	5	5	3	5
103	5	5	5	5	5
104	3	4	4	3	3
105	5	5	5	5	5
106	4	4	5	3	5
107	3	4	5	5	5
108	4	4	1	5	3
109	4	4	4	4	5
110	5	5	5	5	3
111	5	5	5	5	4
112	2	2	2	3	3
113	3	3	3	3	5
114	4	4	1	5	3
115	5	4	5	5	5
116	5	5	5	5	5
117	3	3	3	3	4
118	4	3	4	4	4
119	4	4	1	4	4
120	3	3	3	3	3
121	4	3	1	5	5
122	3	4	4	5	4
123	3	4	4	4	5

124	3	4	3	5	3
125	5	5	5	5	4
126	3	3	3	3	3
127	3	3	1	4	4
128	2	5	1	5	2
129	5	5	1	2	4
130	5	4	4	4	3
131	3	3	2	4	5
132	5	5	5	5	5
133	1	2	1	1	2
134	3	3	2	3	3
135	5	5	5	5	5

LAMPIRAN 3
HASIL SMART PLS

SmartPLS Report

Please cite the use of SmartPLS: Ringle, C. M., Wende, S., and Becker, J.-M. 2015. "SmartPLS 3." Boenningstedt: SmartPLS GmbH, <http://www.smartpls.com>.

- Outer Loading

Outer Loadings

	Citra Merek	Kualitas Produk	Gaya Hidup	Keputusan Pembelian
X1_1	0.613			
X1_2	0.781			
X1_3	0.833			
X1_4	0.717			
X1_5	0.547			
X1_6	0.766			
X2_1		0.627		
X2_2		0.683		
X2_3		0.729		
X2_4		0.833		
X2_5		0.568		
X2_6		0.504		
X2_7		0.802		
X2_8		0.716		
X2_9		0.773		
X3_1			0.875	
X3_2			0.787	
X3_3			0.856	
X3_4			0.768	
X3_5			0.619	
X3_6			0.860	
Y_1				0.879
Y_2				0.810
Y_3				0.768
Y_4				0.794

Y_5				0.612

	Citra Merek	Kualitas Produk	Gaya Hidup	Keputusan Pembelian
X1_2	0.808			
X1_3	0.850			
X1_4	0.740			
X1_6	0.755			
X2_3		0.770		
X2_4		0.825		
X2_7		0.810		
X2_8		0.805		
X2_9		0.739		
X3_1			0.844	
X3_2			0.706	
X3_3			0.843	
X3_4			0.823	
X3_6			0.892	
Y_1				0.882
Y_2				0.858
Y_3				0.732
Y_4				0.709

Construct Reliability and Validity

	Cronbach's Alpha	Average Variance Extracted (AVE)	rho_A	Composite Reliability
Citra Merek	0.801	0.623	0.836	0.868
Kualitas Produk	0.850	0.625	0.855	0.893
Gaya Hidup	0.880	0.679	0.886	0.913
Keputusan Pembelian	0.812	0.638	0.856	0.875

Cross Loadings

	Citra Merek	Kualitas Produk	Gaya Hidup	Keputusan Pembelian
X1_2	0.808	0.459	0.369	0.374
X1_3	0.850	0.626	0.517	0.552
X1_4	0.740	0.535	0.317	0.337
X1_6	0.755	0.356	0.286	0.383
X2_3	0.442	0.770	0.474	0.518
X2_4	0.664	0.825	0.581	0.606
X2_7	0.537	0.810	0.662	0.624
X2_8	0.491	0.805	0.453	0.501
X2_9	0.354	0.739	0.481	0.533
X3_1	0.574	0.646	0.844	0.675
X3_2	0.317	0.383	0.706	0.551
X3_3	0.505	0.627	0.843	0.652
X3_4	0.274	0.554	0.823	0.602
X3_6	0.318	0.560	0.892	0.663
Y_1	0.532	0.708	0.767	0.882
Y_2	0.336	0.592	0.722	0.858
Y_3	0.511	0.439	0.411	0.732
Y_4	0.354	0.469	0.446	0.709

Construct Reliability and Validity

	Cronbach's Alpha	Average Variance Extracted (AVE)	rho_A	Composite Reliability
Citra Merek	0.801	0.623	0.836	0.868
Kualitas Produk	0.850	0.625	0.855	0.893
Gaya Hidup	0.880	0.679	0.886	0.913
Keputusan Pembelian	0.812	0.638	0.856	0.875

Inner Model

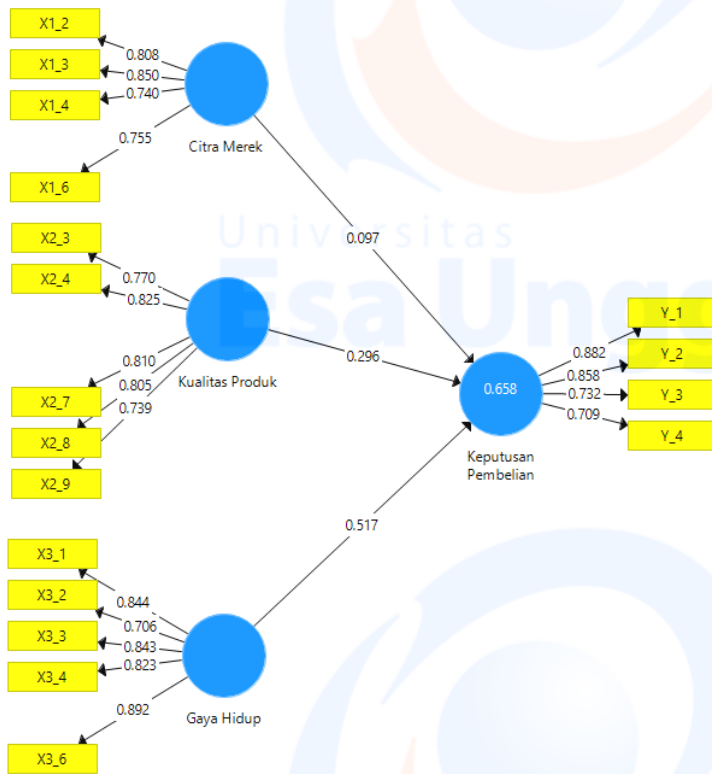

R Square

	R Square	R Square Adjusted
Keputusan Pembelian	0.658	0.650

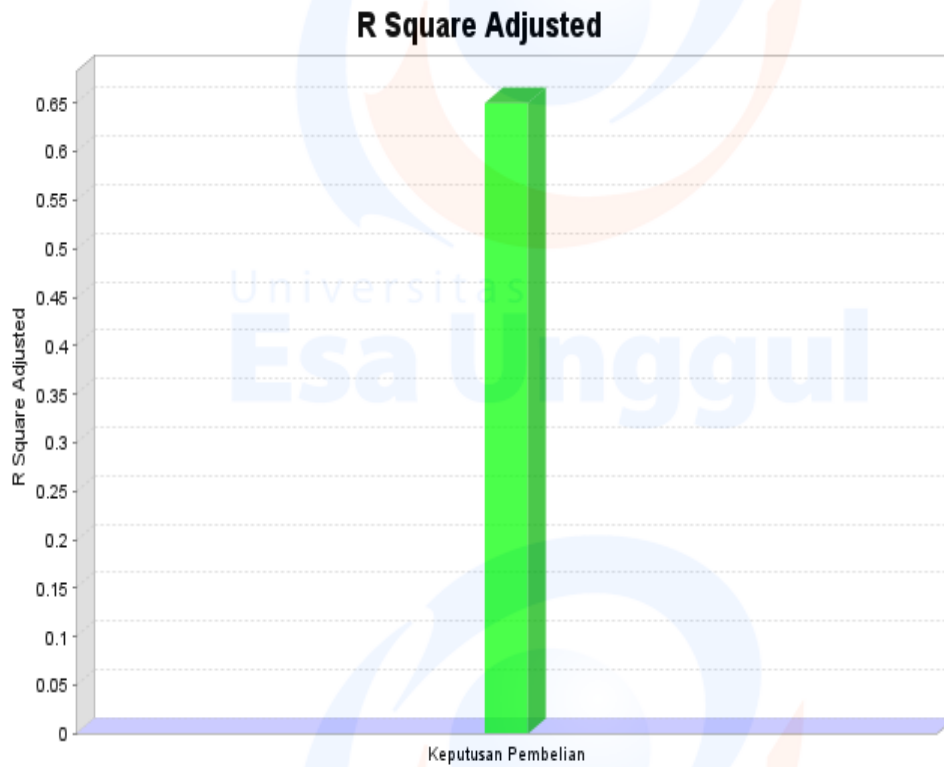
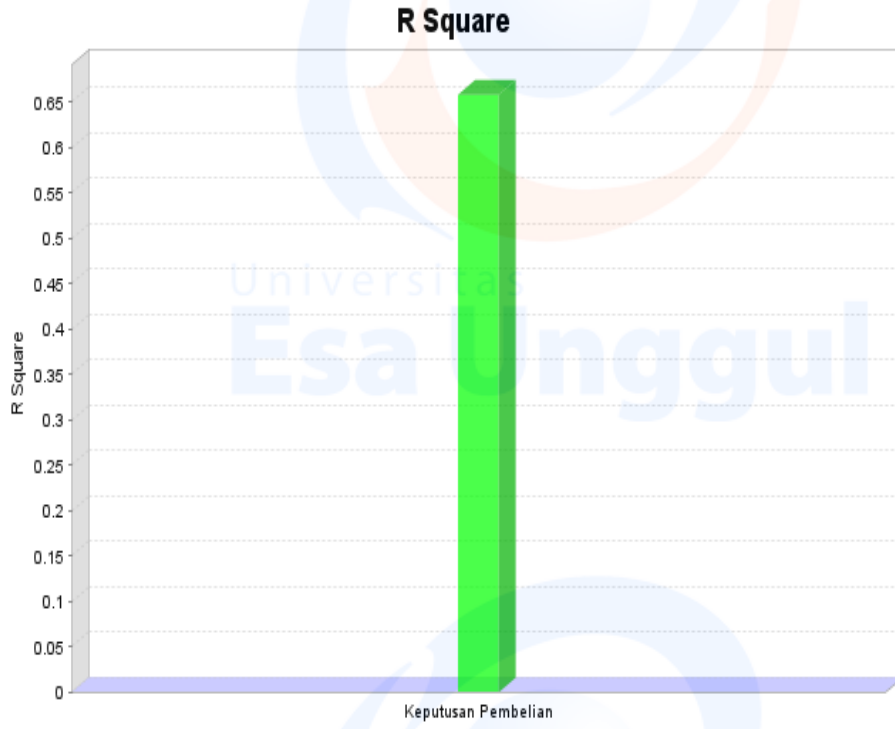

Path
Coefficients

Mean, STDEV, T-
Values, P-Values

	Original Sample (O)	Sample Mean (M)	Standard Deviation (STDEV)	T Statistics (O/STDEV)	P Values
Citra Merek -> Keputusan Pembelian	0.097	0.105	0.075	1.293	0.197
Kualitas Produk -> Keputusan Pembelian	0.296	0.297	0.072	4.107	0.000
Gaya Hidup -> Keputusan Pembelian	0.517	0.516	0.064	8.052	0.000