

# Desain Gambar Produk *Clamp Bladder*

- Komponen Besi PCN

Part Name	Material	Qty	RevNo	Revision note	Date	Signature	Checked
					17/09/2020		

PROJECTION	
Date	QTY
UNIT	
CUSTOMER	
SUPPLIER	
COLOR/HARDNESS	
DESIGN	
ANTO DRAWING	
ANTO CHECKED	
EDL.M CHECKED	
APPROVE	
IR.MAHMURI	

• Komponen *Bushing* Kuningan

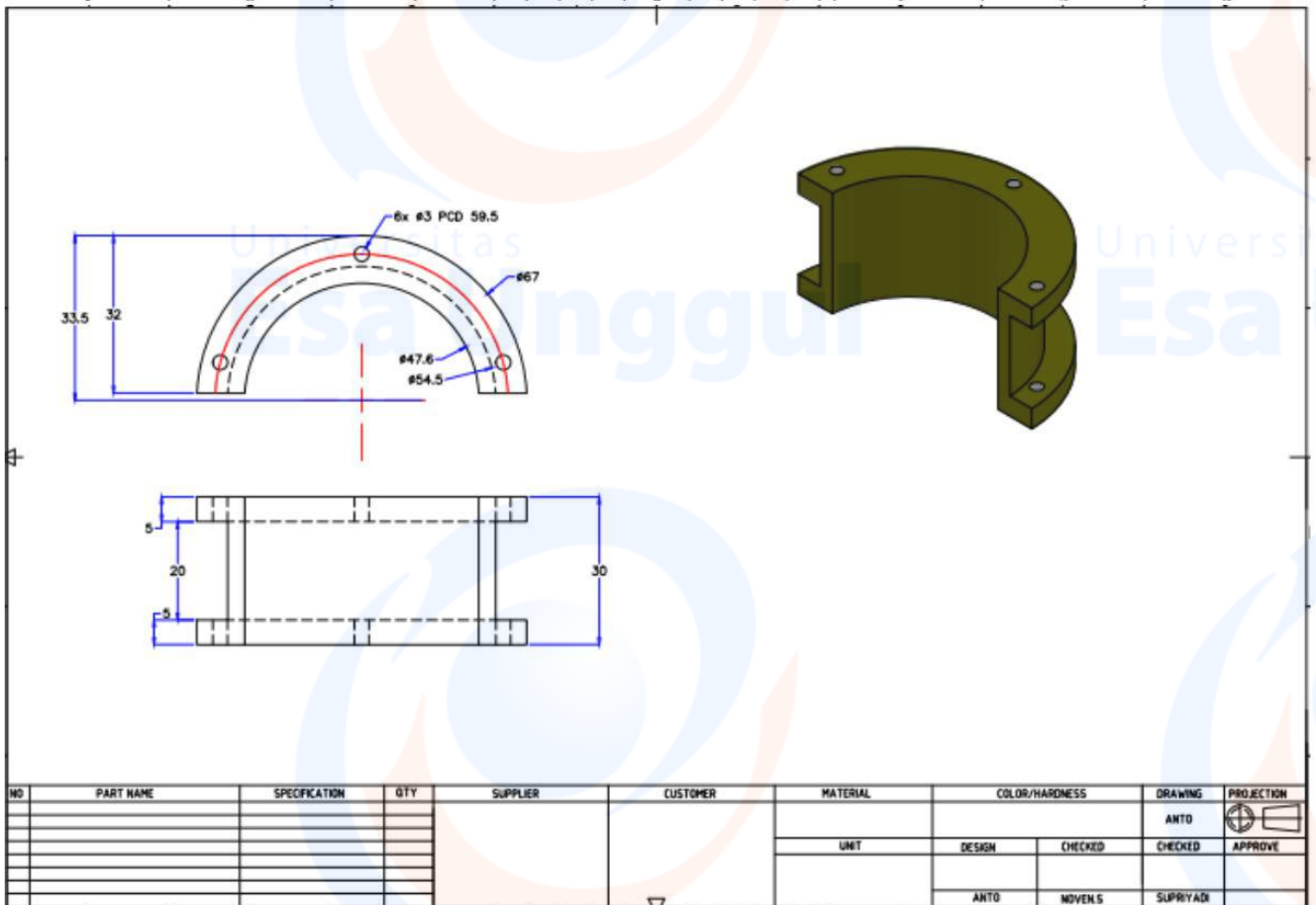
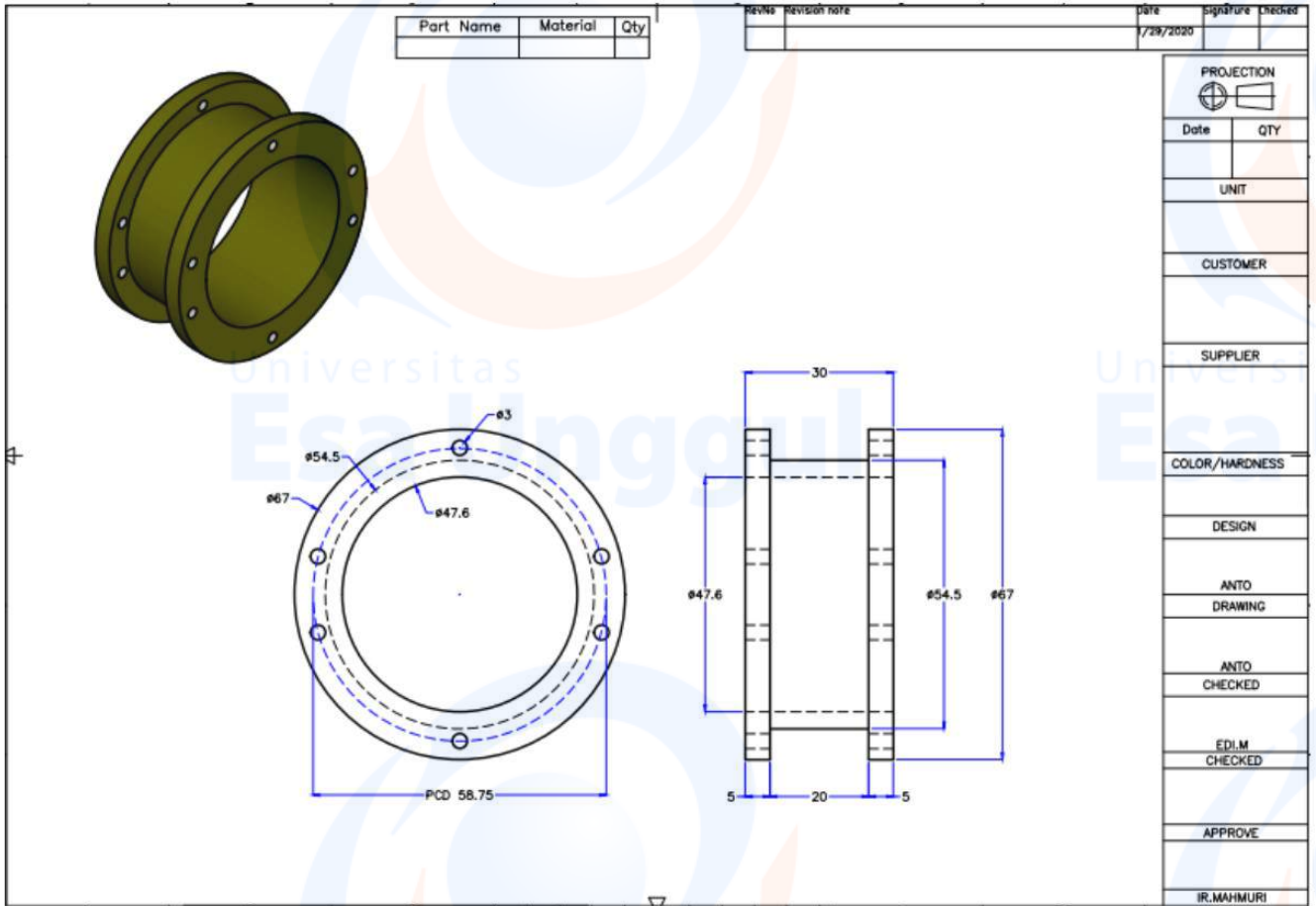

## Desain Gambar Produk *Adjuster Bladder*



M230004E

M230 004E-1

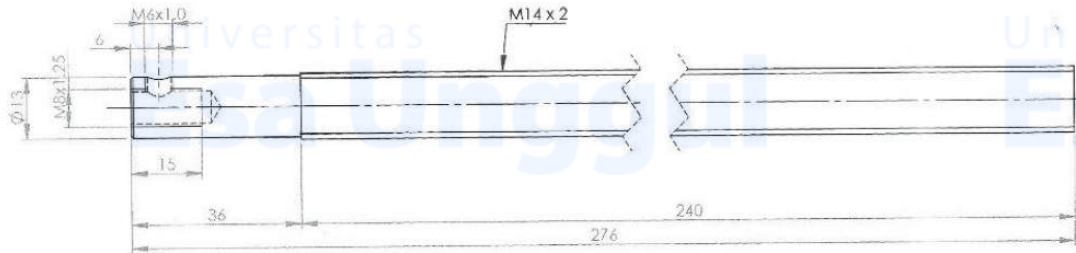

PT. GAJAH TUNGGAL Tbk.  
Radial Tire Division  
ENGINEERING DEPARTMENT

Drawn ISMAIL  
Check 1 LILIK  
Check 2 SUNARDI  
Approve

Draw. No. KRB/076/02/17  
Date 14-PEB-2017  
Scale free  
UOM mm

Item	Description	Material	Quantity	Remarks
1	Adjuster bladder	S45C		M14 x 2 panjang 276 mm
Part Number			File Name	
Draw. Name			ADJUSTER BLADDER CASEKRB M14 x 2 Total Length 276 mm	

## Desain Gambar Produk *Roda Lorry*

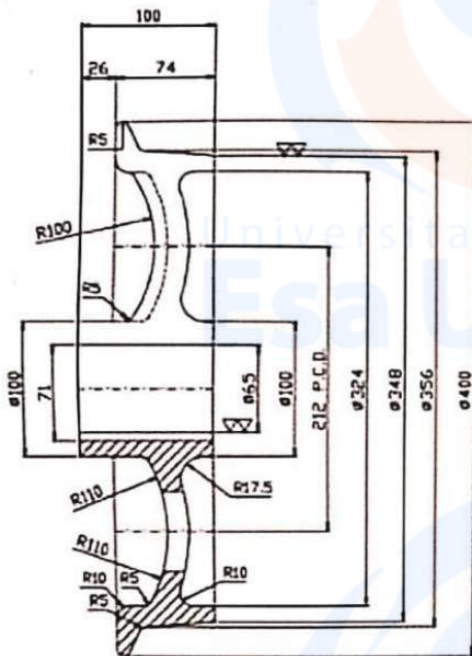

SECTION : AA

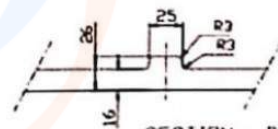
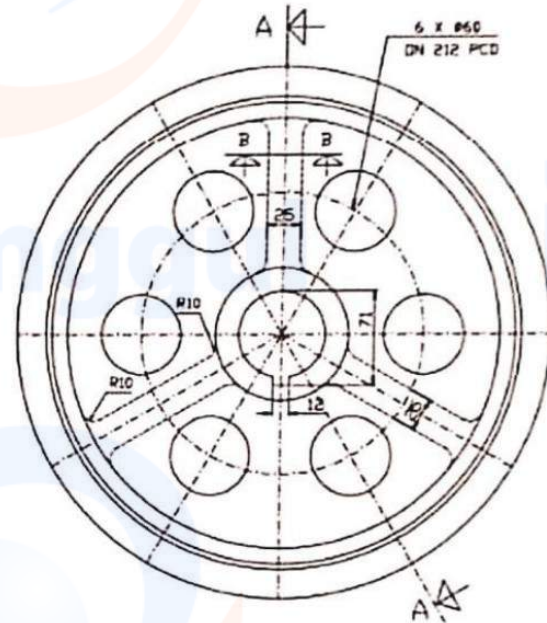

SECTION : BB

## 6. RODA LORRY.

Mat: CAST IRON.

No.	Revisi	Uraian	Tgl.
1			
2			
3			

## Block Layout Lima Alternatif Layout Hasil Software BLOCPLAN

Alternatif Layout 1

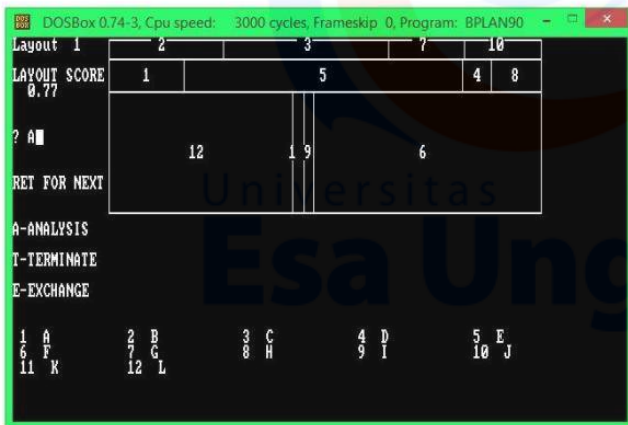

Alternatif Layout 2



Alternatif Layout 3

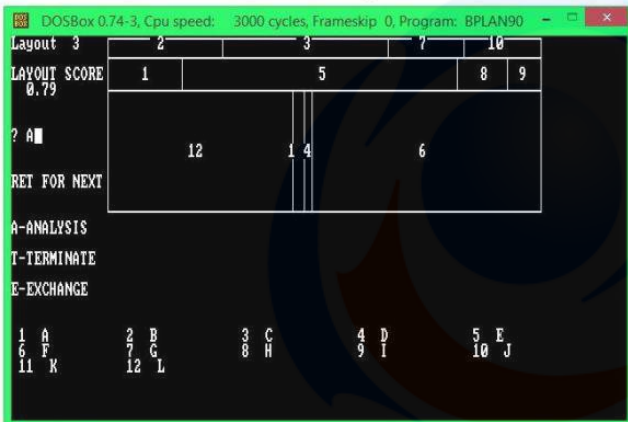

Alternatif Layout 15

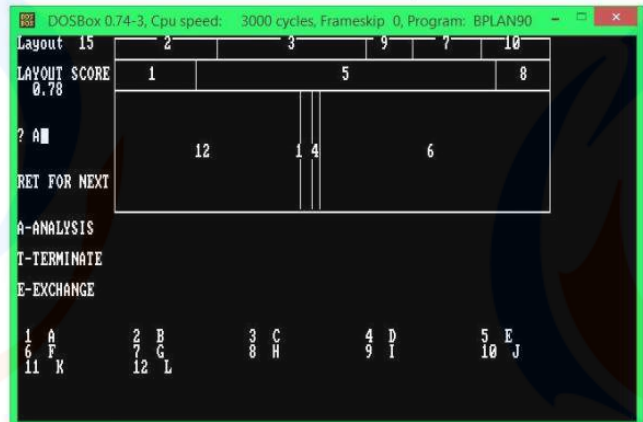

Alternatif Layout 18

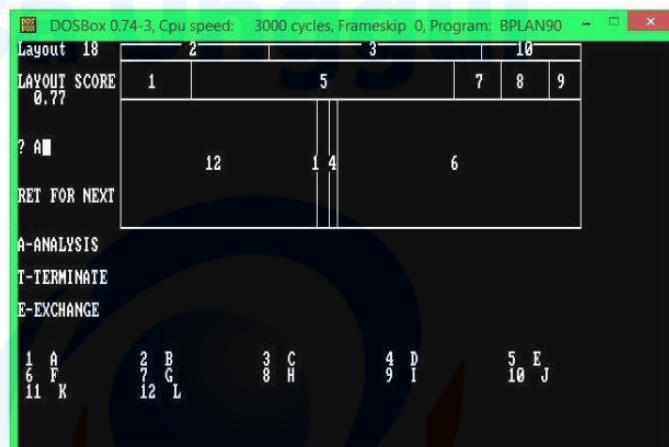

## Area Allocation Diagram (AAD) Alternatif Layout Hasil Software BLOCPLAN

AAD Alternatif Layout Peringkat Pertama

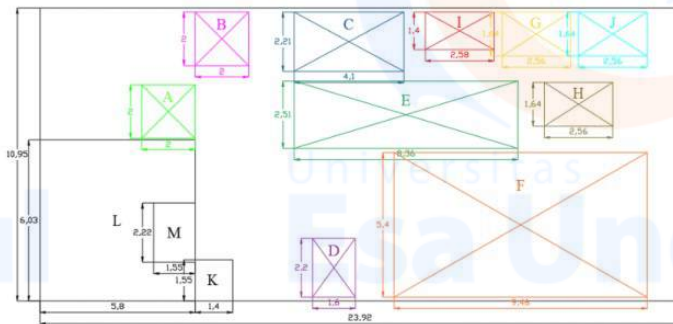

AAD Alternatif Layout Peringkat Kedua

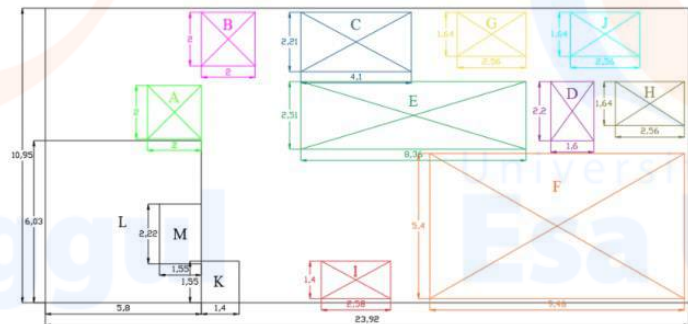

AAD Alternatif Layout Peringkat Ketiga

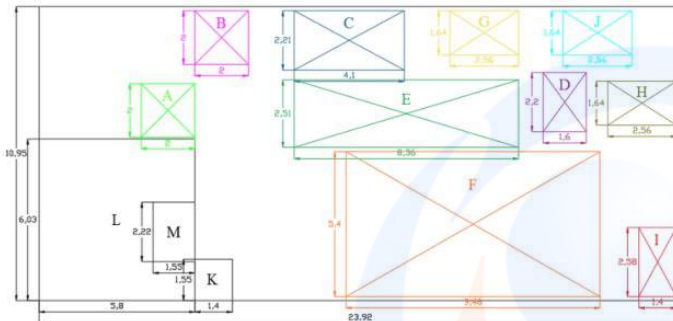

AAD Alternatif Layout Peringkat Keempat

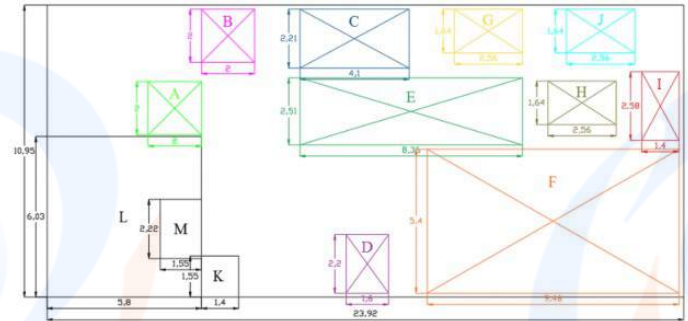

AAD Alternatif Layout Peringkat Kelima

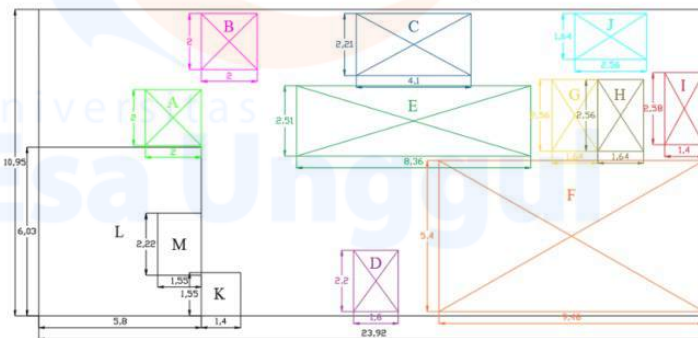

Warna	Kode	Keterangan
Hijau	A	Shipping Area
Pink	B	Receiving Area
Biru Tua	C	Area Mesin CNC
Ungu	D	Area Mesin Bor Radial
Hijau Tua	E	Area Mesin Milling
Orange	F	Area Mesin Bubut
Kuning	G	Grinding Area
Abu-Abu	H	Welding Area
Merah	I	Area Mesin Shaping
Biru	J	Cutting Area
Hitam	K	Toilet Lantai Produksi
Hitam	L	Kantor Lantai 1&2
Hitam	M	Toilet Kantor

**Area Allocation Diagram (AAD) Layout Existing**

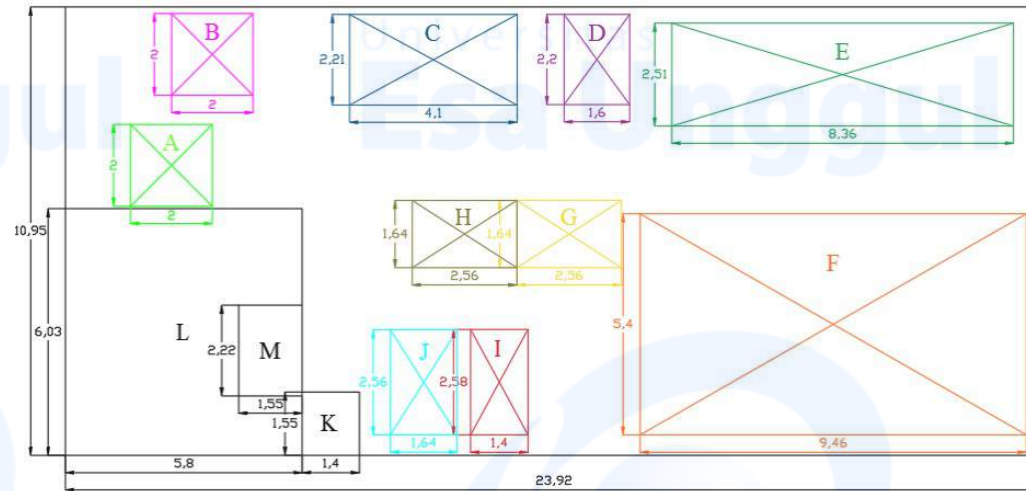

**Area Allocation Diagram (AAD) Layout Modifikasi (Alternatif Layout Peringkat Kedua)**

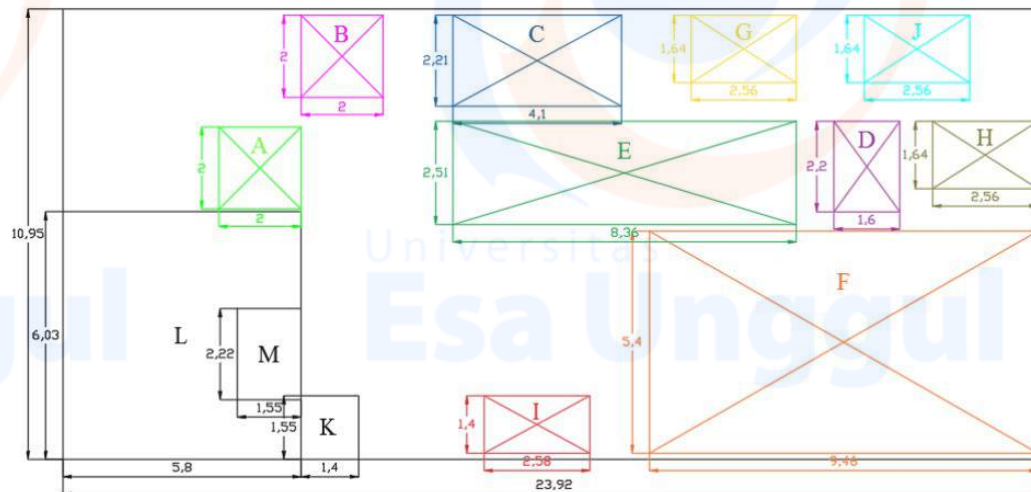

Warna	Kode	Keterangan
Hijau	A	Shipping Area
Pink	B	Receiving Area
Biru Tua	C	Area Mesin CNC
Ungu	D	Area Mesin Bor Radial
Hijau Tua	E	Area Mesin Milling
Orange	F	Area Mesin Bubut
Kuning	G	Grinding Area
Abu-Abu	H	Welding Area
Merah	I	Area Mesin Shaping
Biru	J	Cutting Area
Hitam	K	Toilet Lantai Produksi
Hitam	L	Kantor Lantai 1&2
Hitam	M	Toilet Kantor

**Layout Existing Divisi Machining PT. Hamdan Jaya Makmur**

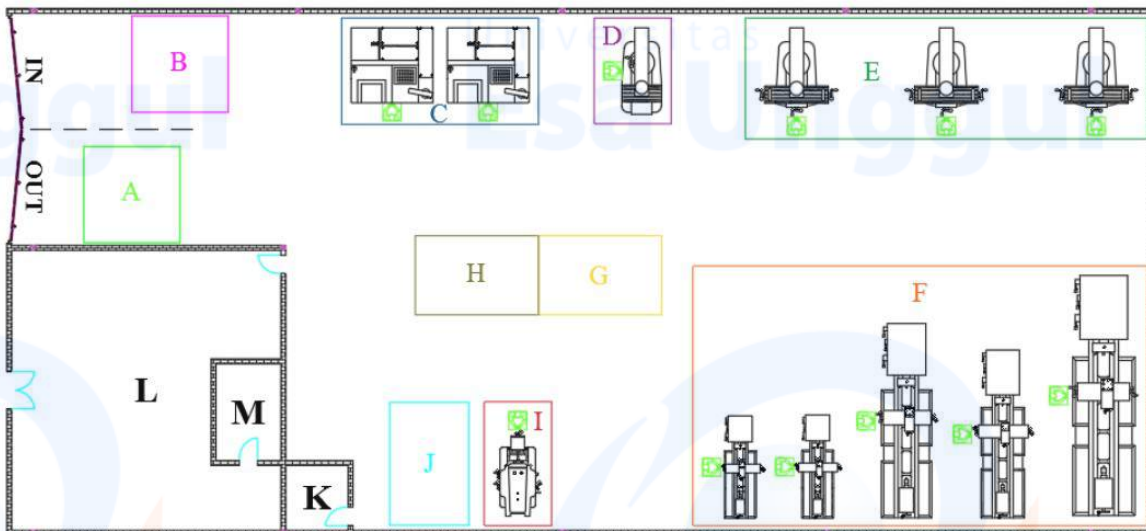

**Layout Modifikasi Divisi Machining PT. Hamdan Jaya Makmur**

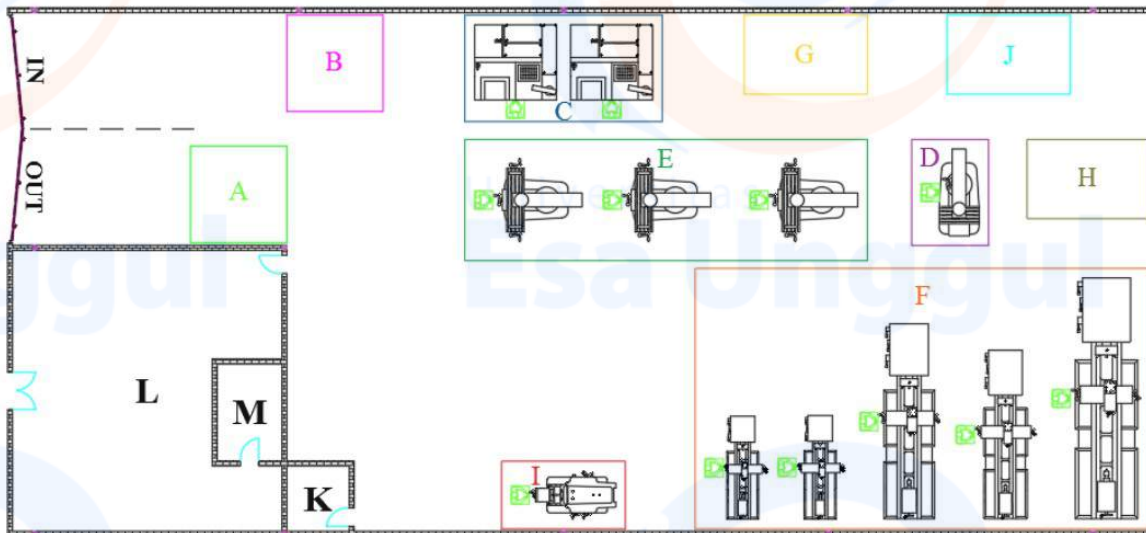

Warna	Kode	Keterangan
Hijau	A	Shipping Area
Pink	B	Receiving Area
Biru Tua	C	Area Mesin CNC
Ungu	D	Area Mesin Bor Radial
Hijau Tua	E	Area Mesin Milling
Orange	F	Area Mesin Bubut
Kuning	G	Grinding Area
Abu-Abu	H	Welding Area
Merah	I	Area Mesin Shaping
Biru	J	Cutting Area
Hitam	K	Toilet Lantai Produksi
Hitam	L	Kantor Lantai 1&2
Hitam	M	Toilet Kantor