

Lampiran 1

Tampilan Form Aplikasi



The screenshot shows a login window titled "Login Sistem Penjualan". It features three input fields: "Login ID" with the text "ramon", "Password" with masked characters "XXXXXXXX", and "Level" with a dropdown menu set to "ADMINISTRATOR". There are two buttons on the right: "Login" and "Close".

Form Login

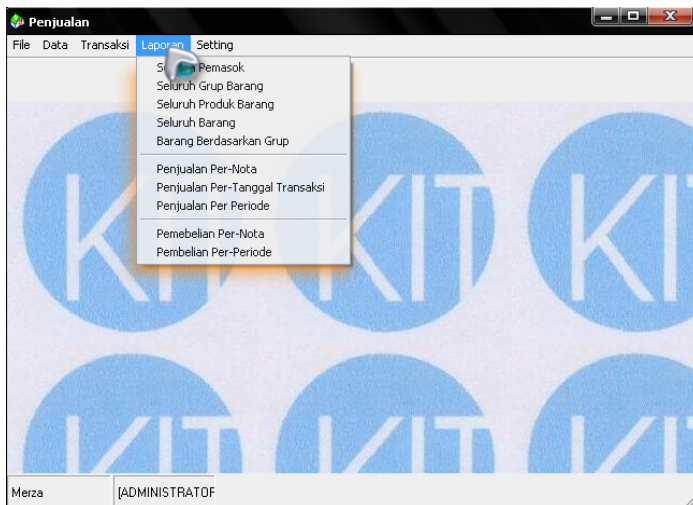

Form Menu Utama

MANAJEMEN DATA PELANGGAN

NO	KODE	NAMA PELANGGAN	NO. TELEPON	ALAMAT
1	PG001	UMUM	[]	
2	PG002	Bruce	[021]5589764	Banjar
3	PG003	Mamad	[021]55792823	Tangerang
4	PG004	Joe	[021]5503564	Bekasi

Kode Pelanggan: PG002

Nama Pelanggan: Bruce

Alamat: Banjar

No. Telepon: [021]5589764

Form Pelanggan

MANAJEMEN DATA PEMASOK

NO	KODE	NAMA PEMASOK	ALAMAT	KOTA	PROPINSI
1	PS001	PT. Dunia Properti	Jl. Pramuka Raya No.405	Jakarta	DKI Jakarta
2	PS002	PT. Cinta Abadi	Jl. Raya Tajur 216	Bogor	Jawa Barat
3	PS003	PT. Properti Group	Jl. Jend. A. Yani No. 90	Serang	Banten

Kode Pemasok: PS001

Nama Pemasok: PT. Dunia Properti

Alamat: Jl. Pramuka Raya No.405

Kota: Jakarta

Propinsi: DKI Jakarta

No. Telepon: [021]55731267

No. Fax: [021]55731267

Kontak Person: Badrun

Form Pemasok

MANAJEMEN GRUP PRODUK

NO	KODE	NAMA GRUP
1	KRS	KURSI
2	LMR	LEMARI
3	MTR	MATRAS
4	RJG	RANJANG

Kode Grup: Harus 3 digit

Nama Grup:

Form Grup Produk

MANAJEMEN PRODUK BARANG

NO	KODE	NAMA PRODUK
1	KRS.001	KURSI SOFA
2	KRS.002	KURSI SEKOLAH
3	KRS.003	KURSI KANTOR
4	LMR.001	LEMARI PAKAIAN
5	LMR.002	LEMARI SEPATU
6	MTR.001	MATRAS MEDIUM
7	MTR.002	MATRAS PREMIUM
8	MTR.003	MATRAS SUPERIOR
9	RJG.001	RANJANG MEDIUM
10	RJG.002	RANJANG PREMIUM

Kode Produk:

Data Grup:

Nama Produk:

Form Produk Barang

MANAJEMEN DATA BARANG

NO	KODE	PRODUK	NAMA BARANG	SATUAN	H BELI[Rp.]	H JUAL[Rp.]
1	KRS.001.001	KURSI SOFA	Kursi Sofa (OLYMPIC)	Set	20000	30000
2	KRS.001.002	KURSI SOFA	Kursi Sofa (COLUMBIA)	Set	40000	50000
3	KRS.001.003	KURSI SOFA	Kursi Sofa (standar)	Set	30000	40000
4	KRS.001.004	KURSI SOFA	Kursi Sofa Sudut	Set	60000	70000
5	KRS.002.001	KURSI SEKOLAH	Kursi Sekolah (standar)	Unit	15000	20000
6	KRS.002.002	KURSI SEKOLAH	Kursi Sekolah (standar)	Set	75000	85000
7	KRS.003.001	KURSI KANTOR	Kursi Kantor (standar)	Unit	45000	50000

Cari Nama :

Grup Barang

Produk Barang

Nama Barang

Satuan

Harga Beli

Harga Jual

Stok Barang

Kode Barang
KRS.001.001

Nilai

Save

Delete

Normal

Form Data Barang

CARI DATA BARANG

NO	KODE	JENIS	NAMA BARANG
1	RJG.001.001	RANJANG	Ranjang Medium (YUKI)
2	RJG.001.002	RANJANG	Ranjang Medium (OLYMPIC)
3	RJG.001.003	RANJANG	Ranjang Medium (COLUMBIA)
4	RJG.001.004	RANJANG	Ranjang Medium (standar)
5	RJG.003.001	RANJANG	Ranjang Superior (YUKI)
6	RJG.003.002	RANJANG	Ranjang Superior (OLYMPIC)
7	RJG.003.003	RANJANG	Ranjang Superior (COLUMBIA)

Search

Normal

Close

Form Cari Data Barang

== CARI STOK BARANG

NO	KODE	GRUP	NAMA BARANG	HARGA (R
1	LMR.001.001	LEMARI	Lemari Pakaian (OLYMPIC)	2
2	LMR.001.002	LEMARI	Lemari Pakaian (COLUMBIA)	3
3	LMR.002.001	LEMARI	Lemari Sepatu (standar)	3
4	LMR.001.003	LEMARI	Lemari Pakaian (standar)	2

Search

Normal

Close

lemari

Form Cari Stok Barang

== TRANSAKSI PENJUALAN

KODE	NAMA BARANG	HARGA (Rp)	JUMLAH	SUBTOTAL (Rp)
LMR.001.002	LEMARI PAKAIAN (COLUMBIA)	350000	3	1750000

Nomor Transaksi JL-0000007 Tanggal 27/09/2002

Kode Barang Cari

Nama Barang

Harga Jual (Rp) Pelanggan PG002

Jumlah Masuk Bruce

Sub Total (Rp)

New

Save

Cancel

Total Bayar Rp **1750000**

Uang Bayar Rp **500000**

Uang Kembali Rp **3250000**

Form Transaksi Penjualan

:: TRANSAKSI PEMBELIAN BARANG

KODE	NAMA BARANG	HARGA (Rp)	JUMLAH	SUBTOTAL (Rp)
KRS.001.004	KURSI SOFA SUDUT	500000	5	2500000

Kode Barang	Nama Barang	Harga (Rp)	Qty	Sub Total (Rp)
<input type="text" value=""/>	<input type="text" value="Caji"/>	<input type="text" value="0"/>	<input type="text" value=""/>	<input type="text" value=""/>

Nomer Masuk	<input type="text" value="BL-0000003"/>
Tanggal Masuk	<input type="text" value="27/09/2002"/>
Nama Pemasok	<input type="text" value="PS001"/> PT. Dunia Properti
Alamat Pemasok	<input type="text" value="Jl. Pramuka Raya No.405"/>

Total Harga Rp.

Form Transaksi Pembelian

:: MANAJEMEN PENGGUNA

USER ID	NAMA PEMILIK	ALAMAT
Ramon	Merza	Tangerang
Beno	Saepul	Perum

User ID	<input type="text" value="Ramon"/> > 3 digit
Password	<input type="text" value="#####"/>
Nama Pemilik	<input type="text" value="Merza"/>
Alamat	<input type="text" value="Tangerang"/>
Level	<input type="text" value="ADMINISTRATOR"/>

Form Pengguna

:: Laporan Barang Per Grup

Grup Barang MATRAS

Show

Cancel

Form Laporan Barang Per Grup

:: Laporan Penjualan Per Nota

NO	KODE	NAMA BARANG	HARGA JUAL	QTY	SUBTOTAL
1	LMR.001.002	Lemari Pakaian (COLUMBIA)	350000	5	1750000

Nomor Transaksi JL-0000007

Preview

Show

Exit

Form Laporan Penjualan Barang Per Nota

:: Laporan Penjualan Per-Tanggal Transaksi

NO	NO NOTA	TANGGAL	KODE	NAMA BARANG	HARGA JUAL	QTY	S
1	JL-0000007	27/09/2002	LMR.001.002	Lemari Pakaian (COLUMBIA)	350000	5	

Tanggal Transaksi:

Preview Show Exit

Form Laporan Penjualan Per Tanggal Transaksi

:: LAPORAN PENJUALAN PER-PERIODE

NO	NO NOTA	TANGGAL	KODE	NAMA BARANG	HARGA JUAL	QT
1	JL-0000006	26/09/2002	KRS.003.002	Kursi Kantor (standar)	2000000	
2	JL-0000007	27/09/2002	LMR.001.002	Lemari Pakaian (COLUMBIA)	350000	

Tanggal Awal:

Tanggal Akhir:

Preview Show Exit

Form Laporan Penjualan Per Periode

:: Laporan Pembelian Per-Nomor Masuk

NO	KODE	NAMA BARANG	HARGA BELI	QTY	SUBTOTAL
1	KRS.001.004	Kursi Sofa Sudut	500000	5	2500000

Nomor Transaksi

Nama Pemasok

Form Laporan Pembelian Per Nomor Masuk

:: Laporan Pembelian Per-Periode

NO	NO NOTA	TANGGAL	KODE	NAMA BARANG	HARGA JUAL
1	BL-0000003	27/09/2002	KRS.001.004	Kursi Sofa Sudut	500000
2	BL-0000004	27/09/2002	LMR.002.001	Lemari Sepatu (standar)	60000

Tanggal Awal

Tanggal Akhir

Form Laporan Pembelian Per Periode

:: CETAK NOTA TRANSAKSI PENJUALAN

CV. KERAMIK INDAH TANGERANG

TOKO FURNITURE LENGKAP
 Jl.Delta Raya 1 No.291, Cibodas, Jatiuwung - Tangerang :
 Jumat, 27/09/2002

No Transaksi: JL-0000007

No. Kode	Nama	Qty	Harga	Total
1.	LMR.001.002 Lemari Pakaian (COLUMBIA)	5	350.000	1.750.000

Total Jenis Barang = 1 ; Total Besar Uang = 1.750.000

Total : 1.750.000
 Bayar : 5.000.000
 Kembali : 3.250.000

** TERIMA KASIH **

Save Print Exit

Form Nota Transaksi Penjualan

Laporan Seluruh Pemasok

Zoom 100%

Laporan Seluruh Pemasok

Tanggal Cetak : 27 September 2002

Kode	Nama Pemasok	Alamat	Nomor Telepon	Kontak P
PS001	PT. Dunia Properti	Jl. Pramuka Raya No.405	[021_]_55731267	Badrun
PS002	PT. Cinta Abadi	Jl. Raya Tajur 216	[0251]-3478158_	Rohmat
PS003	PT. Properti Group	Jl. Jend. A. Yani No. 90	[0254]-4462381_	Wwit

Pages: 1

Laporan Pemasok

The screenshot shows a window titled "Laporan Seluruh Grup Produk" with a zoom level of 100%. The main content is a table with the following data:

Daftar Seluruh Grup Produk	
Tanggal Cetak : 27 September 2002	
Kode Grup	Nama Grup
KRS	KURSI
LMR	LEMARI
MTR	MATRAS
RJG	RANJANG

The window also shows a page navigation bar at the bottom with "Pages: 1" and navigation icons.

Laporan Grup Produk

The screenshot shows a window titled "Laporan Seluruh Produk Barang" with a zoom level of 100%. The main content is a table with the following data:

Daftar Seluruh Produk Barang	
Tanggal Cetak : 27 September 2002	
Kode Produk	Nama Produk
KRS.001	KURSI SOFA
KRS.002	KURSI SEKOLAH
KRS.003	KURSI KANTOR
LMR.001	LEMARI PAKAIAN
LMR.002	LEMARI SEPATU
MTR.001	MATRAS MEDIUM
MTR.002	MATRAS PREMIUM
MTR.003	MATRAS SUPERIOR
RJG.001	RANJANG MEDIUM
RJG.002	RANJANG PREMIUM
RJG.003	RANJANG SUPERIOR

The window also shows a page navigation bar at the bottom with "Pages: 1" and navigation icons.

Laporan Produk Barang

Daftar Seluruh Barang

Zoom 100%

Laporan Seluruh Barang

Tanggal Cetak : 27 September 2002

KODE	NAMA BARANG	GRUP BARANG	HARGA BARANG	STOK
KRS.001.001	Kursi Sofa (OLYMPIC)	KURSI	Rp 30,000	10
KRS.001.002	Kursi Sofa (COLUMBIA)	KURSI	Rp 50,000	10
KRS.001.003	Kursi Sofa (standar)	KURSI	Rp 40,000	10
LMR.001.001	Lemari Pakaian (OLYMPIC)	LEMARI	Rp 250,000	10
LMR.001.002	Lemari Pakaian (COLUMBIA)	LEMARI	Rp 350,000	10
LMR.002.001	Lemari Sepatu (standar)	LEMARI	Rp 55,000	5
LMR.001.003	Lemari Pakaian (standar)	LEMARI	Rp 200,000	10
MTR.001.001	Matras Medium (YUKI)	MATRAS	Rp 200,000	10
MTR.001.002	Matras Medium (OLYMPIC)	MATRAS	Rp 5,000,000	10
MTR.001.003	Matras Medium (COLUMBIA)	MATRAS	Rp 450,000	10
KRS.001.004	Kursi Sofa Sduit	KURSI	Rp 600,000	15
KRS.002.001	Kursi Sekolah (standar)	KURSI	Rp 20,000	30
KRS.002.002	Kursi Sekolah (standar)	KURSI	Rp 85,000	10
KRS.003.001	Kursi Kantor (satandar)	KURSI	Rp 50,000	30
KRS.003.002	Kursi Kantor (standar)	KURSI	Rp 250,000	10
MTR.001.004	Matras Medium (standar)	MATRAS	Rp 125,000	10
MTR.002.001	Matras Premium (YUKI)	MATRAS	Rp 250,000	10
MTR.002.002	Matras Premium (OLYMPIC)	MATRAS	Rp 600,000	10
MTR.002.003	Matras Premium (COLUMBIA)	MATRAS	Rp 850,000	10
MTR.003.001	Matras Superior (YUKI)	MATRAS	Rp 300,000	10
MTR.003.002	Matras Superior (OLYMPIC)	MATRAS	Rp 650,000	10

Pages: 1

Laporan Seluruh Barang

Laporan Barang Berdasarkan Grup

Zoom 100%

Laporan Barang Berdasarkan Grup

Tanggal Cetak : 27 September 2002

GRUP PRODUK : MATRAS

KODE	NAMA BARANG	HARGA BELI	HARGA JUAL	STOK
MTR.001.001	Matras Medium (YUKI)	Rp 100,000	200000	10
MTR.001.002	Matras Medium (OLYMPIC)	Rp 400,000	5000000	10
MTR.001.003	Matras Medium (COLUMBIA)	Rp 400,000	450000	10
MTR.001.004	Matras Medium (standar)	Rp 90,000	125000	10
MTR.002.001	Matras Premium (YUKI)	Rp 150,000	250000	10
MTR.002.002	Matras Premium (OLYMPIC)	Rp 500,000	600000	10
MTR.002.003	Matras Premium (COLUMBIA)	Rp 500,000	650000	10
MTR.003.001	Matras Superior (YUKI)	Rp 200,000	300000	10
MTR.003.002	Matras Superior (OLYMPIC)	Rp 600,000	650000	10
MTR.003.003	Matras Superior (COLUMBIA)	Rp 600,000	700000	10

Pages: 1

Laporan Barang Per Grup

LAPORAN PENJUALAN PER-NOTA

Zoom 100%

Laporan Penjualan Per-Nota

TANGGAL CETAK : 27 September 2002

NO TRANSAKSI : JL-0000007

KODE	NAMA BARANG	HARGA JUAL	QTY	SUBTOTAL
LMR.001.002	Lemari Pakaian (COLUMBIA)	Rp 350,000	5	Rp 1,750,000

Pages: 1

Laporan Penjualan Per Nota

LAPORAN PENJUALAN PER-TANGGAL

Zoom 100%

Laporan Penjualan Per-Tanggal

Tanggal Cetak : 27 September 2002

Tanggal Transaksi : 27 September 2002

NO NOTA	TANGGAL	KODE	NAMA BARANG	HARGA JUAL	QTY	SUBTOTAL
JL-0000007	27-Sep-2002	LMR.001.002	Lemari Pakaian (COLUMBIA)	Rp 350,000	5	Rp 1,750,000

Pages: 1

Laporan Penjualan Per Tanggal

LAPORAN PENJUALAN PER-PERIODE

Zoom: 100%

Laporan Penjualan Per-Periode

Tanggal Cetak : 27 September 2002

Periode Transaksi : 14 Februari 2002 S.D 27 September 2002

NO NOTA	TANGGAL	KODE	NAMA BARANG	HARGA JUAL	QTY	SUBTOTAL
JL-0000006	26-Sep-2002	KRS.003.002	Kursi Kantor (standar)	Rp 2,000,000	2	Rp 4,000,000
JL-0000007	27-Sep-2002	LMR.001.002	Lemari Pakaian (COLUMBIA)	Rp 350,000	5	Rp 1,750,000

Pages: 1

Laporan Penjualan Per Periode

LAPORAN PEMBELIAN PER-NOTA

Zoom: 100%

Laporan Pembelian Per-Nota

NO TRANSAKSI : BL-0000003

TANGGAL : 27 September 2002

NAMA PEMASOK : PT. Dunia Properti

ALAMAT : Jl. Pramuka Raya No.405

KODE	NAMA BARANG	HARGA BELI	QTY	SUBTOTAL
KRS.001.004	Kursi Sofa Sudut	Rp 500,000	5	Rp 2,500,000

Pages: 1

Laporan Pembelian Per Nota

LAPORAN PEMBELIAN PER PERIODE

Zoom 100%

Laporan Pembelian Barang Per-Periode

PERIODE : 27 September 2002
TANGGAL CETAK : 14 Februari 2002 S.D 27 September 2002

NO NOTA	TANGGAL	KODE	NAMA BARANG	HARGA BELI	JUMLAH
BL-0000003	27-Sep-2002	KRS.001.004	Kursi Sofa Sudut	Rp 500,000	5
BL-0000004	27-Sep-2002	LMR.002.001	Lemari Sepatu (standar)	Rp 60,000	4

Pages: 1

Laporan Pembelian Per Periode

Lampiran 2

a. Sequence diagram login

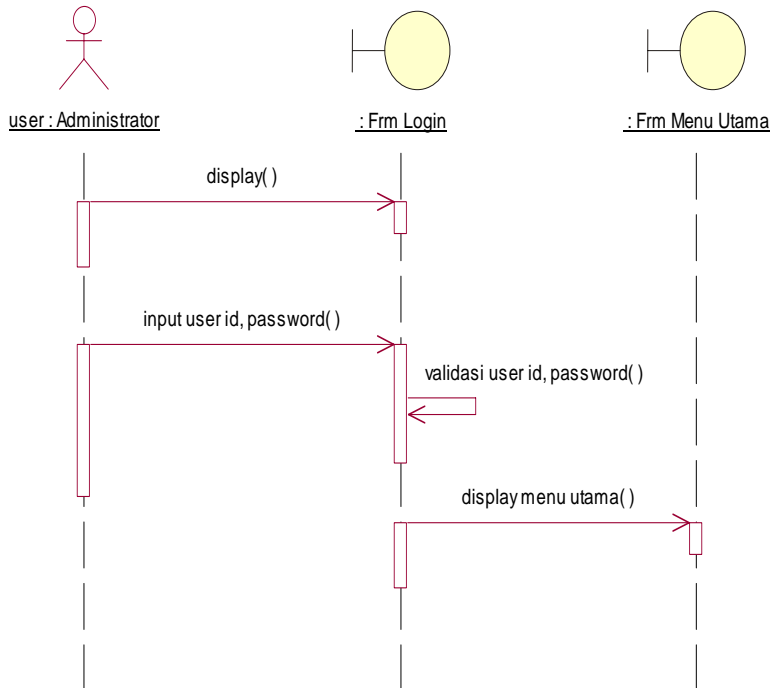

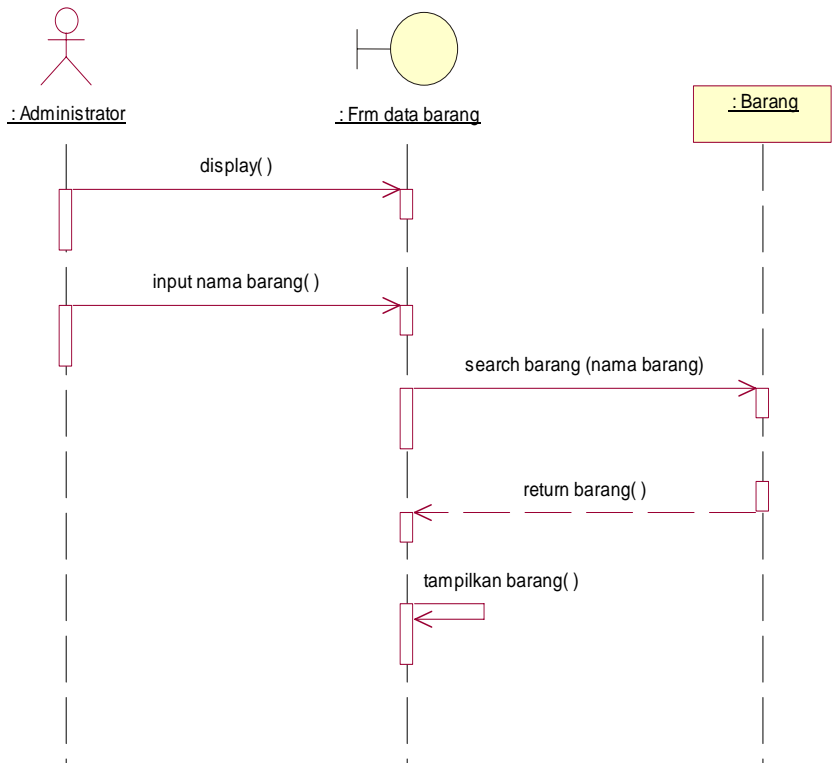
b. Sequence diagram cari data barang

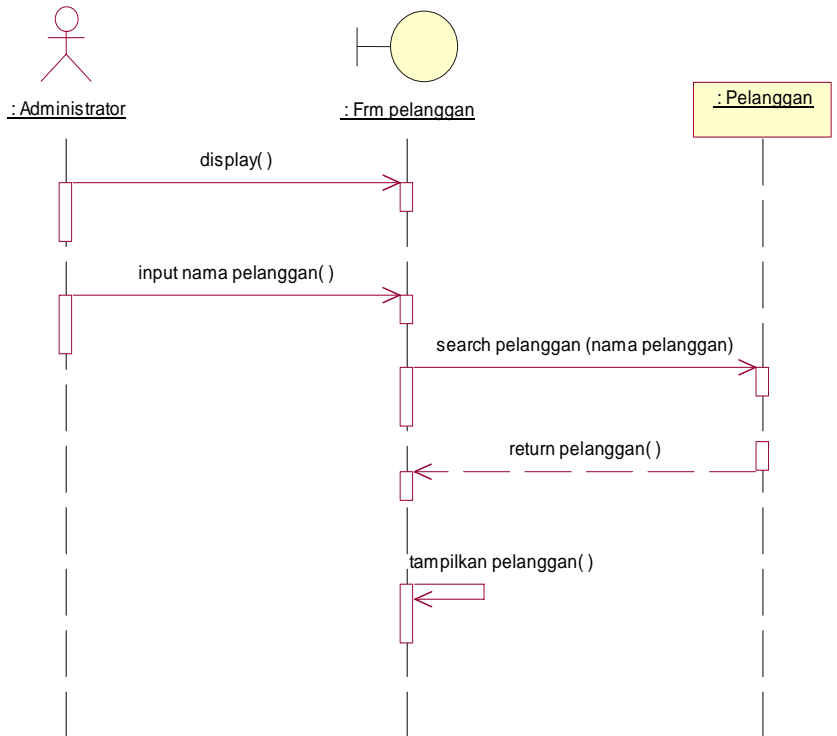
c. Sequence diagram cari data pelanggan

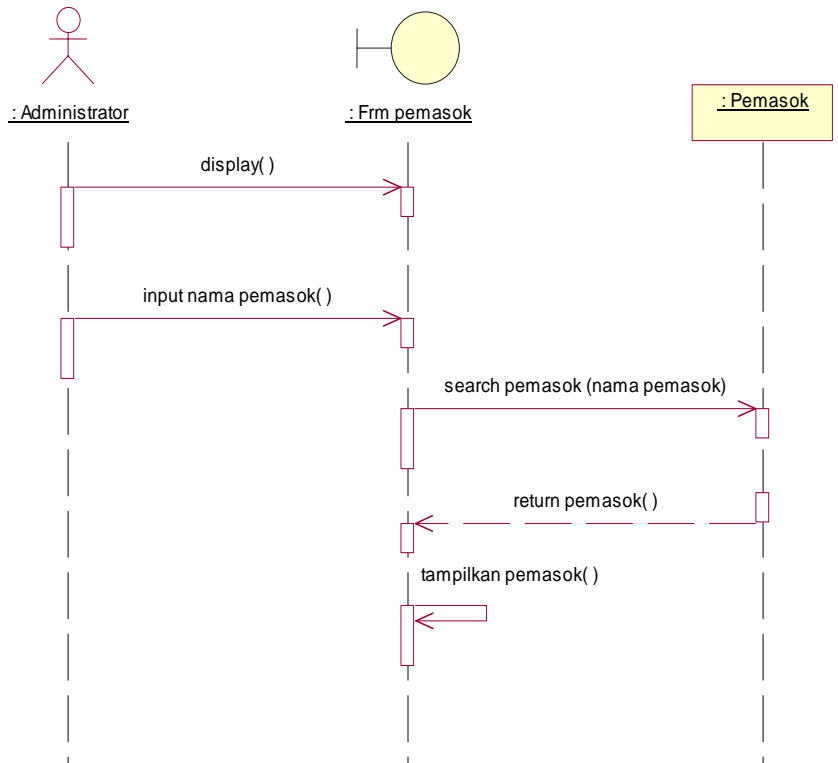
d. Sequence diagram cari data pemasok

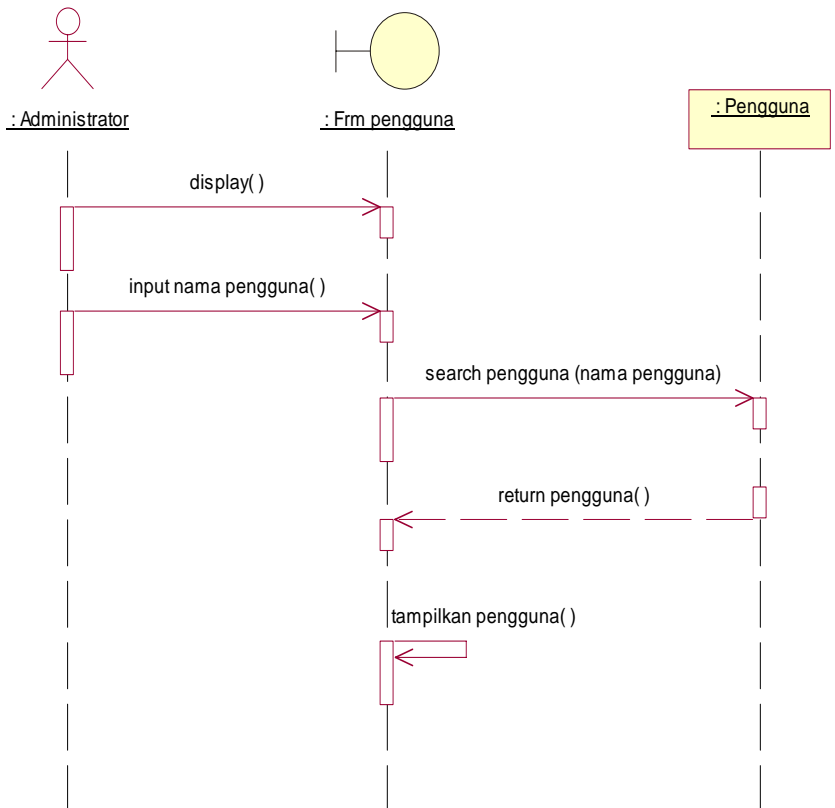
e. Sequence diagram cari data pengguna

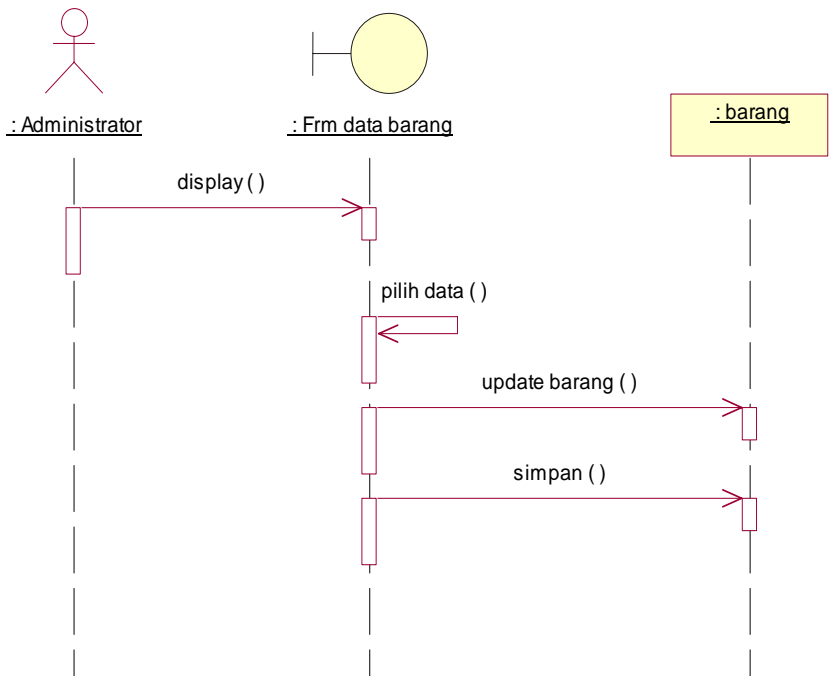
f. Sequence diagram edit data barang

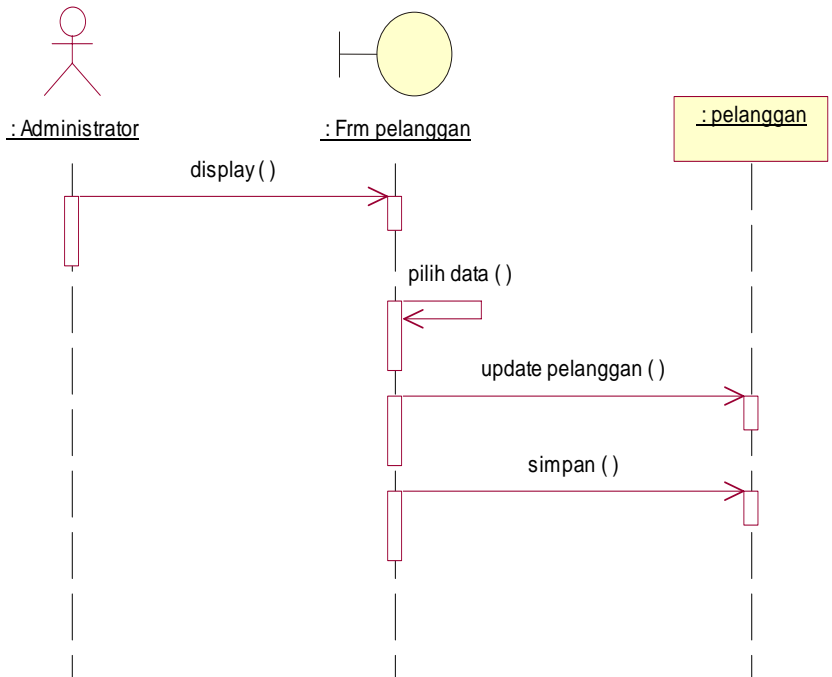
g. Sequence diagram edit data pelanggan

h. Sequence diagram edit data pemasok

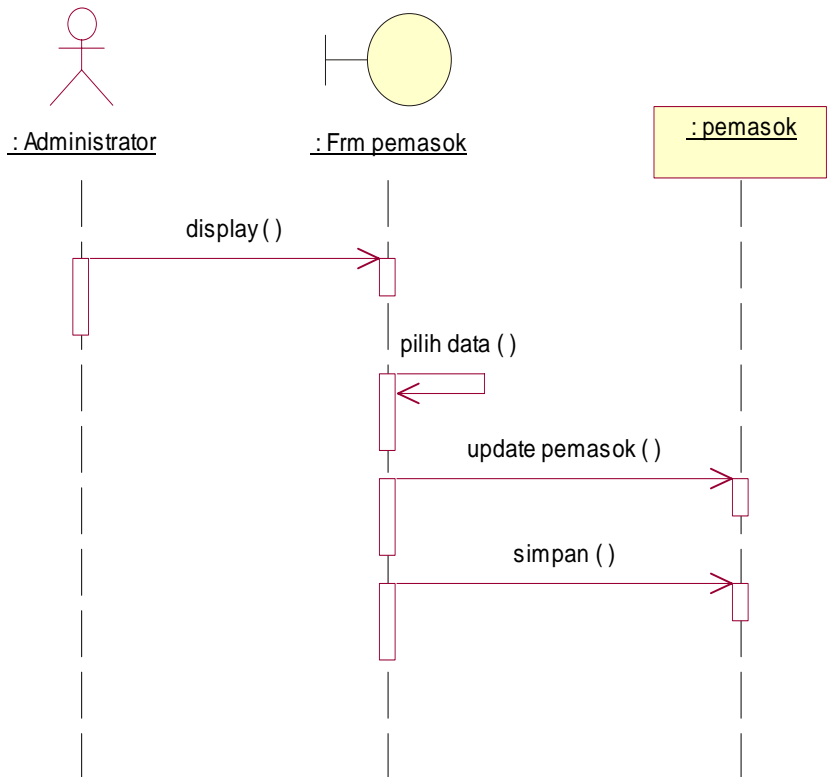

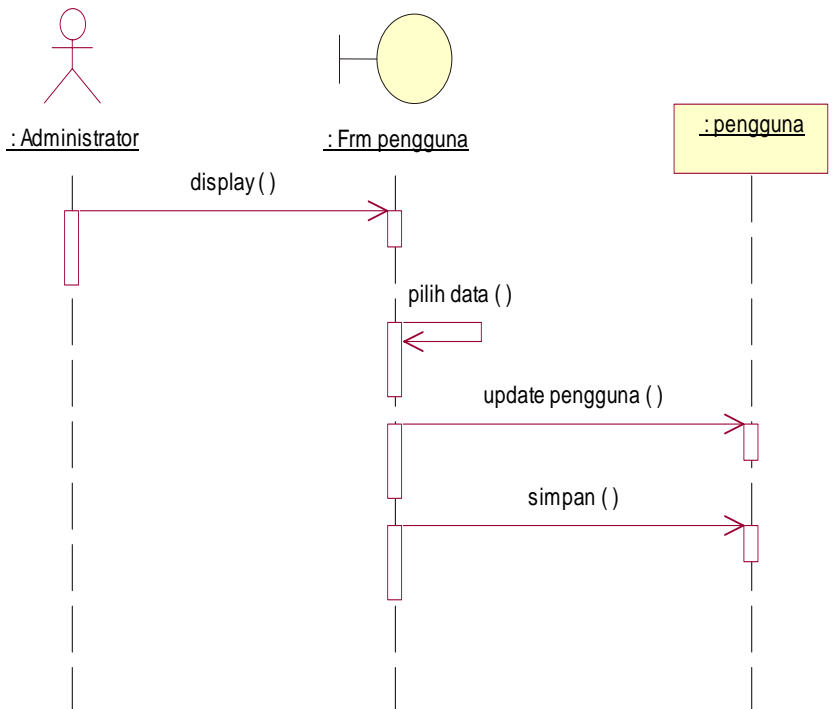
i. Sequence diagram edit data pengguna

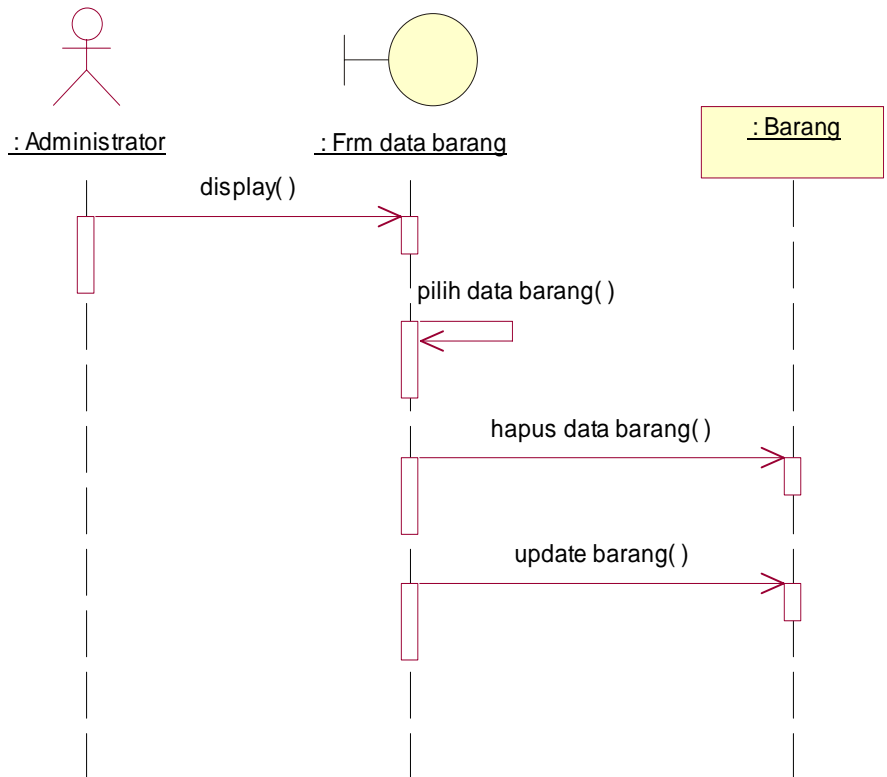
j. Sequence diagram hapus data barang

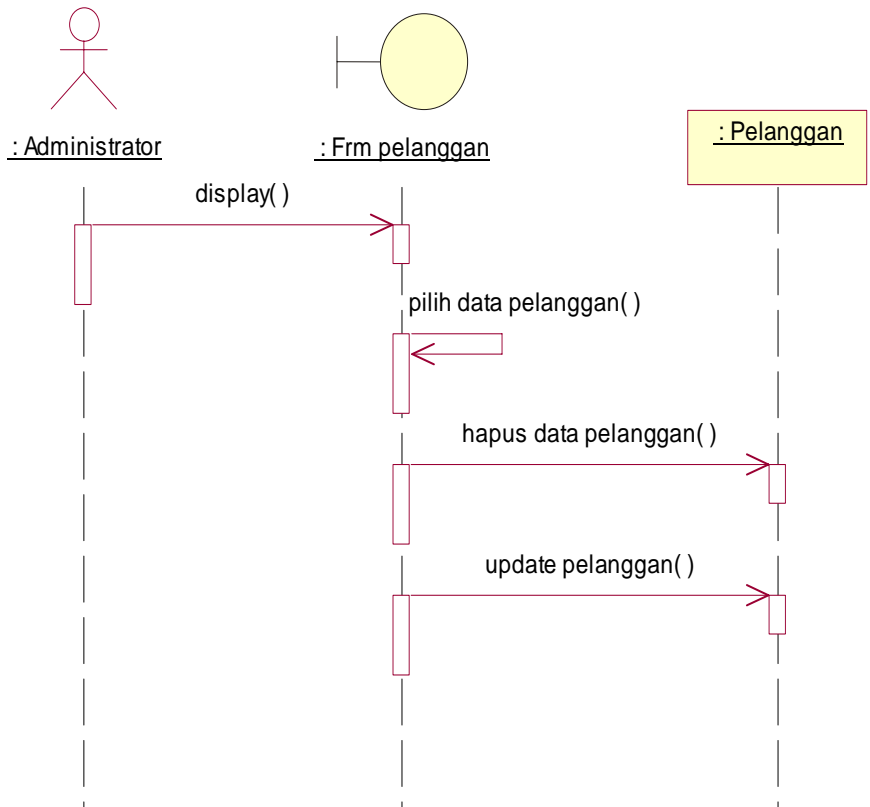
k. Sequence diagram hapus data pelanggan

I. Sequence diagram hapus data pemasok

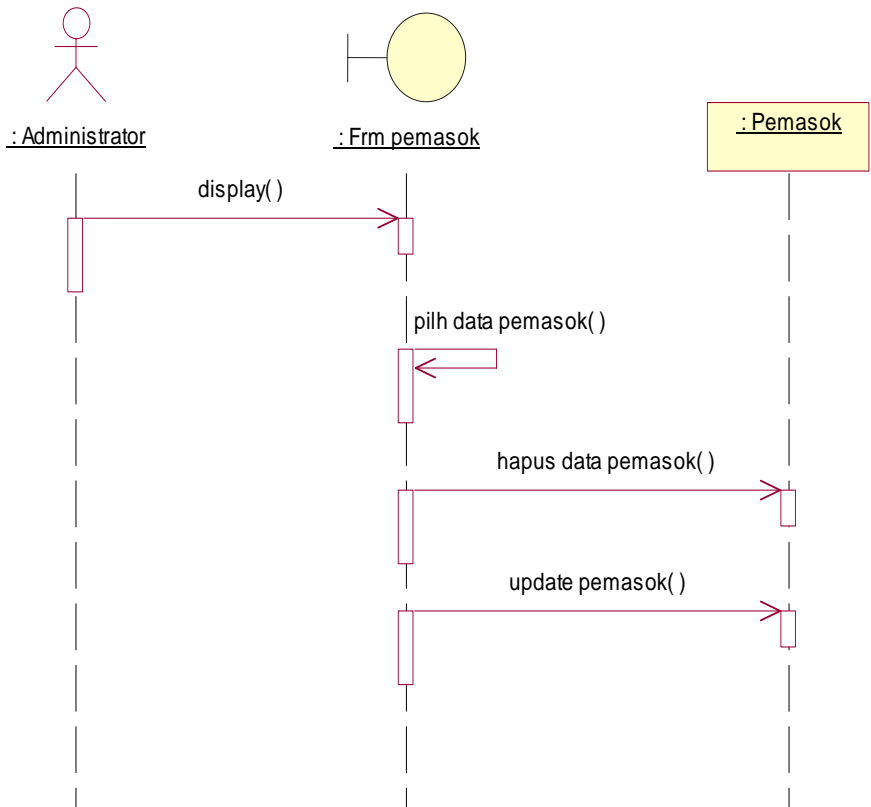

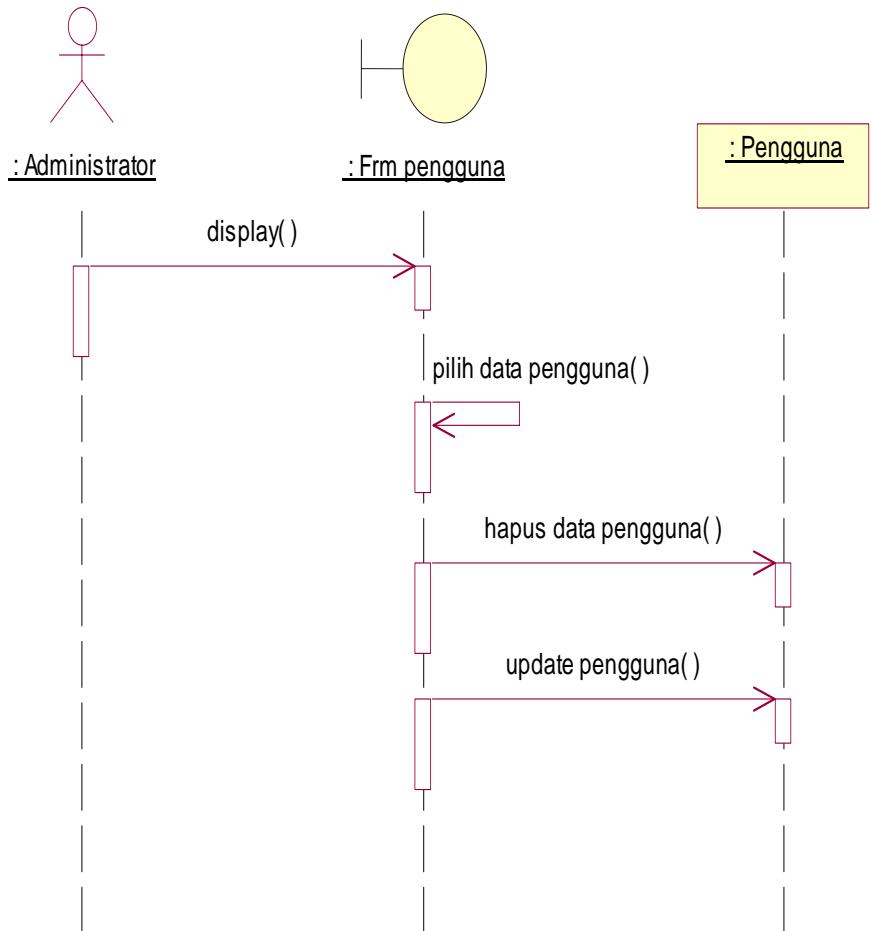
m. Sequence diagram hapus data pengguna

n. Sequence diagram input data barang

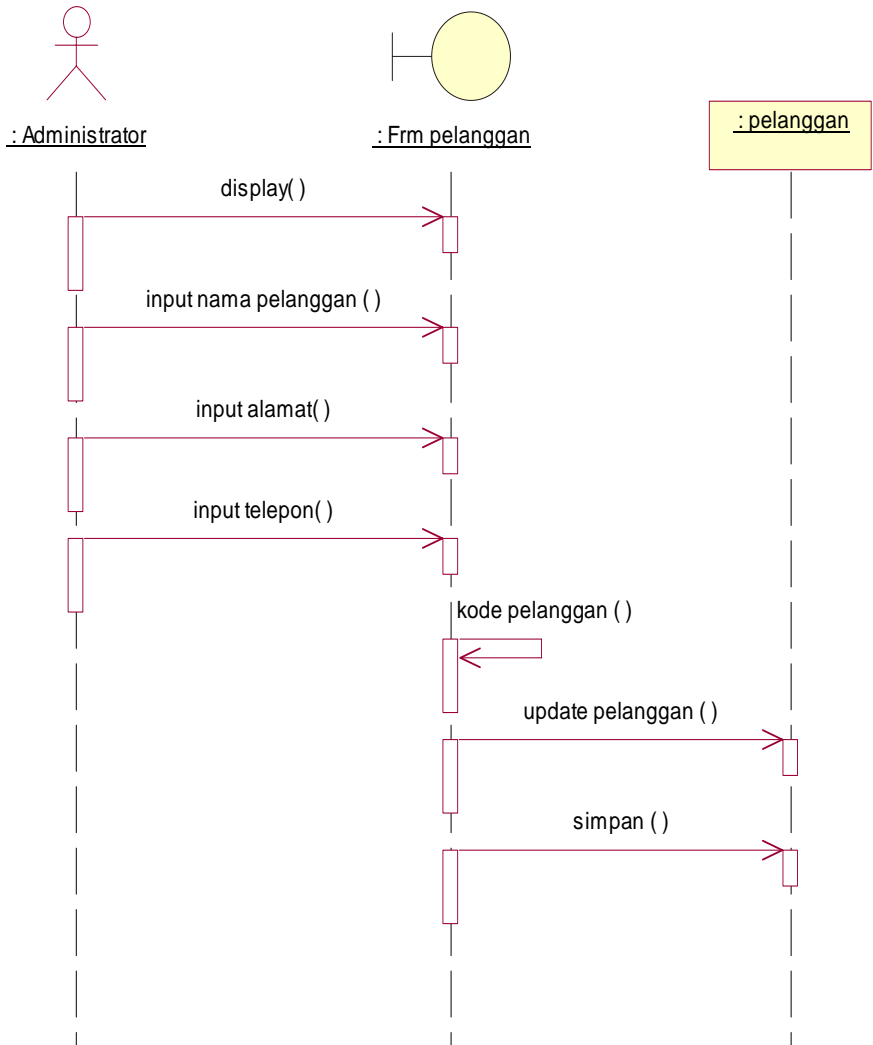
o. Sequence diagram input data pelanggan

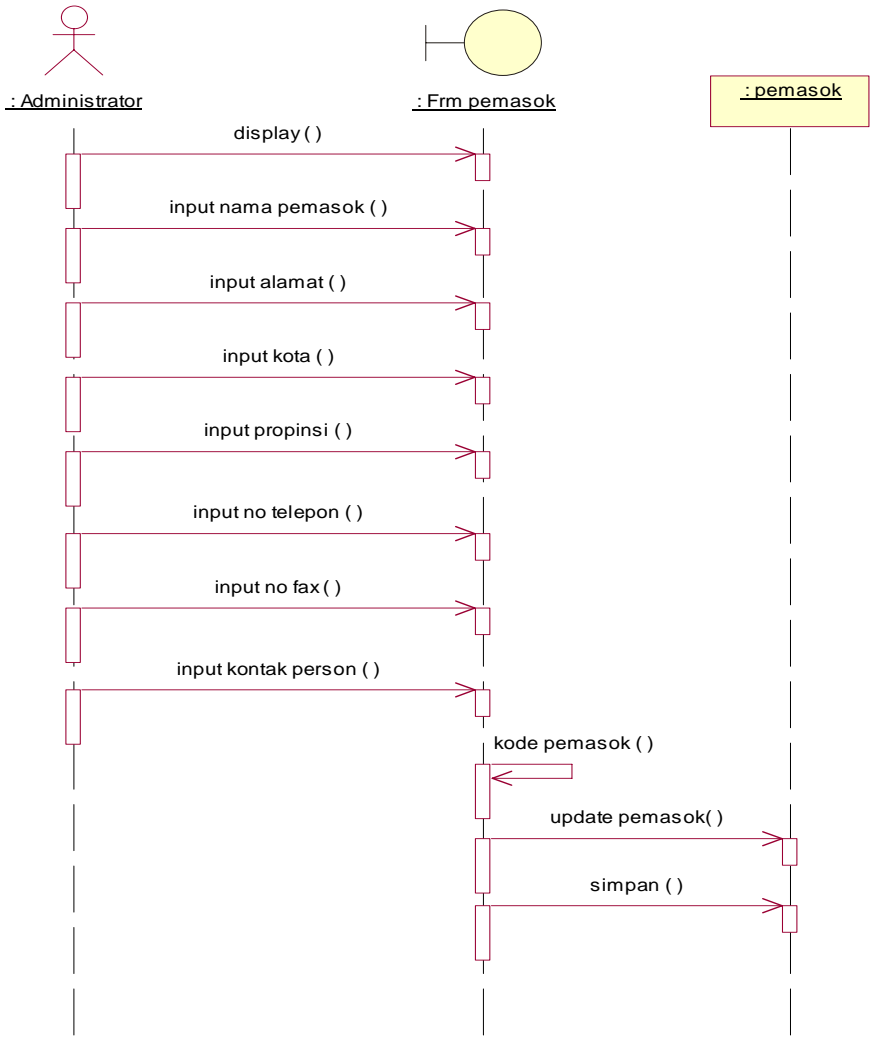
p. Sequence diagram input data pemasok

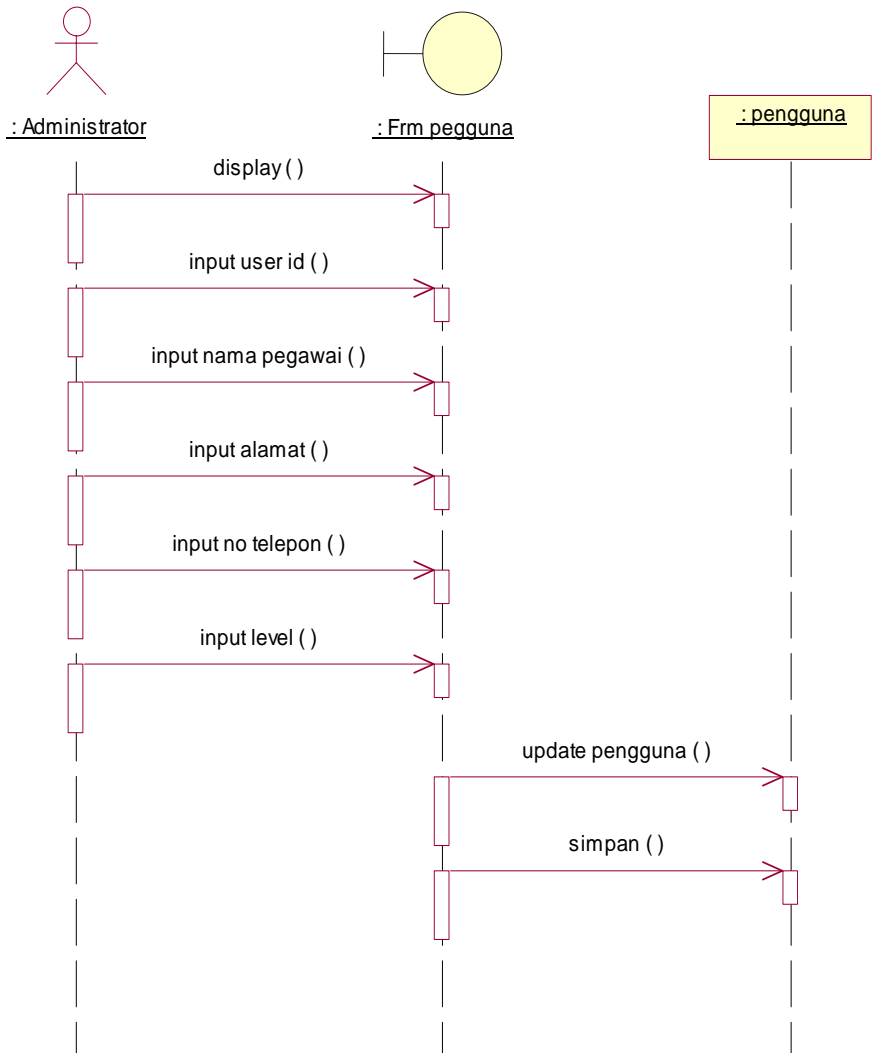
q. Sequence diagram input data pengguna

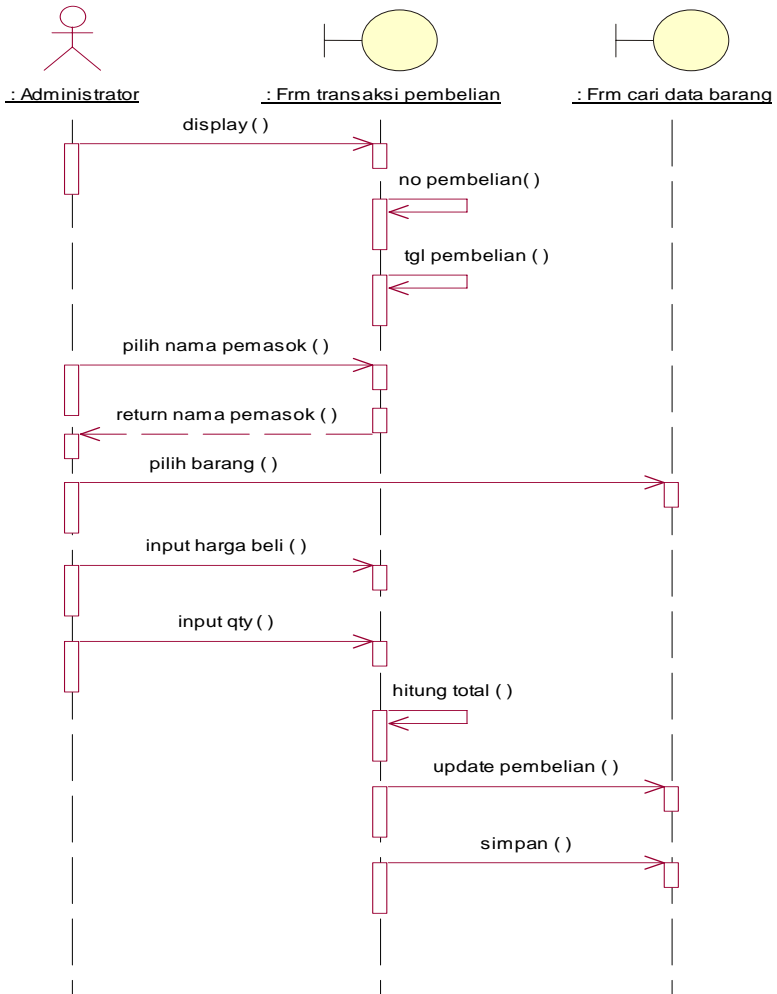
r. Sequence diagram input pembelian

Lampiran 3

a. Communication diagram login

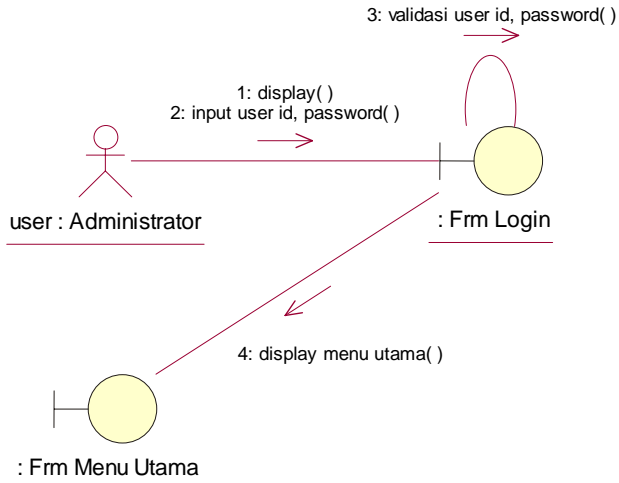

b. Communication diagram cari data barang

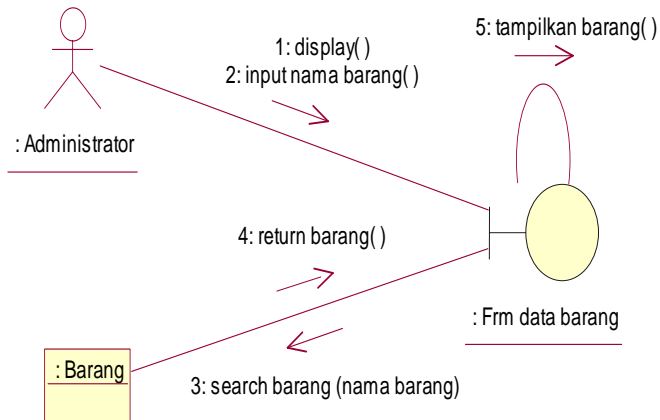

c. Communication diagram cari data pelanggan

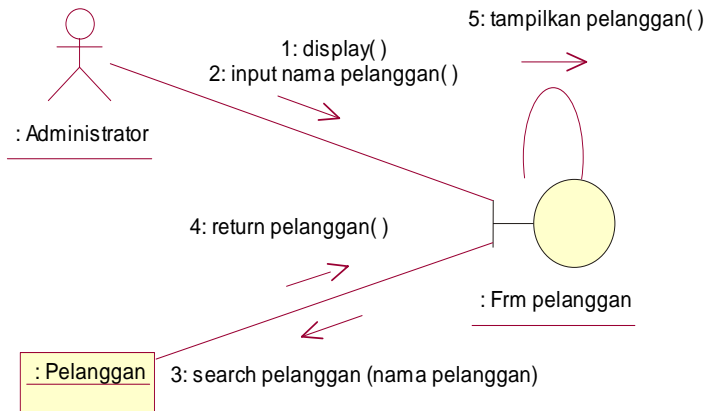

d. Communication diagram cari data pemasok

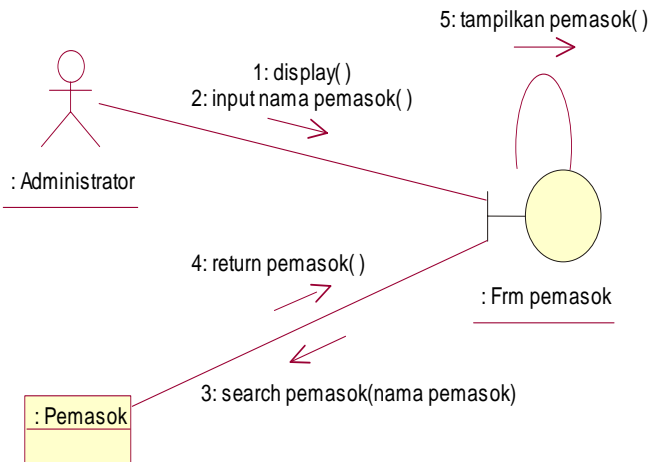

e. Communication diagram cari data pengguna

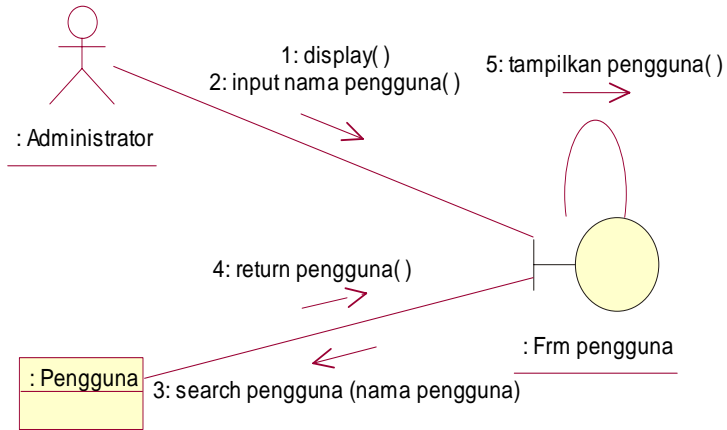

f. Communication diagram edit data barang

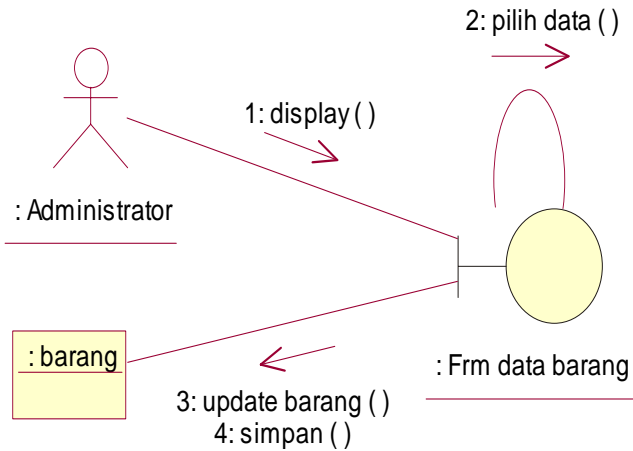

g. Communication diagram edit data pelanggan

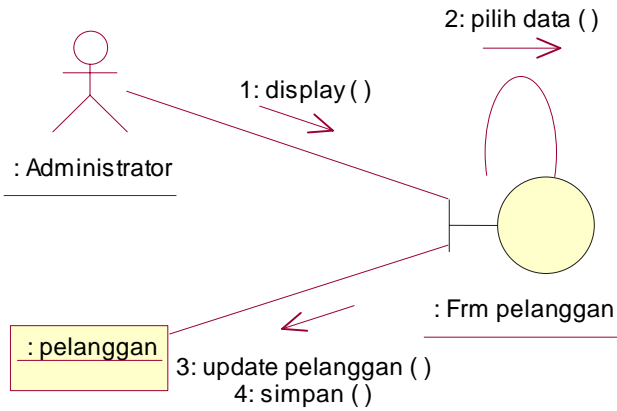

h. Communication diagram edit data pemasok

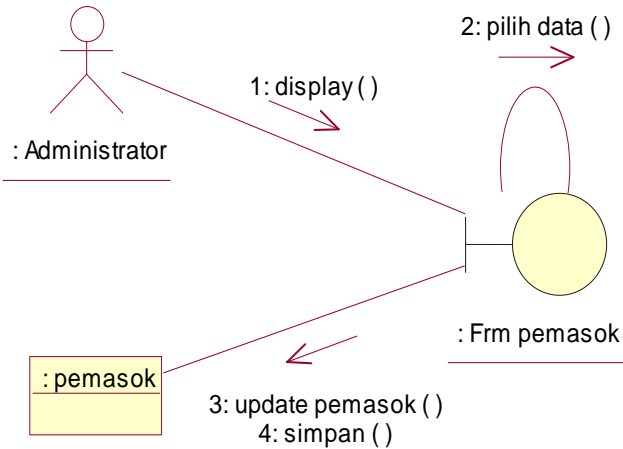

i. Communication diagram edit data pengguna

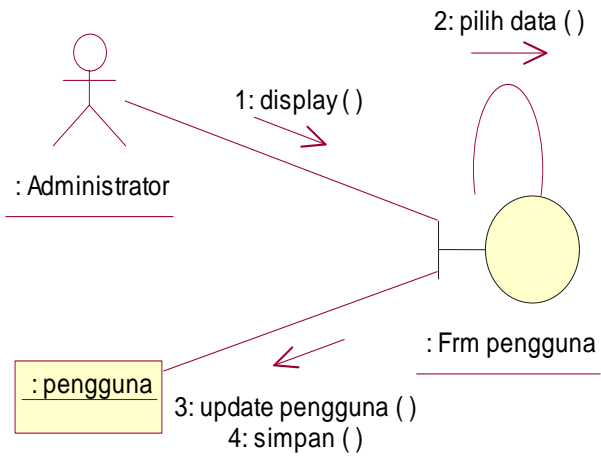

j. Communication diagram hapus data barang

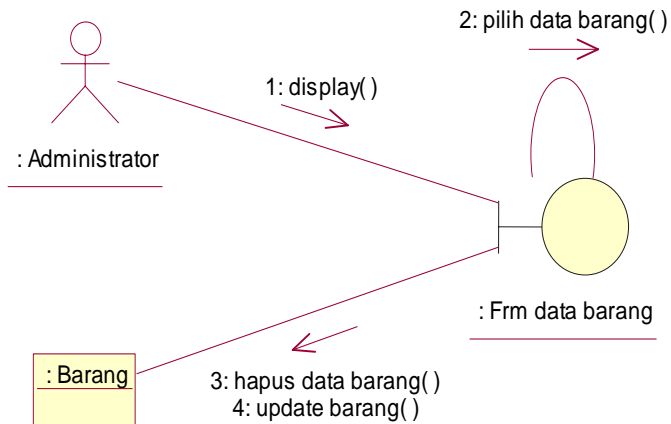

k. Communication diagram hapus data pelanggan

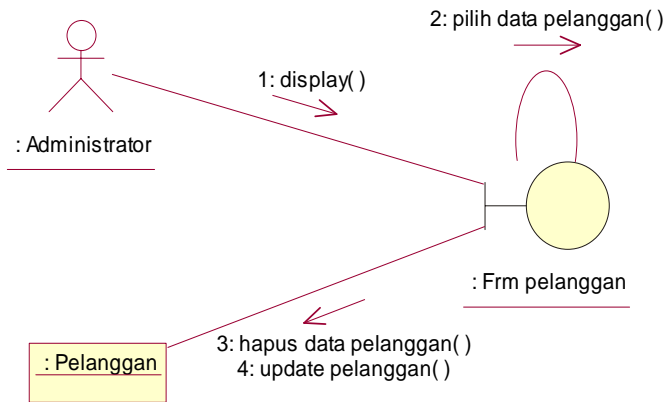

l. Communication diagram hapus data pemasok

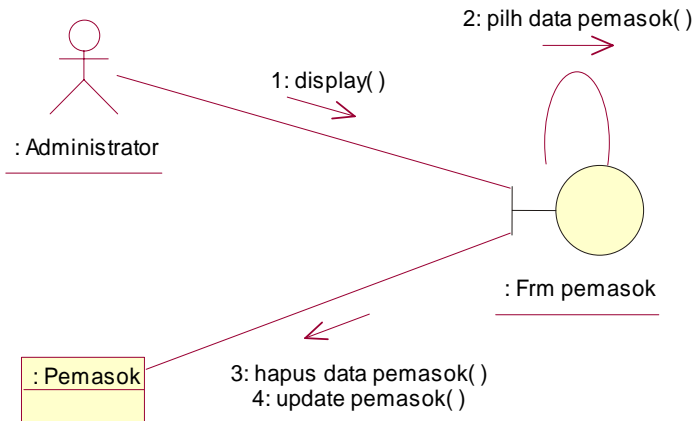

m. Communication diagram hapus data pengguna

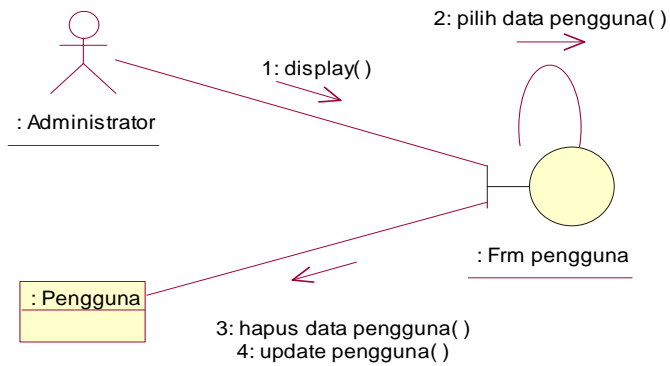

n. Communication diagram input data barang

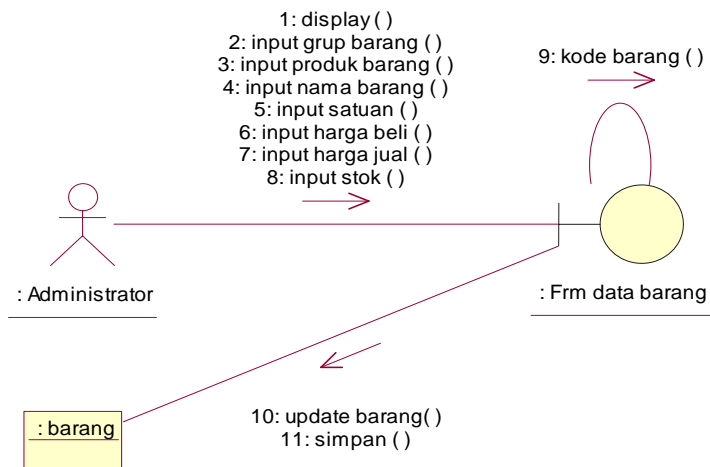

o. Communication diagram input data pelanggan

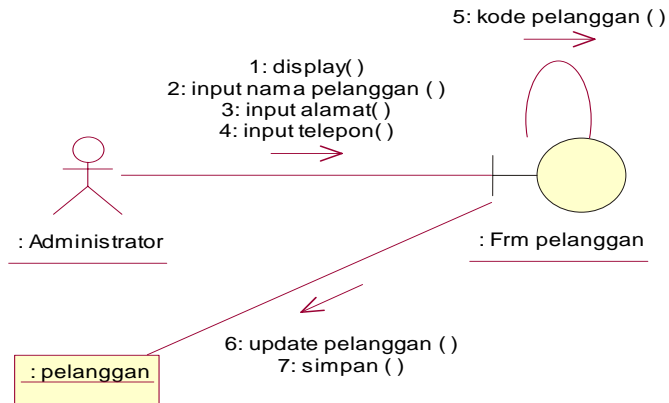

p. Communication diagram input data pemasok

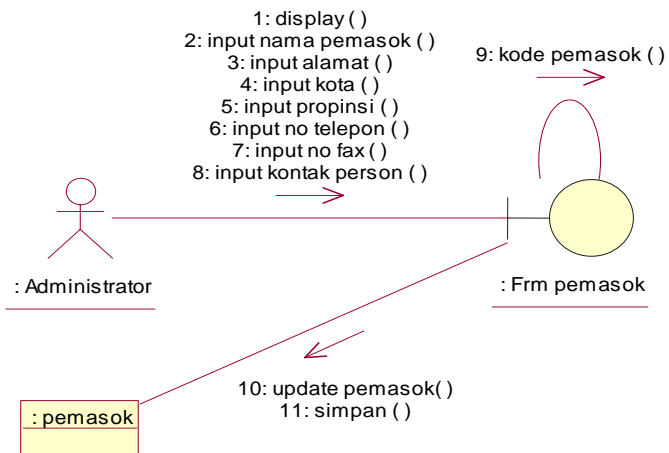

q. Communication diagram input data pengguna

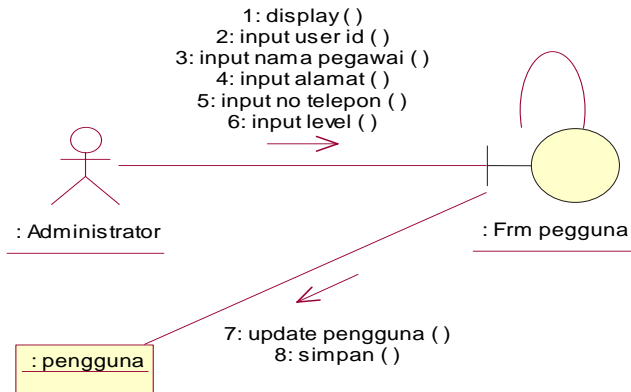

r. Communication diagram input pembelian

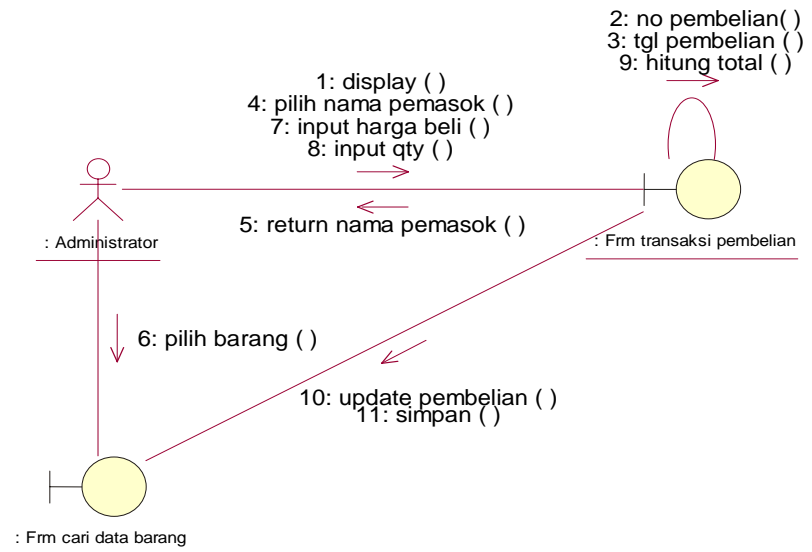

Lampiran 4

a. Statechart diagram cari data barang

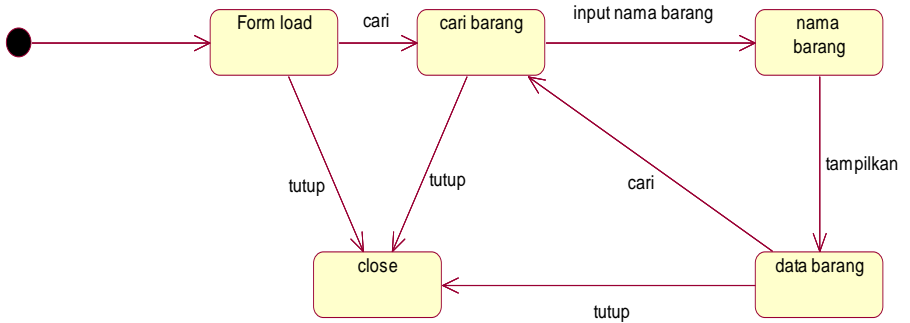

b. Statechart diagram cari data pelanggan

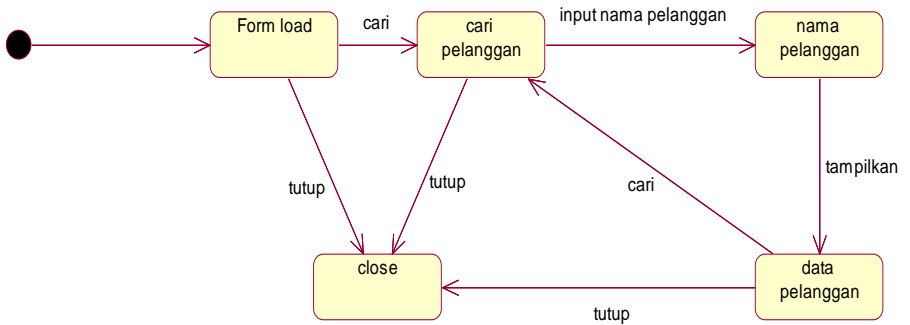

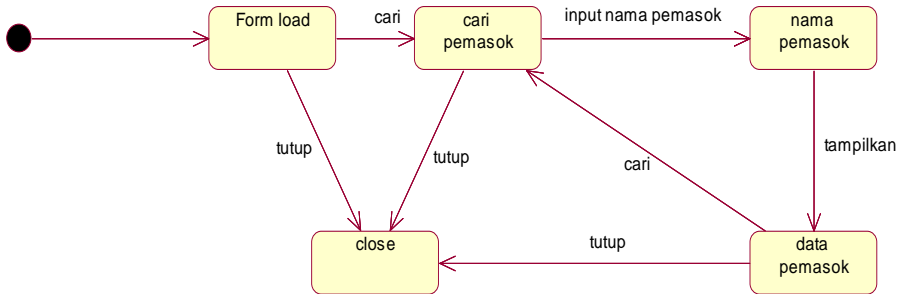
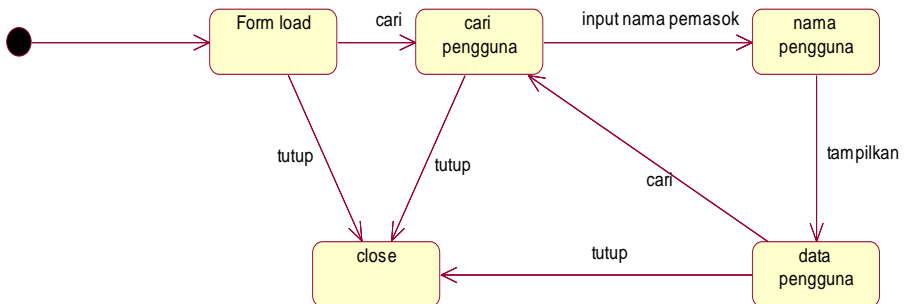
c. Statechart diagram cari data pemasok**d. Statechart diagram cari data pengguna**

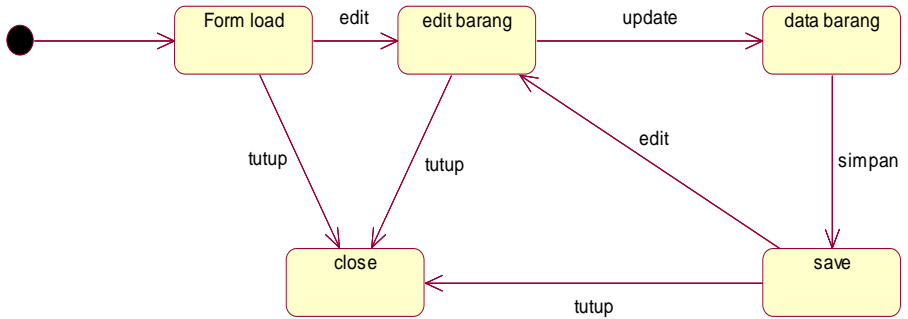
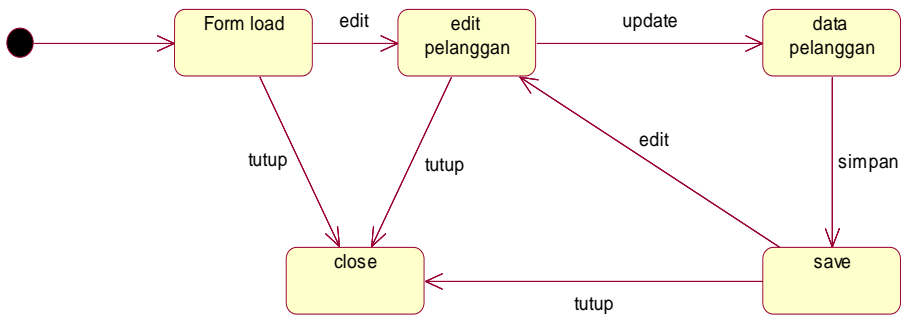
e. Statechart diagram edit data barang**f. Statechart diagram edit data pelanggan**

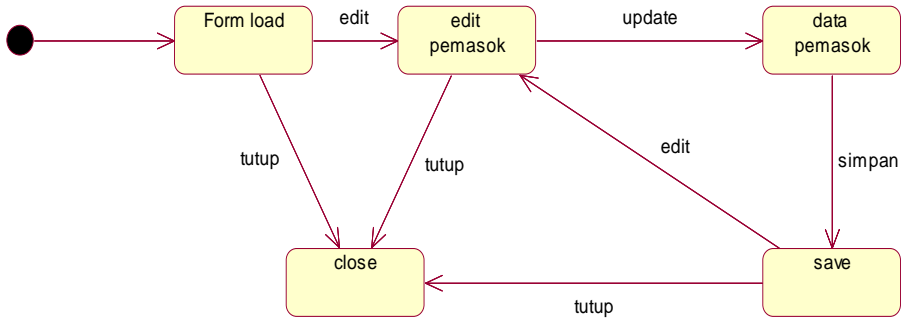
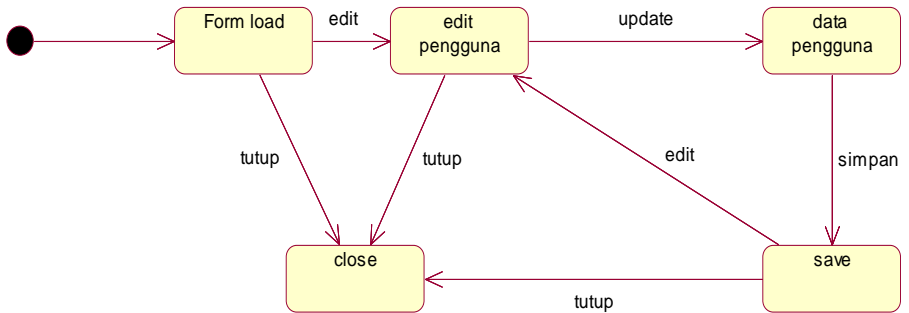
g. Statechart diagram edit data pemasok**h. Statechart diagram edit data pengguna**

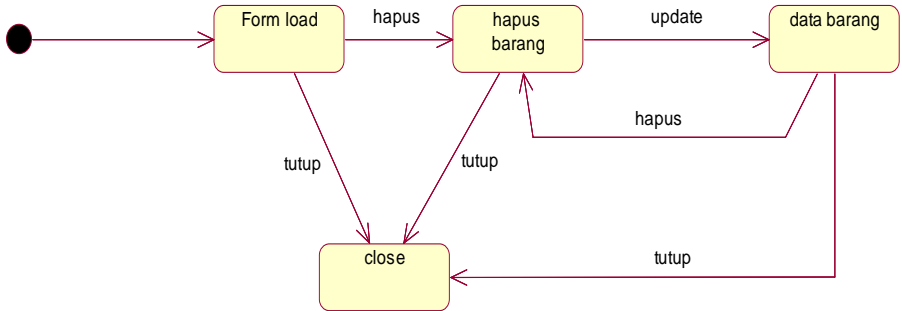
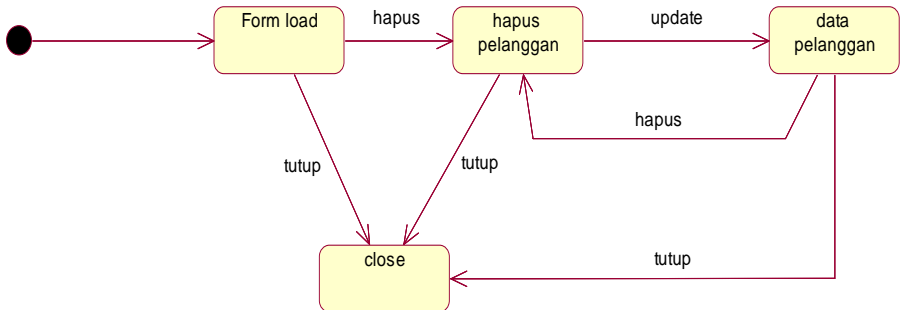
i. Statechart diagram hapus data barang**j. Statechart diagram hapus data pelanggan**

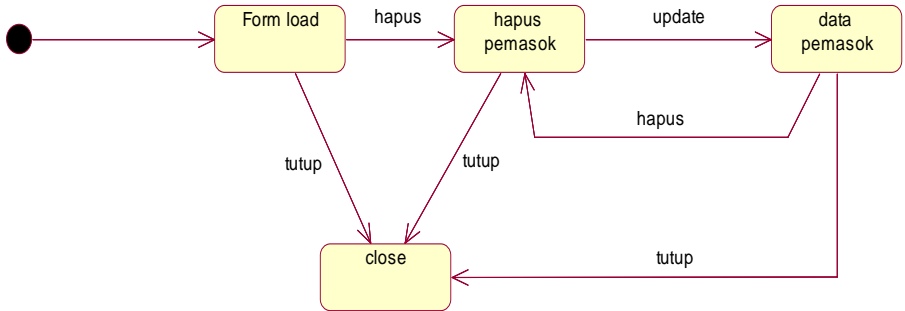
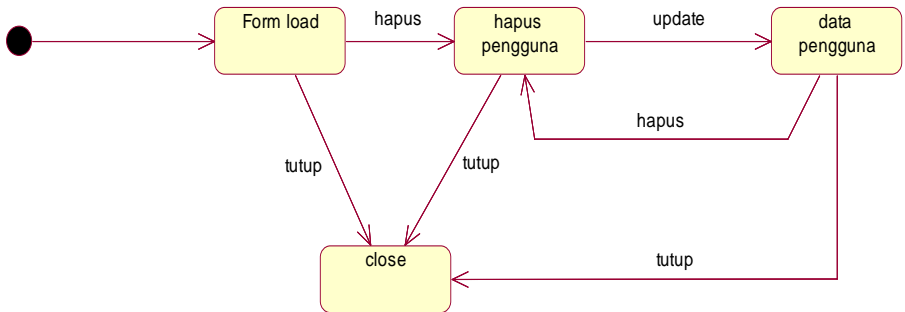
k. Statechart diagram hapus data pemasok**l. Statechart diagram hapus data pengguna**

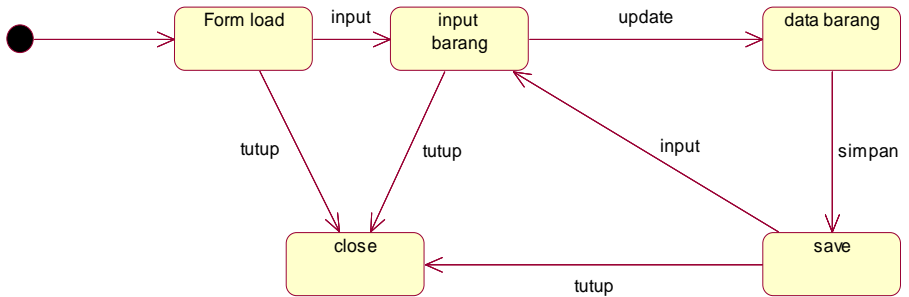
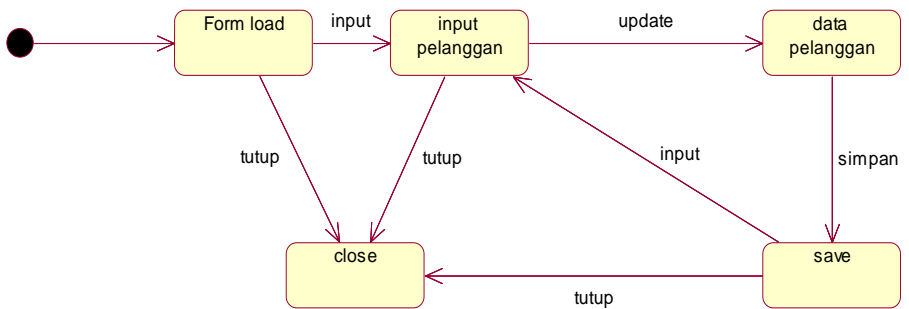
m. Statechart diagram input data barang**n. Statechart diagram input data pelanggan**

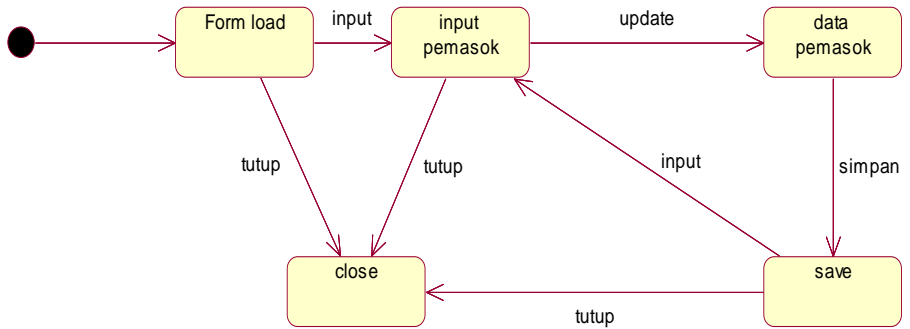
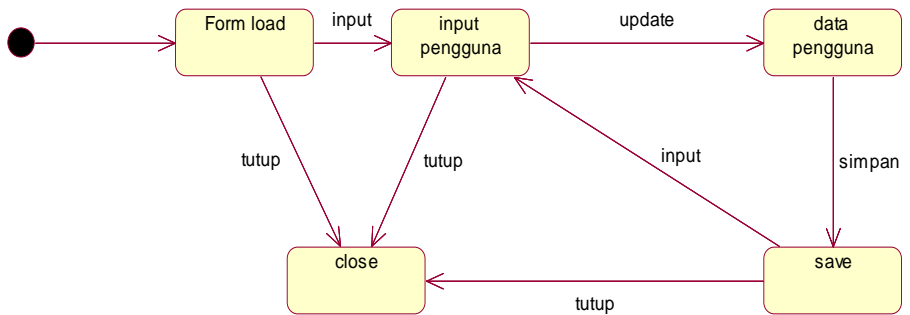
o. Statechart diagram input data pemasok**p. Statechart diagram input data pengguna**

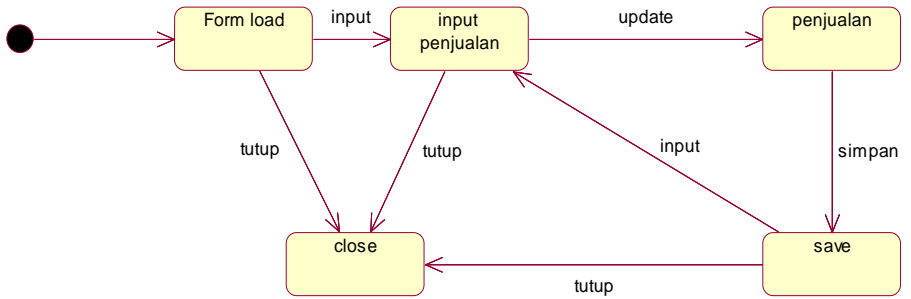
q. Statechart diagram input penjualan**r. Statechart diagram input pembelian**